



DL-ATG

ANTI-TAILGATING DETECTOR WITH DIRECTIONAL LOGIC

Designed to accurately count passenger vehicles, including tailgating vehicles, and identify their direction of travel over two small inductive loops.

FEATURES

- AB / BA Directional Counts displayed on front panel LCD
- Counts bumper to bumper passenger vehicles
- Counts accurately if a metal object is placed in the loop area
- Calibration mode automatically sets the sensitivity to the optimum level

HIGHLIGHTS

- Counts are stored in non-volatile memory
- Single lane directional counting on DLATG-1
- Two lane directional counting on DL-ATG-2
- Four relay outputs: Loop A presence, Loop B presence, AB count (pulse), BA count (pulse)



NEMA CABINET COMPATIBLE

Overview: The Model DL-ATG is a two channel, shelf mount type, inductive loop vehicle detector with separate directional AB and BA counters. Standard loop detectors stop counting vehicles when metal objects are placed in the loop area. The Model DLATG ignores extraneous metal objects placed in the loop. The Model DL-ATG has been specifically designed and tested to count and detect standard passenger vehicles. Commercial vehicles or vehicles towing trailers may not be accurately counted.

A --> B Count: When activated, the LCD screen displays the number of vehicles that have traveled over the loops in the AB direction. The counter is capable of accumulating up to 99,999 directional counts before rolling over to zero. The display will show the hundreds, tens, and ones digits until the accumulated count exceeds 999. At this point the display alternates between the ten thousands and thousands digits and the three digits for hundreds, tens, and ones. Loss of power will not reset the accumulator, which is indicated by the Δ symbol located at the bottom of the LCD screen

B --> A Count: When activated, the LCD screen displays the number of vehicles that have traveled over the loops in the BA direction. This unit is capable of accumulating up to 99,999 directional counts before rolling over to zero. The display will show the hundreds, tens, and ones digits until the accumulated count exceeds 999. At this point the display will alternate between the ten thousands and thousands digits and the three digits for hundreds, tens, and ones. Loss of power will not reset accumulator, which is indicated by the Δ symbol located at the bottom of the LCD screen.

Count Reset: Resets count accumulators to zero and LCD returns to AB Count display.

Loop Fail: When pressed, the display shows the number of past failures for each loop. Any current failure will be indicated on the LCD display.



Diagnostics: When this feature is activated the LCD continuously displays the Loop Inductance value (L) in microhenries (μH). When a vehicle is detected the LCD screen automatically changes to display the percentage of inductance change ($-\Delta\text{L}/\text{L}$ value). A single audible beep sounds for vehicles counted traveling in the AB direction. A double audible beep sounds for vehicles counted in the BA direction. After 15 minutes the diagnostic display and audible indications turn OFF and return to the AB Count display.

Operating Temperature: -40°F to $+180^{\circ}\text{F}$

Display: The LCD backlighting illuminates whenever any push-button is pressed. The backlighting extinguishes 15 minutes after the last actuation of a push-button.

Status Indicators: The detector has four LEDs to indicate A Presence, AB Count, B Presence, and BA Count.

Self-Tuning: The detector automatically tunes and is operational within two seconds after application of power or after being reset.

Environmental: The detector is fully self-compensating for environmental changes.

Loop Size and Spacing: Each detector channel is connected to a single loop having three to five turns of wire. The two loops should be the same size and number of turns. For the DL-ATG-1 recommended loop size is 3' x 6' with 8' spacing. For the DL-ATG-2 recommended loop size is 3' x 18' with 8' spacing.

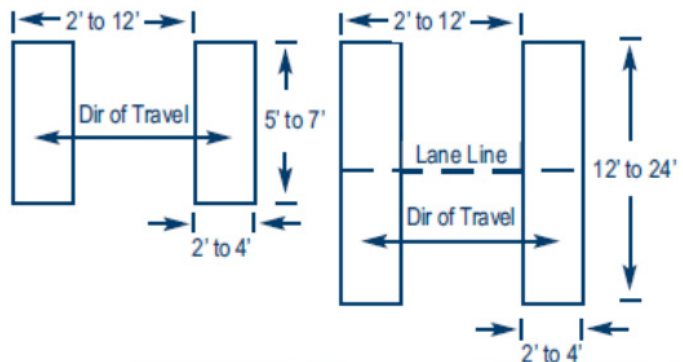

Grounded Loop Operation: The loop isolation transformer allows operation with poor quality loops, which may include a single point short to ground.

Feeder Cable Length: Up to 1000 feet. If cable length is longer than 200 feet, use 5 turns in the loop.

Loop Fail Monitor: If a loop fails, the LED for the failed channel will flash 3 times per second and the LCD will display LOOP FAIL. If the loop self-heals, the detector will resume normal operation. However, the flashing LED loop fail indication continues until the detector is reset. To view the total number of loop failures, press the Loop Fail button.

Power: 89 to 135 VAC, 50/60 Hz, 6 Watts maximum.

Loop Inductance: 40 to 500 microhenries.

Lightning Protection: Meets and/or exceeds NEMA TS 1-1989 specifications for transient voltage protection.

Relay Rating: The relay contacts are rated for 3 Amps maximum, 150 VDC maximum, and 180 Watts maximum switched power.

Weight: 29.5 oz

Size: 6.45 inches high x 2.50 inches wide x 6.35 inches deep (excluding connector). Connector adds 0.675 inch to depth measurement.

Circuit Board: Printed circuit boards are 0.062 inch thick FR4 material with 2 oz. copper on both sides and plated through holes. Circuit boards and components are conformal coated with polyurethane.

Connector: MS 3102A-22-14P (See Pin Assignments table.).

Pin Assignments:

Pin	Function
A	Power, Neutral, 120 VAC
B	BA Count, Relay Common
C	Power Line, 120 VAC
D	Channel A Loop Input
E	Channel A Loop Input
F	Channel B Loop Input
G	Channel B Loop Input
H	Chassis Ground
J	No Connection
K	No Connection
L	No Connection
M	No Connection
N	Channel A Presence, Relay Normally Open
P	Channel A Presence, Relay Common
R	AB Count, Relay Common
S	AB Count, Relay Normally Open
T	Channel B Presence, Relay Common
U	Channel B Presence, Relay Normally Open
V	BA Count, Relay Normally Open

Specifications subject to local environmental conditions, and may be subject to change. All Eberle Design LLC. products are Designed, Manufactured and Tested in the United States of America in facilities that are certified to ISO quality standards. "Eberle Design Inc." and Eberle Design LLC. logo are trademarks of Eberle Design Inc. © 2024, Eberle Design LLC. Document: EDI_DATA_DL-ATG_RevA