

# CMUip-2212

## ATCC Cabinet Monitor Unit Operations Manual

THIS MANUAL CONTAINS TECHNICAL INFORMATION FOR  
THE **CMUip-2212-HV**, **CMUip-2212-LV**, and **CMUip-2212-VHV**  
ATC CABINET MONITOR UNIT.

Firmware Version 2.2 (vXX22) Issue J, K PCBs

REVISION: JUNE 2023  
pn 888-2212-001



### - NOTE -

EDI ECCOM SOFTWARE MUST BE UPDATED TO VERSION 4.5 OR HIGHER.  
EDI MONITORKEY SOFTWARE MUST BE UPDATED TO VERSION 2.6 OR HIGHER.

EDI SOFTWARE IS AVAILABLE AT [WWW.EDITRAFFIC.COM](http://WWW.EDITRAFFIC.COM)

EBERLE DESIGN INC.

3510 East Atlanta Avenue  
Phoenix, AZ 85040 USA  
[www.EDITraffic.com](http://www.EDITraffic.com)

Tel (480) 968-6407  
Fax (602) 437-1996



THE CMUp-2212 SERIES CABINET MONITOR UNIT IS DESIGNED AND  
MANUFACTURED IN THE USA BY  
EBERLE DESIGN INC.  
PHOENIX, ARIZONA.

EDI IS CERTIFIED TO ISO 9001:2015 QUALITY SYSTEMS STANDARDS.

IPACK AND LEDguard ARE REGISTERED TRADEMARKS OF EDI. DATAKEY AND  
KEYCEPTICLE ARE TRADEMARKS OF DATAKEY INC. INFORMATION CONTAINED  
HEREIN IS PROPRIETARY TECHNICAL INFORMATION OF EBERLE DESIGN INC.  
PUBLICATION, REPRODUCTION OR USE IN WHOLE OR PART IS NOT PERMITTED  
EXCEPT UNDER TERMS AGREED UPON IN WRITING.

© COPYRIGHT 2020 EDI

U.S. Pat. No. 7,246,037  
Canadian Patent No. 2,574,101  
U.S. Pat. No. 9,460,620  
US Pat. No. 10,262,531

**MAINTENANCE NOTE**

**THIS CABINET MONITOR UNIT HAS BEEN CAREFULLY INSPECTED AND  
TESTED TO ENSURE PROPER OPERATION. IT IS RECOMMENDED THAT  
THE CABINET MONITOR UNIT BE TESTED AT LEAST ANNUALLY TO  
ENSURE PROPER OPERATION AND COMPLIANCE WITH FACTORY  
SPECIFICATIONS.**

# Table of Contents

<b>Section 1 GENERAL</b> .....	<b>1</b>
1.1 Overview.....	1
1.2 Channel Configuration.....	1
1.3 High Density Switch Pack (HDSP).....	1
1.4 High Density Flasher Unit (HDFU).....	2
1.5 CMUip-2212 Programming.....	2
1.6 Detailed CMU Status.....	2
1.6.1 ECcom Software Interface.....	2
1.6.2 Auxiliary Display Unit.....	2
1.7 Serial Bus #1.....	3
1.7.1 Serial Bus #1 Message Types.....	3
1.8 Serial Bus #3.....	3
1.8.1 Serial Bus #3 Message Types.....	3
1.9 Failed State Action (LFSA, LFSA-R, NFSA).....	4
1.9.1 Exit From FSA.....	4
<b>Section 2 MONITOR FUNCTIONS</b> .....	<b>5</b>
2.1 Cabinet Power Supply Monitor.....	5
2.2 Conflicting Channels Monitor.....	5
2.3 Serial Bus Monitor.....	5
2.3.1 Serial Bus #1 Error.....	5
2.3.2 Serial Bus #3 Error.....	5
2.4 Type 62 FSA Message.....	6
2.5 Lack of Signal Inputs Monitor.....	6
2.6 Multiple Input Monitor.....	6
2.7 Yellow Clearance Monitor.....	6
2.8 Yellow Plus Red Clearance Monitor.....	7
2.9 Local Flash Status.....	7
2.9.1 Local Flash Status Recovery.....	7
2.10 Circuit Breaker Trip Status.....	7
2.11 Flasher Unit Output Failed Alarm.....	7
2.12 CMU Power Failure.....	8
2.12.1 Mains Voltage Level Sense.....	8
2.12.2 Power Interrupt.....	8
2.12.3 Power Recovery.....	8
2.12.4 Power Up.....	8
2.12.5 Minimum Flash Interval.....	8
2.13 Field Output Check.....	8
2.13.1 Field Check Mode.....	9
2.13.2 Field Check Status.....	9
2.14 Diagnostic Error.....	9
2.14.1 Ram Memory Diagnostic.....	9
2.14.2 Nonvolatile Memory Diagnostic.....	9
2.14.3 Datakey Memory Diagnostic.....	9
2.14.4 Internal MPU Monitor.....	10
2.15 Recurrent Pulse Detection.....	10
2.15.1 Recurrent Pulse Detection Disable.....	10
2.16 Flashing Yellow Arrow (FYA) Protected-Permissive Monitoring.....	11
2.16.1 FYA Configuration.....	11
2.16.1.1 Protected Turn Channel.....	11
2.16.1.2 Permissive Turn Channel.....	11
2.16.1.3 Opposing Through Channel.....	11
2.16.2 Configuring the CMUip-2212 Fault Parameters For FYA.....	11

2.16.2.1 Conflict .....	12
2.16.2.2 Red Fail .....	12
2.16.2.3 Dual Indication .....	12
2.16.2.4 Minimum Yellow Clearance.....	13
2.16.2.5 Yellow Plus Red Clearance.....	13
2.16.3 Red and Yellow Input Enable .....	13
2.16.4 Flash Rate Detection.....	13
2.16.5 FYA Yellow Trap Conflict Detection.....	13
<b>Section 3 INPUT SIGNALS .....</b>	<b>15</b>
3.1 <i>LEDguard</i> <sup>®</sup> Field Signal Sensing .....	15
3.2 Load Switch Current.....	15
3.3 PDA Control Signal Inputs .....	15
3.3.1 Local Flash Status .....	15
3.3.2 Main Contactor (MC) Coil Status .....	15
3.3.3 Main Contactor (MC) Secondary Status .....	15
3.3.4 FTR Coil Drive Status .....	16
3.3.5 Circuit Breaker (CB) Trip Status .....	16
3.3.6 Front / Rear Door Switch.....	16
3.4 Monitor Interlock.....	16
3.5 External Test Reset input .....	16
3.6 Serial Bus #1 Address Inputs .....	16
3.7 Serial Bus #1 Disable input .....	17
3.8 CMUip-2212 Temperature.....	17
<b>Section 4 FRONT PANEL DESCRIPTION .....</b>	<b>18</b>
4.1 Indicators .....	18
4.1.1 Power Indicator .....	18
4.1.2 48VDC FAIL Indicator .....	18
4.1.3 24VDC FAIL Indicator .....	18
4.1.4 12VDC FAIL Indicator .....	18
4.1.5 CONFLICT Indicator .....	18
4.1.6 LACK OF SIGNAL Indicator.....	18
4.1.7 MULTIPLE Indicator.....	18
4.1.8 CU Indicator.....	18
4.1.9 LOCAL FLASH Indicator .....	18
4.1.10 CLEARANCE Indicator .....	19
4.1.11 FIELD CHECK Indicator.....	19
4.1.12 SB #1 ERROR Indicator.....	19
4.1.13 SB #3 ERROR Indicator.....	19
4.1.14 DIAGNOSTIC Indicator .....	19
4.1.15 SB #1 RX Indicator.....	19
4.1.16 SB #3 RX Indicator.....	19
4.2 Reset Button .....	19
4.3 Datakey.....	19
<b>Section 5 SPECIFICATIONS.....</b>	<b>21</b>
5.1 Electrical .....	21
5.1.1 CMU-2212-HV .....	21
5.1.2 CMU-2212-LV .....	22
5.1.3 CMU-2212-VHV .....	22
5.2 Timing .....	23
5.3 Mechanical.....	24
5.4 Environmental .....	24
<b>Section 6 CONNECTOR ASSIGNMENTS.....</b>	<b>25</b>
6.1 Main DIN Connector.....	25

6.1.1 CMUip-2212-HV & CMUip-2212-VHV Pin List.....	25
6.1.2 CMUip-2212-LV Pin List.....	25
6.2 CMUip-2212 Ethernet LAN Port .....	26
6.2.1 Ethernet LAN Cable .....	26

## Section 1 GENERAL

### 1.1 OVERVIEW

The model CMUip-2212 Cabinet Monitor Unit (CMUip-2212) is the principle part of the ATC Traffic Control Cabinet Monitoring System. It is resident in the Output Assembly and communicates with the High Density Switch Packs (HDSP) located in each Output Assembly via Serial Bus #3. The role of the CMUip-2212 is to query various cabinet conditions and, if the application requires action, the CMUip-2212 will transfer control from the Advanced Traffic Controller (ATC) to a flashing control mode. Applications include the detection of, and response to, improper and conflicting signals and improper operating voltages in a cabinet assembly caused by malfunctions of the (ATC), load switches, or miss wiring of the cabinet.

The communications between the ATC and the CMUip-2212 via Serial Bus #1 plays an integral role in ensuring safe and proper operation of the cabinet equipment as well as providing important diagnostic functions used for trouble shooting malfunctioning equipment.

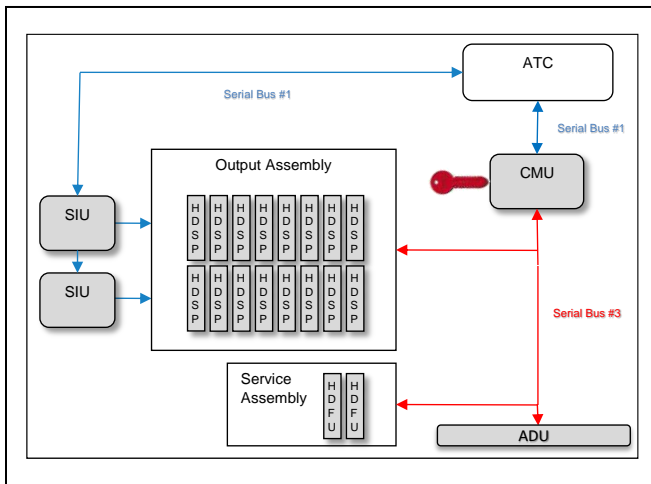

### 1.2 CHANNEL CONFIGURATION

The CMUip-2212 can be configured to monitor up to 32 physical load switch channels of three inputs per channel. Each channel is comprised of a Red / Dont Walk input, a Yellow input, and a Green / Walk input.

When populated with fourteen or less HDSPs, an additional four virtual channels can be programmed in the CMUip-2212 to provide a total of 32 logical channels.

### 1.3 HIGH DENSITY SWITCH PACK (HDSP)

The HDSP-FU (*iPack*<sup>®</sup> 2202) provides the CMUip-2212 with voltage and current measurements from each installed Output Assembly. Each HDSP has the capability to measure and report field terminal voltages and load currents for two channels of three outputs per channel. Each HDSP is configured by its Output Assembly address. For further information concerning the HDSP, see the Eberle Design *iPack*<sup>®</sup> **HDSP-FU Operations Manual** (pn 888-2202-001).

- WARNING -

The ATC must verify that all channels being driven by a Serial Interface Unit (SIU) are being monitored by an enabled HDSP, and that each HDSP is enabled by the programming in the CMU datakey.

Failure to provide this check may result in unmonitored load switch outputs. This could occur as a result of improper configuration of the cabinet, improper address assignment for one or more HDSP units, improper address assignment for one or more SIU units, or improper programming of the ATC.

## 1.4 HIGH DENSITY FLASHER UNIT (HDFU)

The HDSP-FU (*iPack*<sup>®</sup> 2202) provides the CMUip-2212 with voltage and current measurements from each installed HDFU flasher unit. Each HDFU has the capability to measure and report field terminal voltages and load currents for two channels of two outputs per channel. The HDFU is configured by its Output Assembly address. For further information concerning the HDFU, see the Eberle Design *iPack*<sup>®</sup> **HDSP-FU Operations Manual** (pn 888-2202-001).

## 1.5 CMUIP-2212 PROGRAMMING

The CMUip-2212 is individually configured using a removable nonvolatile memory device called a Datakey<sup>™</sup> (Datakey is a registered trademark of Datakey Electronics, Inc.). The Datakey replaces the mechanical jumper or diode based program card used in conventional signal monitors and provides an electronic method of programming the CMU-2212. The Datakey contains a nonvolatile prom device that is read by the CMU-2212. The Datakey itself is programmed by a separate programming device using a Personal Computer program such as the Eberle Design MonitorKey product. See the Eberle Design **MonitorKey Operations Manual** (pn 888-1212-001) for further details.

## 1.6 DETAILED CMU STATUS

### 1.6.1 ECCOM SOFTWARE INTERFACE

The front panel display of the CMUip-2212 provides limited operational status. Detailed status is obtained through the front panel Ethernet port (CMUip-2212) using Eberle Design *ECcom* Signal Monitor Communications software running on a personal computer. The *ECcom* software provides access to real time monitor data such as current field signal status, field terminal voltages, cabinet control voltages, channel load current status, temperature, and fault status. Historical event logs and signal sequence logs are also provided. See the **EDI ECcom Operation Manual** (pn 888-1000-001) for further details. The *ECcom* Signal Monitor Communications software can be obtained from the Eberle Design web site at [www.EDIttraffic.com](http://www.EDIttraffic.com).

### 1.6.2 AUXILIARY DISPLAY UNIT

The Eberle Design *Auxiliary Display Unit* (ADU) is a display module that provides an enhanced user interface and SmartMonitor<sup>®</sup> technology for the ATCC Cabinet Monitor Unit (CMU-2212) system. The *Auxiliary Display Unit* is intended to mount into a 1U space of the 19 inch rack of an ITS Cabinet. The ADU communicates with the CMUip-2212 via Serial Bus #3. See the **ADU Operation Manual** (pn 888-0217-001) for details.

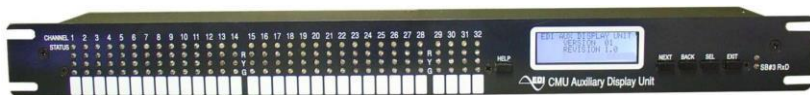

## 1.7 SERIAL BUS #1

Serial Bus #1 provides a communication path between the CMUp-2212 to the ATC. The communications between the ATC and the CMUp-2212 plays an integral role in ensuring safe and proper operation of the cabinet equipment as well as providing important diagnostic functions used for trouble shooting malfunctioning equipment. Standardized communications can be broken into three categories; real time and latched fault status, configuration verification, and malfunction detection and diagnosis.

Messages are defined that allow the ATC and the CMUp-2212 to perform redundant checks on each other. The ATC has access to all CMUp-2212 information including field signal input status, permissive programming, and fault status. This gives the ATC the capability to provide a backup monitoring function and make enhanced event logging, remote intersection monitoring, and remote diagnostics feasible. Similarly, the CMUp-2212 receives information from the ATC that corresponds to the output commands to the load switches. This data allows the CMUp-2212 to better respond to and diagnose fault situations.

### 1.7.1 SERIAL BUS #1 MESSAGE TYPES

The CMUp-2212 is compatible with the following message types:

- Type 60 Module Identification Command / Type 188 Module Identification Response
- Type 80 Module Description Command / Type 208 Module Description Response
- Type 81 Load Switch Drivers Command / Type 209 CMU Status Response
- Type 62 Set FSA Command / Type 190 FSA Response
- Type 82 Get CMU Configuration Command / Type 210 CMU Configuration Response
- Type 66 Time and Date Broadcast Command
- Type 67 Load Switch Drivers Command / Type 195 CMU Short Status Response

## 1.8 SERIAL BUS #3

Serial Bus #3 is used to transfer data from a maximum of sixteen HDSP units and two High Density Flasher Units (HDFU) to the CMU-2212. The CMUp-2212 will poll each HDSP for its voltage and load current data every 32 milliseconds. The CMUp-2212 then maps the retrieved data to the proper logical channel and evaluates the state of the field signals for fault conditions.

### 1.8.1 SERIAL BUS #3 MESSAGE TYPES

The CMUp-2212 is compatible with the following message types:

- Type 1 HDSP Status Command / Type 129 Status Response
- Type 2 HDFU Status Command / Type 130 HDFU Response
- Type 60 Module ID Command / Type 188 Module ID Response
- Type 128 Negative Acknowledge Response



## **1.9 FAILED STATE ACTION (LFSA, LFSA-R, NFSA)**

When triggered by the detection of a fault condition that exists longer than the minimum defined period, the CMUip-2212 will enter the Failed State Action (fault) mode causing the OUTPUT relay to de-energize and the contacts on the OUTPUT NO pins to open. The cabinet assembly should be wired such that the opening of the OUTPUT NO relay contacts will cause an automatic switching of the field signal outputs from normal operation to flashing operation.

Only Unit Reset from the Reset Button or EXTERNAL RESET TEST input will reset the CMUip-2212 from a LATCHED FAILED STATE ACTION (LFSA). Only a Unit Reset from the Reset Button or EXTERNAL RESET TEST input or a CMUip-2212 Power Fail will reset a LATCHED RESETTABLE FAILED STATE ACTION (LFSA-R).

A NONLATCHED FAILED STATE ACTION (NFSA) will be reset if the fault conditions causing the NFSA have been removed. An NFSA will last for the programmed Minimum Flash time at a minimum.

Only one LFSA, LFSA-R or NFSA fault state will be set at any time.

### **1.9.1 EXIT FROM FSA**

Prior to the CMUip-2212 transferring the OUTPUT NO contacts from the FSA state to the No Fault state, a transition period of 500 milliseconds will occur. During the transition period the OUTPUT NO contacts will be in the FSA state and the CMUip-2212 will set the Start-Up Flash Call bit in the Type 209 (195) Frame to 1. At all other times the Start-Up Flash Call bit of the Type 209 (195) Frame will be set to 0. This provides an early indication to the ATC that exit from the FSA state is occurring and the start-up phases should be set.

## Section 2 MONITOR FUNCTIONS

### 2.1 CABINET POWER SUPPLY MONITOR

The CMUip-2212 will sense the Cabinet +48VDC, +24VDC and +12VDC power supply sources. The CMUip-2212 will also sense the Cabinet +24VDC state as reported by each HDSP. Voltages less than the threshold voltages for the Fault time or longer (section 5.1.3) will cause a LFSA. A +48VDC, +24VDC failure or +12VDC failure during the programmed Minimum Flash time or during a CMUip-2212 Power Failure will not cause a LFSA. The CMUip-2212 will report the value of the +24 VDC and +12 VDC power supply sources in the Type 209 response frame.

There is programming in the Datakey to disable +12 VDC and 48VDC power supply monitoring.

### 2.2 CONFLICTING CHANNELS MONITOR

For purpose of conflict determination, an active signal on either of the Green/Walk or Yellow inputs associated with any of the 32 channels will be considered as that channel being active. The Datakey will contain the permissive channel pair programming.

When any conflicting channels are detected as concurrently active for less than the No Fault time (section 5.1.3) the CMUip-2212 will not cause a LFSA. When any conflicting channels are detected as concurrently active for the Fault time or longer (section 5.1.3), the CMUip-2212 will cause a LFSA. For all other timing in between, the CMUip-2212 may or may not cause a LFSA.

### 2.3 SERIAL BUS MONITOR

The CMUip-2212 communicates with both Serial Bus (SB) #1 and #3. In SB #1 the CMUip-2212 is a Secondary device, polled by the ATC Primary device. On SB #1, the CMUip-2212 will respond to the Serial Bus #1 Address defined by the ADDRESS 0 and ADDRESS 1 pins. On SB #3 the CMUip-2212 is the Primary device, polling each HDSP or HDFU Secondary device.

#### 2.3.1 SERIAL BUS #1 ERROR

The CMUip-2212 will cause a FSA when a Type 81 or Type 67 Frame has not been received from the ATC for greater than the Fault time (section 5.1.3). The first and second failures in a 24-hour period will be a NFSA. The third failure in a 24-hour period will be a LFSA-R. If a CMUip-2212 Power Fail resets the LFSA-R, the SB #1 failure count will be reset to two, such that the next SB #1 timeout results in a LFSA-R.

A SB #1 timeout failure during the programmed Minimum Flash time or during a CMUip-2212 Power Failure will not cause a FSA. The SB #1 Timeout function will be disabled if the SB #1 DISABLE input is at a True (Low) state

#### 2.3.2 SERIAL BUS #3 ERROR

The CMUip-2212 will cause a FSA when a Type 129 or Type 130 Frame has not been received from each enabled HDSP for greater than the Fault time (section 5.1.3). The first and second failures in a 24-hour period will be a NFSA. The third failure in a 24-hour period will be a LFSA-R. If a CMUip-2212 Power Fail resets the LFSA-R, the SB #3 timeout count will be reset to two, such that the next SB #3 timeout results in a LFSA-R.

A SB #3 timeout failure during the programmed Minimum Flash time or during a CMUip-2212 Power Failure will not cause a FSA.

## 2.4 TYPE 62 FSA MESSAGE

If the "N" bit is set in a Type 62 message, the CMUip-2212 will react by causing a NFSA. The NFSA will remain until the receipt of a Message 62 with the "N" bit cleared or until the CMUip-2212 is reset by a Unit Reset or CMUip-2212 Power Fail. The NFSA will last for the programmed Minimum Flash time at a minimum.

If the "L" bit is set in a Type 62 message, the CMUip-2212 will react by causing a LFSA.

## 2.5 LACK OF SIGNAL INPUTS MONITOR

The CMUip-2212 will detect the absence of a required signal voltage on all the inputs of a channel OR the absence of any required output load current. For voltage purposes a required signal on the Green OR Yellow OR Red inputs associated with a channel will be considered as that channel being Voltage Active. For load current purposes an output load current above the programmed threshold for an output will be considered as that output being Current Active. When a channel is not Voltage Active OR Current Active for less than the No Fault time (section 5.1.3), the CMUip-2212 will not cause a LFSA. When a channel is not Voltage Active OR Current Active for greater than the Fault time (section 5.1.3), the CMUip-2212 will cause a LFSA.

If Virtual channels are used, then the Current Sense Unit (CSU) monitor function is hardwired to the source outputs, before they are remapped. The CSU monitor function should be programmed at the virtual channel positions (channels 29-32) and not the source channel positions. An HDSP must not be installed into Output Assembly slots 15 and 16 when Virtual channels are used.

Lack of Signal Input monitoring will be disabled for all channels when the MC COIL STATUS input is not active. There is programming in the Datakey to disable Lack of Signal Input monitoring on a per output basis.

Lack of Signal Input monitoring will also be disabled for any channel which has the DARK CHANNEL MAP bit set to "1" in the Datakey programming for the DARK CHANNEL MAP addressed by the DARK CHANNEL MAP SELECT bits in a Type 81 (67) message.

## 2.6 MULTIPLE INPUT MONITOR

The CMUip-2212 will detect the presence of an active signal on two or more inputs of a channel. When the presence of an active signal on two or more inputs of a channel is detected for less than the No Fault time (section 5.1.3), the CMUip-2212 will not cause a LFSA. When the presence of an active signal on two or more inputs to a channel is detected for the Fault time (section 5.1.3) or longer, the CMUip-2212 will cause a LFSA.

Multiple Input monitoring will be disabled when the MC COIL STATUS input is not active. There is programming in the Datakey to disable Multiple Indication monitoring on a color combination basis (G+Y, Y+R, G+R) for each channel.

## 2.7 YELLOW CLEARANCE MONITOR

The CMUip-2212 will verify that the Yellow Change interval is at least 2.7 +/-0.1 seconds. The Yellow Change interval consists of the duration of time in which the Yellow field signal input is active in a sequence from Green to Yellow to Red. When the minimum Yellow Change interval is not satisfied, the CMUip-2212 will cause a LFSA. The CMUip-2212 will report a Skipped Yellow Clearance when the Yellow Change interval is less than 100 milliseconds. The CMUip-2212 will report a Short Yellow Clearance when the Yellow Change interval is less than 2.7 +/- 0.1 seconds and greater than 100 milliseconds.

Minimum Yellow Change interval monitoring will be disabled when the MC COIL STATUS input is not active. There is programming in the Datakey to disable Minimum Yellow Change interval monitoring on a per channel basis.

## **2.8 YELLOW PLUS RED CLEARANCE MONITOR**

The CMUip-2212 will verify that the Yellow Change plus Red Clearance interval between the end of an active Green/Walk signal and the beginning of the next conflicting Green/Walk signal is at least 2.7 +/-0.1 seconds. When the minimum Yellow Change plus Red Clearance interval is not satisfied, the CMUip-2212 will cause a LFSA.

Minimum Yellow Change plus Red Clearance monitoring will be disabled when the MC COIL STATUS input is not active. There is programming in the Datakey to disable Minimum Yellow Change plus Red Clearance interval monitoring on a per channel basis.

## **2.9 LOCAL FLASH STATUS**

The CMUip-2212 will monitor the LF STATUS input. This input is used to indicate to the CMUip-2212 that the cabinet should be placed into NFSA as a result of the AUTO/FLASH switch being transferred to the FLASH position. When this signal is sensed as not active for greater than the Fault time (section 5.1.3), the CMUip-2212 will cause a NFSA. When this signal is sensed as not active for less than the No Fault time (section 5.1.3) the CMUip-2212 will not cause a NFSA.

During Local Flash Status mode, the Auxiliary Display Unit (ADU) will display the active field signals. This can be helpful to verify that flash mode is active on all outputs appropriately. Note that a short time delay will be introduced to the ADU display in this mode.

### **2.9.1 LOCAL FLASH STATUS RECOVERY**

Recovery from Local Flash Status NFSA will occur when this signal is sensed as active for greater than the Fault time (section 5.1.3).

## **2.10 CIRCUIT BREAKER TRIP STATUS**

The CMUip-2212 will monitor the CB TRIP STATUS input. When one or more circuit breakers have tripped this input will go to the not-active state. When this signal is sensed as not active for greater than the Fault time (section 5.1.3) the CMUip-2212 will cause a LFSA. When this signal is sensed as not active for less than the No Fault time (section 5.1.3) the CMUip-2212 will not cause a LFSA.

## **2.11 FLASHER UNIT OUTPUT FAILED ALARM**

The CMUip-2212 will monitor the FLASHER 1-1, FLASHER 1-2, FLASHER 2-1, FLASHER 2-2 voltage states reported by each HDFU. A second HDFU (#2) may be installed as an option and must be enabled in the configuration parameters. A failed state may indicate a malfunction of the connector system or flash voltage bus or HDFU unit.

When a transition from the inactive state to the active state or a transition from the active state to the inactive state is absent for greater than the Active time (section 5.1.3), the CMUip-2212 will set a status bit in the Type 209 (195) frame. This alarm condition will not cause a FSA. It should cause the appropriate response in the ATC. This status is non-latching such that once a status bit has been set, the sensing of five valid transitions of the input will clear the status bit.

## **2.12 CMU POWER FAILURE**

The CMUip-2212 will monitor the MAINS input and the NRESET and POWERDOWN cabinet control inputs to determine a CMU Power Failure response. The POWERDOWN signal in the False (low) state indicates loss of Mains voltage in the ATC. A CMU Power Failure will be recognized when both the POWERDOWN and NRESET signals are False (low) for greater than 100 ms or the MAINS voltage is below the dropout level.

The 24VDC Monitor function (section 2.1) will be disabled while the POWERDOWN signal is in the False state. The 24VDC FAIL indicator will flash at a 2Hz rate (section 4.1.2).

### **2.12.1 MAINS VOLTAGE LEVEL SENSE**

The CMUip-2212 will monitor the MAINS input and the LV+ or HV+ SIGNAL inputs reported by each HDSP. When the CMUip-2212 MAINS voltage is less than the Dropout voltage (section 5.1) for greater than Mains Level Sense timing (section 5.1.3) the CMUip-2212 will cause a NFSA. Once NFSA has been set, the POWERDOWN and NRESET signals will not be monitored until all Mains voltages have exceeded the Mains Restore voltage (section 5.1).

#### **2.12.2 POWER INTERRUPT**

The CMUip-2212 will disable monitoring of the +12VDC and +24VDC power supply inputs when either the POWERDOWN or NRESET input is False (low). When the POWERDOWN and NRESET signals are both False (low) the CMUip-2212 will cause a NFSA.

#### **2.12.3 POWER RECOVERY**

When the POWERDOWN input is True (high) and the NRESET signal goes from False (low) to True (high) the CMUip-2212 will begin timing the programmed Minimum Flash Interval. During the Minimum Flash Interval the CMUip-2212 will be in NFSA.

#### **2.12.4 POWER UP**

Following initial application of MAINS voltage the CMUip-2212 will maintain a NFSA until the POWERDOWN input is True (high) and the NRESET signal goes from False (low) to True (high). The CMUip-2212 will then begin timing the programmed Minimum Flash Interval. During the Minimum Flash Interval the CMU will be in NFSA.

#### **2.12.5 MINIMUM FLASH INTERVAL**

During the Minimum Flash Interval the CMUip-2212 will be in NFSA. The Minimum Flash Interval will be programmed in the Datakey between the limits of 6 seconds to 16 seconds with an incremental adjustment of 1 second. The CMUip-2212 will not set a FSA during the Minimum Flash Interval.

## **2.13 FIELD OUTPUT CHECK**

The Field Output Check is a continuous verification that the field signal output states set by the ATC are properly driven to the signal loads and correctly sensed by the HDSP and CMU-2212. It is an enhanced function made possible by the Serial Bus #1 communications between the ATC and CMU-2212. The CMUip-2212 will receive a Type 81 (67) message from the ATC that contains an image of the controller output commands to the load switches. When a fault condition triggers the CMU-2212, the Type 81 (67) message information received while the fault condition was being timed will be used by the CMUip-2212 to determine whether the sensed field signal input status corresponded to the ATC output commands. This diagnostic information may then be used to isolate whether the fault condition was caused by an ATC malfunction or a failure in the load switch and/or field wiring.

The Field Output Check function is enabled for each channel input individually and provides two modes of operation, Field Check Mode and Field Check Status.

### **2.13.1 FIELD CHECK MODE**

The CMUip-2212 will compare the active states of the field signals with the states reported by the ATC in the Type 81 (67) frame. When a mismatch is detected for less than the No Fault time (section 5.1.3) the CMUip-2212 will not cause a LFSA. When a mismatch is detected for greater than the Fault time (section 5.1.3), the CMUip-2212 will cause a LFSA.

The Field Check Mode is typically caused by a miss-wired or improperly configured cabinet. When the Field Check Mode is detected the FIELD CHECK front panel indicator will be illuminated solid.

Field Output Check monitoring will be disabled when the MC COIL STATUS input is not active. There is programming in the Datakey to disable Field Output Check monitoring on a channel input basis.

### **2.13.2 FIELD CHECK STATUS**

The CMUip-2212 will compare the active states of the field signals with the states reported by the CU in the Type 81 (67) frame. When a mismatch is detected while a Conflict, Lack of Signal, or Multiple fault is timing, Field Check Status will be reported with the fault to indicate the faulty channel(s) and color(s).

If a Conflict, Lack of Signal, or Multiple fault has triggered the CMUip-2212 to the fault mode and the CMUip-2212 indicates that there is no Field Check Status, the ATC or ATC programming is the most likely cause. The lack of Field Check Status indicates the ATC drove the signals to an improper state. If a Conflict, Lack of Signal, or Multiple fault has triggered the CMUip-2212 to the fault mode and the CMUip-2212 indicates that there is Field Check Status, then cause of the malfunction can be isolated to the SIU, load switch, field wiring, or signal load.

When Field Check Status is detected the FIELD CHECK front panel indicator will be flash at a 2Hz rate.

Field Output Check monitoring will be disabled when the MC COIL STATUS input is not active. There is programming in the Datakey to disable Field Output Check monitoring on a channel input basis.

## **2.14 DIAGNOSTIC ERROR**

The CMUip-2212 is provided with a resident series of self-check diagnostic capabilities. When a Diagnostic fault is detected, a LFSA-R will be set and the DIAGNOSTIC indicator illuminated. Should a Diagnostic error occur, other fault indicators that may be concurrently displayed with the DIAGNOSTIC indicator may not be valid due to the nature of these hardware and/or firmware failures.

### **2.14.1 RAM MEMORY DIAGNOSTIC**

This test will verify that all RAM elements are operating correctly at power-up or following a Unit Reset.

### **2.14.2 NONVOLATILE MEMORY DIAGNOSTIC**

This test will verify that the nonvolatile flash ROM and event log eeprom contain the proper data. The routine will perform a check on each ROM device and make a comparison with a check value.

### **2.14.3 DATAKEY MEMORY DIAGNOSTIC**

This test will verify whether the non-volatile Datakey contains valid data. The routine will perform a check on each nonvolatile memory element at power-up and whenever read and make a comparison with a 16 bit Frame Check Sequence (FCS) procedure defined in clause

4.6.2 of ISO/IEC 3309. Invalid data may result from corrupted Datakey contents, an invalid FCS calculation, invalid parameter values, or a Datakey Protocol Version incompatibility.

The Datakey not present will cause a LFSA and illuminate the DIAGNOSTIC indicator if the DOOR SWITCH FRONT input is sensed as not active (door closed). The DIAGNOSTIC indicator will flash at a rate of 2Hz if the Datakey is not present when the DOOR SWITCH FRONT input is sensed as active (door open).

#### 2.14.4 INTERNAL MPU MONITOR

The CMUip-2212 will monitor the operation of its microprocessor with an independent circuit. At a minimum, the monitoring circuit will receive logic state transitions at least once every 50 milliseconds from the microprocessor. When the logic state transition is not received for 500 milliseconds the monitor circuit will force a LFSA-R and illuminate the DIAGNOSTIC indicator.

#### 2.15 RECURRENT PULSE DETECTION

This error detection function supplements the normal Conflict, Multiple, and Lack of Signal monitoring algorithms for sensing faults that are intermittent or pulsing in nature. The RMS signal detection algorithm is designed to filter out short term transients commonly found on the electrical service and provide noise immunity against false signal detections. The Recurrent Pulse detection function is designed to respond to fault conditions that are intermittent in nature and do not meet the continuous timing requirements of the normal detection algorithms, yet may still produce improper signal displays. These input conditions are differentiated by their longer time constant and fault response times.

The figure below shows a simple example of a recurrent Conflict fault. Channel 2 Green is detected active due to a malfunction of the load switch that caused the output to flicker. On for 100 ms approximately every 200 ms. Because normal Conflict detection requires a continuous fault of at least 350 ms duration, this event could go undetected. The Recurrent Pulse detection algorithm will combine these pulses into one event and trigger a Conflict fault once the longer recurrent timing threshold is exceeded.

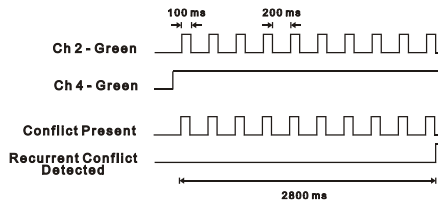

When triggered by a recurrent fault condition, the Signal Monitor will enter the fault mode, transfer the Output relay contacts to the Fault position, and illuminate the appropriate CONFLICT, MULTIPLE, or LACK OF SIGNAL indicator. The unit will remain in the fault mode until reset by the Reset button or the External Reset input. Fault response times will vary depending on the pulse width and frequency of the recurrent inputs, but will range from 1000 ms minimum to 10.4 seconds maximum. Recurrent Pulse detection can be disabled with the SEL1 option jumper, see Section 2.15.1.

##### 2.15.1 RECURRENT PULSE DETECTION DISABLE

The Recurrent Pulse Detection function can be disabled by soldering a 0-ohm jumper into position SEL1 on the CMUip-2212 printed circuit board. When the jumper is inserted, Recurrent Pulse Detection is disabled. When the jumper is removed, Recurrent Pulse Detection is enabled.

## 2.16 FLASHING YELLOW ARROW (FYA) PROTECTED-PERMISSIVE MONITORING

The CMUip-2212 is designed to monitor an intersection with up to eight approaches using the four section Flashing Yellow Arrow (FYA) movement outlined by the NCHRP Research Project 3-54 on Protected/Permissive signal displays with Flashing Yellow Arrows, and complies with all requirements of **NEMA Standard TS-2 Amendment 4-2012 Flashing Yellow Arrow**.

### - NOTE -

The ATCC standard CMUip-2212 is defined to support six FYA approaches. The CMUip-2212 firmware release vXX20 or higher must be installed in the CMU to provide support for eight FYA approaches. ECom and MonitorKey software must be updated to v4.5+ and v2.6+ respectively. Consult the EDI factory for further details.

For monitoring purposes an FYA approach is logically defined as a four input "logical channel" consisting of the solid Red Arrow, solid Yellow Arrow, flashing Yellow Arrow (permissive), and solid Green Arrow (protected). A Flashing Yellow Arrow approach is typically monitored using two load switches and two physical channels of the CMU-2212.

### 2.16.1 FYA CONFIGURATION

The following three clauses define the nomenclature used in this Section 2.16.1, as described in **NEMA Standard TS2-2016 Flashing Yellow Arrow**.

#### 2.16.1.1 PROTECTED TURN CHANNEL

The Protected Turn Channel of the FYA channel pair is composed of the solid Green arrow (Ga) indication of the FYA Signal Output Group.



#### 2.16.1.2 PERMISSIVE TURN CHANNEL

The Permissive Turn Channel of the FYA channel pair is composed of the solid Red arrow (Ra), solid Yellow arrow (Ya), and the flashing Yellow arrow (fYa) indications of the FYA Signal Output Group. The flashing Yellow arrow (fYa) indication will be displayed as the Green input of the Permissive Turn Channel.



#### 2.16.1.3 OPPOSING THROUGH CHANNEL

An Opposing Through channel is also associated with the FYA channel pair. The Opposing Through channel is the channel that conflicts with the FYA Protected Turn Channel and is permissive with the Permissive Turn Channel (flashing Yellow arrow).

### 2.16.2 CONFIGURING THE CMUIP-2212 FAULT PARAMETERS FOR FYA

The CMUip-2212 built-in Setup Wizard in the *MonitorKey* software will automatically configure the fault configuration parameters for Red Fail, Dual Indication, Field Check, and Minimum Y+R Clearance. **The Flashing Yellow Arrow configuration settings should be applied before running the MonitorKey Setup Wizard.** The MonitorKey form for setting the FYA parameters is shown below:



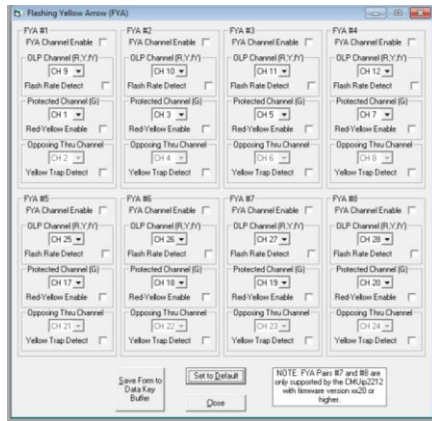

For an FYA channel pair the fault configuration parameters are applied to the **Primary** channel with three inputs, Ra-Ya-fYa. The fault configuration parameters programmed for the **Sparse** channel of the FYA pair with only one input, Ga, only affects the sparse channel and not the Primary channel, and should be used only when the RY INPUT Enable option is Enabled for that channel.

### 2.16.2.1 CONFLICT

The CMUp-2212 will verify that no conflicting channels to the solid Yellow arrow channel (clearance) are active as determined by the Program Card compatibility programming of the solid Yellow arrow channel of the pair except during the following sequences:

#### 2.16.2.1.1 PROTECTED YELLOW CHANGE INTERVAL CONFLICT

During the Yellow change interval of the Protected Turn channel (Green arrow), the CMUp-2212 will verify that no conflicting channels to the solid Yellow arrow channel (clearance) are active as determined by the Permissive compatibility programming of the Protected Turn channel (Green arrow) of the pair.

#### 2.16.2.1.2 PERMISSIVE YELLOW CHANGE INTERVAL CONFLICT

During the Yellow change interval of the Permissive Turn channel (flashing Yellow arrow), the CMUp-2212 will verify that no conflicting channels to the solid Yellow arrow channel (clearance) are active as determined by the Permissive compatibility programming of the Permissive Turn channel (flashing Yellow arrow).

### 2.16.2.2 RED FAIL

A Red Fail fault will occur if the solid Red Arrow AND solid Yellow Arrow AND flashing Yellow Arrow AND solid Green Arrow all remain inactive for the Red Fail fault response time. The fault status will be displayed for both channels of the FYA channel pair.

If the Red Fail function is enabled and the RY Input option is Enabled for the sparse channel (Ga), then a Red Fail fault will occur if the Red AND Yellow AND Green all remain inactive on the sparse channel for the Red Fail fault response time. The fault status will be displayed for the sparse channel of the FYA pair.

### 2.16.2.3 DUAL INDICATION

A Dual Indication fault will occur if any two or more of the solid Red Arrow, solid Yellow Arrow, flashing Yellow Arrow, or solid Green Arrow signal combinations are active simultaneously

for the Dual Indication fault response time. The fault status will be displayed for both channels of the FYA pair when the sparse channel input (Ga) is active.

If the RG, RY, or GY Dual Indication function is enabled and the RY Input option is enabled for the sparse channel (Ga), then a Dual Indication fault will occur if any two or more of the Red, Yellow, or Green inputs are active simultaneously on the sparse channel for the Dual Indication fault response time. The fault status will be displayed for the sparse channel of the FYA pair.

#### **2.16.2.4 MINIMUM YELLOW CLEARANCE**

A Yellow Clearance fault will be detected if the channel pair sequences from the protected Green Arrow to the solid Red Arrow without a minimum clearance time on the solid Yellow Arrow. The fault status will be displayed for the solid Yellow Arrow channel.

A Yellow Clearance fault will be detected if the channel pair sequences from the permissive flashing Yellow Arrow to the solid Red Arrow without a minimum clearance time on the solid Yellow Arrow. The fault status will be displayed for the solid Yellow Arrow channel.

If the Minimum Yellow Clearance function is enabled and the RY Input option is enabled for the sparse channel (Ga), a Yellow Clearance fault will be detected if the sparse channel sequences from the Green input to the solid Red input without a minimum clearance time on the Yellow input. The fault status will be displayed for the sparse channel (Ga).

#### **2.16.2.5 YELLOW PLUS RED CLEARANCE**

The Minimum Yellow Plus Red Clearance function is not designed to operate with Flashing Yellow Arrows. This function must be Disabled for the FYA channels that provide the Permissive flashing Yellow arrow. This allows the CU to sequence from the Permissive Left turn channel directly to the Protected Left Turn channel without a solid Yellow arrow clearance interval.

#### **2.16.3 RED AND YELLOW INPUT ENABLE**

The Red and Yellow outputs of the sparse channel of an FYA channel pair are typically not loaded with a signal head and thus left floating. In these cases the Red and Yellow inputs for the sparse FYA channels can be forced to the Off state in the CMUip-2212 by default. This simplifies the cabinet wiring such that the use of dummy cabinet loads or modifications to the Output harness are not necessary.

If the Red and Yellow outputs of the sparse channel of an FYA channel pair are driving signal loads (such as a hard wired right turn overlap) then they must be monitored by the CMUip-2212 at all times. The RY INPUT option should then be enabled for that channel. The fault configuration parameters programmed for this Sparse channel of the FYA pair only affects the Sparse channel and not the Primary channel, and should be enabled only when the RY INPUT option is Enabled for that channel.

#### **2.16.4 FLASH RATE DETECTION**

When the FLASH RATE FAULT option is enabled, the CMUip-2212 will monitor a flashing yellow arrow output for a lack of flashing operation. If any of the enabled flashing yellow arrow signals remain active for more than the FYA Flash Rate Fault time (Section 5.1.3), the CMUip-2212 will enter the fault mode, transfer the OUTPUT relay contacts to the Fault position, and display the FYA FLASH-RATE FAIL status screen. The CMUip-2212 will remain in the fault mode until the unit is reset by the RESET button.

#### **2.16.5 FYA YELLOW TRAP CONFLICT DETECTION**

When the FYA TRAP DETECT option is enabled, the CMUip-2212 will monitor each FYA permissive turn channel for the FYA Yellow Trap condition. The FYA Yellow Trap conflict condition occurs when the Permissive Turn channel (flashing yellow arrow) sequences to the

solid yellow arrow clearance while the Opposing Through channel is still showing a green ball.

When the FYA Yellow Trap Conflict condition is detected, the CMUip-2212 will enter the fault mode, transfer the OUTPUT relay contacts to the Fault position, and display the "CONFtrap" fault status screen. The CMUip-2212 will remain in the fault mode until the unit is reset by the RESET button.

## Section 3 INPUT SIGNALS

### 3.1 LEDGUARD® FIELD SIGNAL SENSING

The CMUip-2212 uses a technique called *LEDguard*® that is designed to better monitor the characteristics of LED based signal loads. Each field signal input is measured and compared to both a high threshold and a low threshold value to determine On / Off status. This differs from conventional standard NEMA operation where the active threshold is picked according to the color of the field signal. Once the high and low On / Off thresholds (Section 5.1) have been determined using the input RMS voltage, the individual fault monitor functions use the appropriate threshold to determine if a fault condition exists.

<b>LEDguard®</b>	<b>Green/Walk</b>	<b>Yellow</b>	<b>Red/Dont Walk</b>
<b>Conflict</b>	Low	Low	---
<b>Lack of Signal</b>	High	High	High
<b>Dual Indication</b>	Low	Low	Low
<b>Clearance</b>	Low	Low	High

### 3.2 LOAD SWITCH CURRENT

Load current is sensed by the HDSP based on total load current to all colors of a channel. Total load current is an indication that a signal load is present. Lack of adequate load current indicates no active load (i.e. burned out lamps) or an open field wire condition. Load current monitoring is used by the Lack of Signal monitoring function (see 2.5) to detect the loss of signal load while the load switch is in the On state.

A channel will be sensed active when the load current exceeds the programmed Channel LOS Current Sense Threshold programmed for that channel in the Datakey. A channel will not be sensed active when the load current is less than the Channel LOS Current Sense Threshold programmed for that channel in the Datakey. A hysteresis value of +/- 2 mA is used for load currents less than 120 mA. A hysteresis value of +/- 16 mA is used for load currents greater than 120 mA.

The Channel Current Sense Threshold should be programmed for each monitored channel based on the minimum signal load under all worst case conditions.

### 3.3 PDA CONTROL SIGNAL INPUTS

#### 3.3.1 LOCAL FLASH STATUS

The cabinet should be wired such that operation of the cabinet in AUTO mode will place an active voltage on the LF STATUS pin (see Section 5.1). Operation of the cabinet in FLASH mode should be open circuit on this input. The CMUip-2212 will report the state of this input in the Type 209 (195) frame. See section 2.9.

#### 3.3.2 MAIN CONTACTOR (MC) COIL STATUS

The cabinet should be wired such that the MC COIL STATUS input is connected to the control side of the main contactor signal bus relay coil. An active signal (see Section 5.1) on this input indicates the Signal Bus should be powering the load switches. The CMUip-2212 will report the state of this input in the Type 209 (195) frame.

#### 3.3.3 MAIN CONTACTOR (MC) SECONDARY STATUS

The cabinet should be wired such that the MC SECONDARY STATUS input will be connected to the output side of the main contactor signal bus relay. An active signal (see

Section 5.1) on this input indicates the Signal Bus is powering the load switches. The CMUip-2212 will report the state of this input in the Type 209 (195) frame.

### 3.3.4 FTR COIL DRIVE STATUS

The cabinet should be wired such that the FTR COIL DRIVE STATUS input is connected to the FTR COIL DRIVE signal in the SIGNAL POWER BUS. An active signal on this input (see Section 5.1) indicates the flash transfer relays are energized and the field signals are driven from the load switch outputs. The CMUip-2212 will report the state of this input in the Type 209 (195) frame.

### 3.3.5 CIRCUIT BREAKER (CB) TRIP STATUS

The cabinet should be wired such that the CB TRIP STATUS input will be connected to the Auxiliary Switch output of the circuit breaker unit. The active state of this input (see Section 5.1) indicates that the circuit breaker unit is not in the tripped state. The CMUip-2212 will report the state of this input in the Type 209 (195) frame.

### 3.3.6 FRONT / REAR DOOR SWITCH

The cabinet should be wired such that voltage is applied to the DOOR SWITCH FRONT or DOOR SWITCH REAR inputs when the respective door is Open. These inputs will be considered active (see Section 5.1) when the door is open. These inputs will not be considered active when the door is closed. The CMUip-2212 will report the state of these inputs in the Type 209 (195) frame.

The Datakey not present will cause a LFSA if the DOOR SWITCH FRONT input is sensed as not active (door closed). See section 2.14.3.

## 3.4 MONITOR INTERLOCK

The MONITOR INTERLOCK input is connected to VDC GROUND within the CMU-2212. The cabinet should be wired such that the lack of VDC GROUND on this pin forces the cabinet to the flash mode. This prevents a cabinet from operating without a CMUip-2212 installed.

## 3.5 EXTERNAL TEST RESET INPUT

The EXTERNAL TEST RESET input is used to reset the CMUip-2212 from the FSA condition. When the EXTERNAL TEST RESET input is connected to VDC GROUND (True) all front panel indicators will be illuminated for 100 msec and the OUTPUT relay energized. Continuously activating the input will not affect CMUip-2212 operation.

The EXTERNAL TEST RESET input is intended for use in testing the CMUip-2212 and should not be connected in the cabinet.

## 3.6 SERIAL BUS #1 ADDRESS INPUTS

The Address Select input pins ADDRESS 0 and ADDRESS 1 define the Serial Bus #1 address of the CMU. The pins are left open for a logical False, and are connected to VDC GROUND for a logical True.

ADDRESS 1	ADDRESS 0	SB #1 ADDRESS
False	False	0x0F
False	True	0x10
True	False	0x11
True	True	0x12

The default address for the CMU is 0x0F. If multiple CMU units are not installed on Serial Bus #1 these inputs should be left in the False (open) state.

### **3.7 SERIAL BUS #1 DISABLE INPUT**

The SERIAL BUS #1 DISABLE input is used to prevent a Serial Bus #1 Error when communications from the ATC is not active. When the SERIAL BUS #1 DISABLE input is connected to VDC GROUND (True) The CMUip-2212 will not communicate on Serial Bus #1 or set a FSA condition if communications from the ATC is not present. See section 2.3.1.

The SERIAL BUS #1 DISABLE input is intended for use in testing the CMUip-2212 and should not be connected in the cabinet.

### **3.8 CMUIP-2212 TEMPERATURE**

The CMUip-2212 will measure the ambient temperature and report this value in the Type 209 frame. This temperature indication may be used to analyze malfunctions that could be related to over heating or cold conditions.

## **Section 4**

### **FRONT PANEL DESCRIPTION**

#### **4.1 INDICATORS**

##### **4.1.1 POWER INDICATOR**

A green POWER indicator will illuminate to indicate MAINS voltage is proper. It will flash at a 2 Hz rate when the MAINS input of the CMU is less than the Dropout voltage (see Section 5.1). It will remain Off when the MAINS voltage is less than approximately 60% of nominal MAINS voltage.

##### **4.1.2 48VDC FAIL INDICATOR**

A red 48VDC FAIL indicator will illuminate when the CMUip-2212 is in FSA as a result of a 48VDC cabinet power supply fault.

The 48VDC FAIL indicator will pulse at a 2 Hz rate when the 48VDC monitor function is disabled. The 48VDC, 24VDC FAIL and 12VDC FAIL will pulse when either the POWERDOWN or NRESET input is False (low). See section 2.12.2.

##### **4.1.3 24VDC FAIL INDICATOR**

A red 24VDC FAIL indicator will illuminate when the CMUip-2212 is in FSA as a result of a 24VDC cabinet power supply fault.

The 24VDC FAIL indicator will pulse at a 2 Hz rate when the 24VDC monitor function is disabled. The 48VDC, 24VDC FAIL and 12VDC FAIL will pulse when either the POWERDOWN or NRESET input is False (low). See section 2.12.2.

##### **4.1.4 12VDC FAIL INDICATOR**

A red 12VDC FAIL indicator will illuminate when the CMUip-2212 is in FSA as a result of a 12VDC cabinet power supply fault.

##### **4.1.5 CONFLICT INDICATOR**

A red CONFLICT indicator will illuminate when the CMUip-2212 is in FSA as a result of a Conflicting Channels fault. See section 2.2. The CONFLICT indicator will flash at 2Hz when a Flash Rate Fail fault has been detected on a FYA channel. See section 2.16.4.

##### **4.1.6 LACK OF SIGNAL INDICATOR**

A red LACK OF SIGNAL indicator will illuminate when the CMUip-2212 is in FSA as a result of a Lack of Signal Inputs fault. See section 2.5.

##### **4.1.7 MULTIPLE INDICATOR**

A red MULTIPLE indicator will illuminate when the CMUip-2212 is in FSA as a result of a Multiple Inputs fault. See section 2.6.

##### **4.1.8 CU INDICATOR**

A red CU indicator will illuminate when the CMUip-2212 is in FSA as a result of a Type 62 command from the ATC (see section 2.4).

##### **4.1.9 LOCAL FLASH INDICATOR**

A red LOCAL FLASH indicator will illuminate when the CMUip-2212 is in FSA as a result of the LOCAL FLASH STATUS input is inactive (see section 2.9), or CB TRIP STATUS is inactive (see section 2.10).

During Local Flash Status mode, the Auxiliary Display Unit (ADU) will display the active field signals. This can be helpful to verify that flash mode is active on all outputs appropriately. Note that a short time delay will be introduced to the ADU display in this mode.

#### **4.1.10 CLEARANCE INDICATOR**

A red CLEARANCE indicator will illuminate when the CMUip-2212 is in FSA as a result of a Yellow Clearance or Yellow Plus Red Clearance fault. See section 2.7 and 2.8.

#### **4.1.11 FIELD CHECK INDICATOR**

A red FIELD CHECK indicator will illuminate when the CMUip-2212 is in FSA as a result of a Field Check Mode fault. The indicator will flash at a 2Hz rate when the CMUip-2212 is in FSA with Field Check Status as a result of Conflict, Lack of Signal, or Multiple fault. See section 2.13.

#### **4.1.12 SB #1 ERROR INDICATOR**

A red SB #1 ERROR indicator will illuminate when the CMUip-2212 is in FSA as a result of a Serial Bus #1 fault. See section 2.3.1. The SB #1 ERROR indicator will pulse at a 2 Hz rate when the SERIAL BUS #1 DISABLE input is True. See section 3.7.

#### **4.1.13 SB #3 ERROR INDICATOR**

A red SB #3 ERROR indicator will illuminate when the CMUip-2212 is in FSA as a result of a Serial Bus #3 fault. See section 2.3.2.

#### **4.1.14 DIAGNOSTIC INDICATOR**

A red DIAGNOSTIC indicator will illuminate when the CMUip-2212 is in FSA as a result of a Diagnostic fault. See section 2.14.

The DIAGNOSTIC indicator will flash at a 4 Hz rate if the Datakey is not present and a FSA state does not exist. See section 2.14.3.

#### **4.1.15 SB #1 RX INDICATOR**

A yellow SB #1 RX indicator will pulse On each time the CMUip-2212 correctly receives a frame on Serial Bus #1.

#### **4.1.16 SB #3 RX INDICATOR**

A yellow SB #3 RX indicator will pulse On each time the CMUip-2212 correctly receives a frame on Serial Bus #3.

### **4.2 RESET BUTTON**

Depressing the RESET button resets the CMUip-2212 from the FSA condition after it has been triggered by a fault. When the RESET button is depressed all front panel indicators will be illuminated for 500 msec and the OUTPUT relay energized. Continuously depressing the Reset button will not affect CMUip-2212 operation.

### **4.3 DATAKEY**

The front panel mounted Keycepticle™ is used to receive the Datakey™ serial memory device. To install a Datakey, insert the key and rotate clockwise 90 degrees to the vertical orientation. When a Datakey is installed while the power is applied to the CMU-2212, the CMUip-2212 will load and verify the parameters and begin using the new configuration immediately.

The Datakey can be removed without the CMUip-2212 placing the cabinet into flash only if the Front Door is Open.



When a Datakey is removed while the power is applied to the CMUip-2212, the CMUip-2212 will continue to use the parameters from the removed Datakey until Reset is applied, a new Datakey is installed, or a power-up cycle occurs. If a CMUip-2212 is Reset or powered-up with the Front Door in the open position without a Datakey installed or with an invalid Datakey, the CMUip-2212 will assume a default Datakey configuration according to the Datakey Protocol Version.

## Section 5 SPECIFICATIONS

### 5.1 ELECTRICAL

#### 5.1.1 CMU-2212-HV

##### Power Requirements

Operating Line Voltage.....	75 to 135 Vac
Operating Line Frequency.....	60 ± 3 Hz
Power Consumption.....	10 Watts Maximum

##### AC Field Signals

LEDguard Field Signal High Levels	
Active.....	greater than 70 Vrms
Not Active.....	less than 50 Vrms
LEDguard Field Signal Low Levels	
Active.....	greater than 25 Vrms
Not Active.....	less than 15 Vrms

##### AC Control Monitors

MC Secondary Status	
Active.....	greater than 83 Vrms
Not Active.....	less than 77 Vrms

##### DC Control Monitors

Local Flash Status, MC Coil Status, FTR Coil Drive, CB Trip Status	
Active.....	greater than 44 Vdc
Not Active.....	less than 42 Vdc
Front / Rear Door Switch	
Active.....	greater than 13 Vdc
Not Active.....	less than 11 Vdc

##### Mains Power Fail Monitor

HV+ Mains Restore.....	greater than 87 ± 2 Vrms
HV+ Mains Dropout.....	less than 82 ± 2 Vrms

##### DC Voltage Monitors

+48 Volt Monitor	
Active.....	greater than 46 Vdc
Not Active.....	less than 44 Vdc
+24 Volt Monitor	
Active.....	greater than 22 Vdc
Not Active.....	less than 18 Vdc
+12 Volt Monitor	
Active.....	greater than 11 Vdc
Not Active.....	less than 9 Vdc

##### Logic Inputs

External Test Reset, Serial Bus #1 Disable, Address 0, Address 1	
Not Active (False).....	greater than 16 Vdc
Active (True).....	less than 8 Vdc

##### CMU Temperature

Accuracy.....	± 6 °C
---------------	--------

### 5.1.2 CMU-2212-LV

#### Power Requirements

Operating Mains Voltage .....	35 to 60 Vdc
Operating Mains Nominal Voltage .....	48 Vdc
Power Consumption .....	10 Watts Maximum

#### DC Field Signals

LEDguard Field Signal High Levels	
Active .....	greater than 43 Vrms
Not Active .....	less than 41 Vrms
LEDguard Field Signal Low Levels	
Active .....	greater than 8 Vrms
Not Active .....	less than 6 Vrms

#### DC Control Monitors

Local Flash Status, MC Coil Status, FTR Coil Drive, CB Trip Status	
Active .....	greater than 44 Vdc
Not Active .....	less than 42 Vdc
Front / Rear Door Switch	
Active .....	greater than 13 Vdc
Not Active .....	less than 11 Vdc

#### Power Fail Monitor

Mains Restore .....	greater than 45 ± 1 Vrms
Mains Dropout .....	less than 43 ± 1 Vrms

#### DC Voltage Monitors

+48 Volt Monitor	
Active .....	greater than 46 Vdc
Not Active .....	less than 44 Vdc
+24 Volt Monitor	
Active .....	greater than 22 Vdc
Not Active .....	less than 18 Vdc
+12 Volt Monitor	
Active .....	greater than 11 Vdc
Not Active .....	less than 9 Vdc

#### Logic Inputs

External Test Reset, Serial Bus #1 Disable, Address 0, Address 1	
Not Active (False) .....	greater than 16 Vdc
Active (True) .....	less than 8 Vdc

#### CMU Temperature

Accuracy .....	± 6 °C
----------------	--------

### 5.1.3 CMU-2212-VHV

#### Power Requirements

Operating Line Voltage .....	150 to 270 Vac
Operating Line Frequency .....	47 to 63 Hz
Power Consumption .....	10 Watts Maximum

#### AC Field Signals

LEDguard Field Signal High Levels	
Active .....	greater than 140 Vrms
Not Active .....	less than 100 Vrms
LEDguard Field Signal Low Levels	
Active .....	greater than 50 Vrms

Not Active ..... less than 30 Vrms

**AC Control Monitors**

MC Secondary Status

Active ..... greater than 166 Vrms

Not Active ..... less than 154 Vrms

**DC Control Monitors**

Local Flash Status, MC Coil Status, FTR Coil Drive, CB Trip Status

Active ..... greater than 44 Vdc

Not Active ..... less than 42 Vdc

Front / Rear Door Switch

Active ..... greater than 13 Vdc

Not Active ..... less than 11 Vdc

**Mains Power Fail Monitor**

HV+ Mains Restore ..... greater than  $174 \pm 2$  Vrms

HV+ Mains Dropout ..... less than  $164 \pm 2$  Vrms

**DC Voltage Monitors**

+24 Volt Monitor

Active ..... greater than 22 Vdc

Not Active ..... less than 18 Vdc

+12 Volt Monitor

Active ..... greater than 11 Vdc

Not Active ..... less than 9 Vdc

**Logic Inputs**

External Test Reset, Serial Bus #1 Disable, Address 0, Address 1

Not Active (False) ..... greater than 16 Vdc

Active (True) ..... less than 8 Vdc

**CMU Temperature**

Accuracy .....  $\pm 6$  °C

**5.2 TIMING**

Cabinet Power Supplies

Fault ..... greater than 500 ms

No Fault ..... less than 200 ms

Typical ..... 400 ms

Conflict

Fault ..... greater than 500 ms

No Fault ..... less than 200 ms

Typical ..... 350 ms

Serial Bus #1 Error

Fault ..... greater than 600 ms

Serial Bus #3 Error

Fault ..... greater than 300 ms

Multiple

Fault ..... greater than 450 ms

No Fault ..... less than 200 ms

Typical ..... 400 ms

Lack of Signal Inputs

Fault ..... greater than 1500 ms  
No Fault ..... less than 1200 ms  
Typical ..... 1350 ms

Yellow Clearance

Fault ..... less than 2600 ms  
No Fault ..... greater than 2800 ms  
Typical ..... 2700 ms

Yellow Plus Red Clearance

Fault ..... less than 2600 ms  
No Fault ..... greater than 2800 ms  
Typical ..... 2700 ms

Field Check

Fault ..... greater than 1600 ms  
No Fault ..... less than 1400 ms  
Typical ..... 1500 ms

Local Flash Status

Fault ..... greater than 350 ms  
No Fault ..... less than 200 ms  
Typical ..... 300 ms

Circuit Breaker Trip

Fault ..... greater than 400 ms  
No Fault ..... less than 200 ms  
Typical ..... 350 ms

AC Line Level Sense

Fault ..... greater than 750 ms  
No Fault ..... less than 550 ms  
Typical ..... 650 ms

Flasher (HDFU) Alarm

Active ..... greater than 2500 ms

NRESET, POWERDOWN

Active ..... greater than 120 ms  
Not Active ..... less than 80 ms  
Typical ..... 100 ms

FYA Flash Rate

No Fault ..... less than 1300 msec  
Fault ..... greater than 1500 msec  
Typical ..... 1450 msec

**5.3 MECHANICAL**

Height ..... 4.166 ± 0.05 inches  
Width ..... 1.650 ± 0.05 inches  
Depth (front panel to rear edge of DIN connector) ..... 7.717 ± 0.1 inches

**5.4 ENVIRONMENTAL**

Storage Temperature Range ..... -45 to +85 °C  
Operating Temperature Range ..... -34 to +74 °C  
Humidity (non-condensing) ..... 0 to 95% Relative

## Section 6 CONNECTOR ASSIGNMENTS

### 6.1 MAIN DIN CONNECTOR

The CMUIP-2212 main connector is a two row DIN 4161264 Header Type.

#### 6.1.1 CMUIP-2212-HV & CMUIP-2212-VHV PIN LIST

Pin #	Function	Pin #	Function
A1	+24VDC Monitor	B1	Reserved
A2	+12VDC Monitor	B2	External Test Reset
A3	VDC Ground	B3	Serial Bus #1 Disable
A4	Monitor Interlock	B4	Reserved
A5	Address 0	B5	Address 1
A6	Reserved	B6	Reserved
A7	SB1 TxData +	B7	SB1 TxData -
A8	SB1 RxData +	B8	SB1 RxData -
A9	SB1 TxClock +	B9	SB1 TxClock -
A10	SB1 RxClock +	B10	SB1 RxClock -
A11	Reserved	B11	Reserved
A12	Reserved	B12	Reserved
A13	Reserved	B13	Reserved
A14	Reserved	B14	Reserved
A15	Line Sync +	B15	Line Sync -
A16	Nreset +	B16	Nreset -
A17	PowerDown +	B17	PowerDown -
A18	SB3 TxData +	B18	SB3 TxData -
A19	SB3 RxData +	B19	SB3 RxData -
A20	SB3 Clock+	B20	SB3 Clock-
A21	LF Status	B21	LF Status
A22	Output Relay NO	B22	Output Relay NO
A23	CB Trip Status	B23	Reserved
A24	MC Coil Status	B24	Reserved
A25	MC Secondary Status	B25	Reserved
A26	FTR Coil Drive Status	B26	Reserved
A27	Door Switch Front	B27	Reserved
A28	Door Switch Rear	B28	Reserved
A29	Reserved	B29	+48VDC Monitor
A30	Reserved	B30	AC MAINS Power
A31	Equipment Ground	B31	Reserved
A32	Reserved	B32	MAINS Ground (Neutral)

Note: Output Relay NO is open during FSA (de-energized).

#### 6.1.2 CMUIP-2212-LV PIN LIST

Pin #	Function	Pin #	Function
A1	+24VDC Monitor	B1	Reserved
A2	+12VDC Monitor	B2	External Test Reset
A3	VDC Ground	B3	Serial Bus #1 Disable
A4	Monitor Interlock	B4	Reserved
A5	Address 0	B5	Address 1
A6	Reserved	B6	Reserved
A7	SB1 TxData +	B7	SB1 TxData -
A8	SB1 RxData +	B8	SB1 RxData -

Pin #	Function	Pin #	Function
<b>A9</b>	SB1 TxClock +	<b>B9</b>	SB1 TxClock -
<b>A10</b>	SB1 RxClock +	<b>B10</b>	SB1 RxClock -
<b>A11</b>	Reserved	<b>B11</b>	Reserved
<b>A12</b>	Reserved	<b>B12</b>	Reserved
<b>A13</b>	Reserved	<b>B13</b>	Reserved
<b>A14</b>	Reserved	<b>B14</b>	Reserved
<b>A15</b>	Line Sync +	<b>B15</b>	Line Sync -
<b>A16</b>	Nreset +	<b>B16</b>	Nreset -
<b>A17</b>	PowerDown +	<b>B17</b>	PowerDown -
<b>A18</b>	SB3 TxData +	<b>B18</b>	SB3 TxData -
<b>A19</b>	SB3 RxData +	<b>B19</b>	SB3 RxData -
<b>A20</b>	SB3 Clock+	<b>B20</b>	SB3 Clock-
<b>A21</b>	LF Status	<b>B21</b>	LF Status
<b>A22</b>	Output Relay NO	<b>B22</b>	Output Relay NO
<b>A23</b>	CB Trip Status	<b>B23</b>	Reserved
<b>A24</b>	MC Coil Status	<b>B24</b>	Reserved
<b>A25</b>	MC Secondary Status	<b>B25</b>	Reserved
<b>A26</b>	FTR Coil Drive Status	<b>B26</b>	Reserved
<b>A27</b>	Door Switch Front	<b>B27</b>	Reserved
<b>A28</b>	Door Switch Rear	<b>B28</b>	Reserved
<b>A29</b>	Reserved	<b>B29</b>	DC MAINS Power
<b>A30</b>	Reserved	<b>B30</b>	No Connect
<b>A31</b>	Equipment Ground	<b>B31</b>	Reserved
<b>A32</b>	Reserved	<b>B32</b>	MAINS Ground

Note: Output Relay NO is open during FSA (de-energized).

## 6.2 CMUIP-2212 ETHERNET LAN PORT

The network port parameters can be set or changed using the EDI *ECcom* software. The network port parameters can also be configured in the Datakey. See the **EDI ECcom Operation Manual** (pn 888-1000-001) and **MonitorKey Operations Manual** (pn 888-1212-001) for details.

The default network settings are:

IP Address     192.168.1.100  
Subnet Mask   255.255.255.0  
Gateway       none

### 6.2.1 ETHERNET LAN CABLE

The LAN cable required is a typical Cat-5 network cable using the 8 pin RJ-45 connector. If the connection is from the monitor to a switch or hub, a standard LAN cable is needed. If the connection is from the monitor directly to a network adaptor (PC), a cross-over or patch cable is needed.