

## VI. Voltage Comparison Charts:

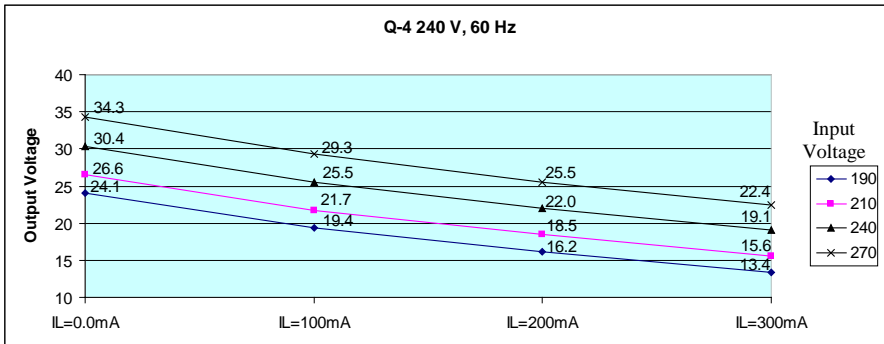
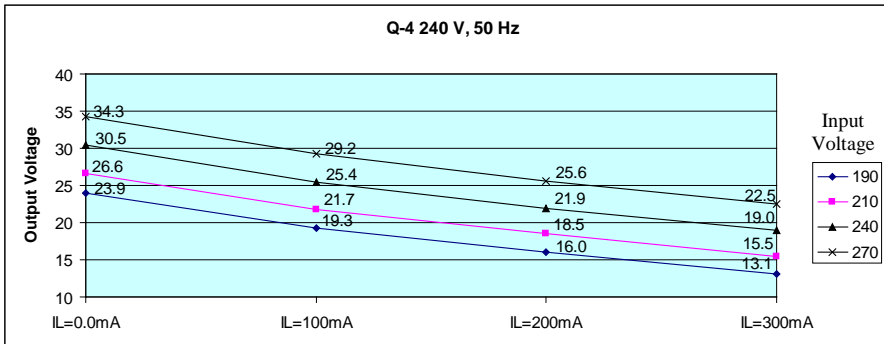
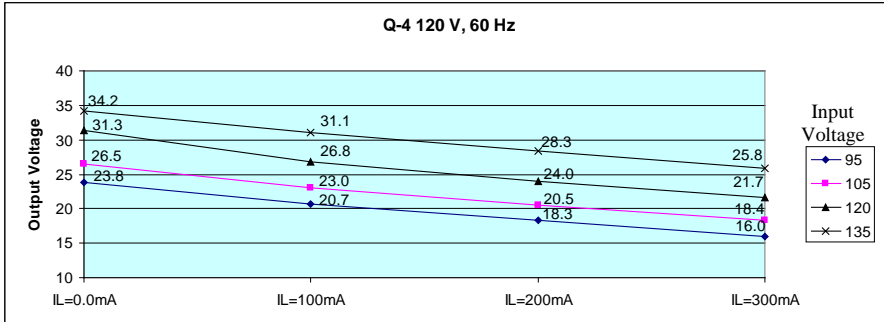
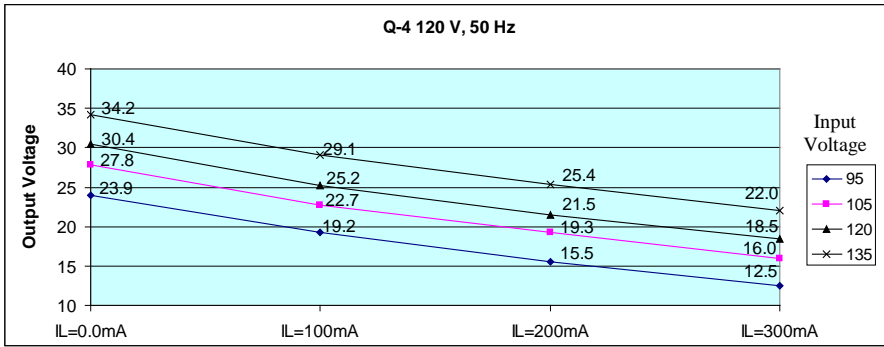

# Model Q-2, Q-4

## CARD RACK POWER SUPPLY

### OPERATING INSTRUCTIONS:

#### I. General:

The Models Q-2 and Q-4 power supplies transform 120/240 VAC, 50/60 Hz input power into unregulated 24 VDC outputs. Each output is rated for 300 mA of load current and can be paralleled (via the rack wiring) for increased current capability. The Model Q-2 has two outputs and the Model Q-4 has four outputs. The Models Q-2 and Q-4 have four configurations: 120 VAC 50 Hz, 120 VAC 60 Hz, 240 VAC 50 Hz, and 240 VAC 60 Hz. Your input voltage and frequency must match your need.



*Please verify rack wiring before applying power.*



*Turn the power switch OFF whenever removing or inserting the power supply module.*

#### II. Indicators and Controls:

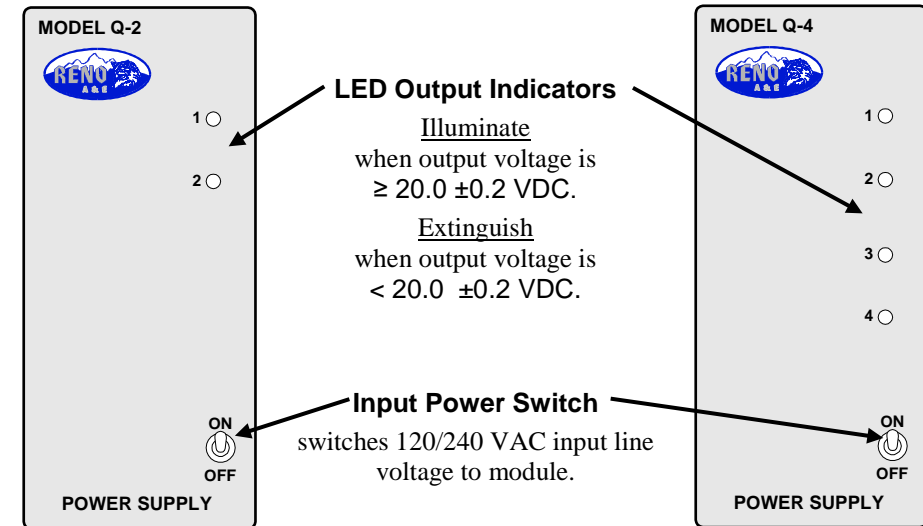

**CAUTION**  
**RISK OF ELECTRICAL SHOCK**

**ALERT:** When input power is applied, un-insulated voltages of sufficient magnitude to constitute a risk of electrical shock are present on the printed circuit board. Refer servicing to qualified service personnel.

### III. Input / Output Specifications:

Input Voltage:     **120 VAC, 50 Hz**

Output Voltage / Load Current: *(each output)*

Output Voltage	Load Current
30.4 VDC	0 mA
25.2 VDC	100 mA
21.5 VDC	200 mA
18.5 VDC	300 mA

*NOTE: Outputs may be paralleled to increase current capability*

Input Voltage:     **120 VAC, 60 Hz**

Output Voltage / Load Current: *(each output)*

Output Voltage	Load Current
31.3 VDC	0 mA
26.8 VDC	100 mA
24.0 VDC	200 mA
21.7 VDC	300 mA

*NOTE: Outputs may be paralleled to increase current capability.*

Input Voltage:     **240 VAC, 50 Hz**

Output Voltage / Load Current: *(each output)*

Output Voltage	Load Current
30.5 VDC	0 mA
25.4 VDC	100 mA
21.9 VDC	200 mA
19.0 VDC	300 mA

*NOTE: Outputs may be paralleled to increase current capability.*

Input Voltage:     **240 VAC, 60 Hz**

Output Voltage / Load Current: *(each output)*

Output Voltage	Load Current
30.4 VDC	0 mA
25.5 VDC	100 mA
22.0 VDC	200 mA
19.1 VDC	300 mA

*NOTE: Outputs may be paralleled to increase current capability.*

Fuses:                Model Q-2: **2 fuses each rated for 0.375 A**  
                              Model Q-4: **4 fuses each rated for 0.375 A**

*NOTE: The fuse holders are located near the center of the PC board.*

### IV. Detector Channel Capacity:

Model Q-2:            **Up to 8 detector channels**

Model Q-4:            **Up to 16 detector channels**

### V. Connector / Pin Assignments:

Connector:           2 x 22 pin edge card connector with 0.156 inch (0.396 cm) contact centers.  
                              The connector is centered on the 4.50 inch (11.43 cm) side of the PC board.

Pin Assignments:

Pin	Model Q-2	Model Q-4
<b>1 / A</b>	DC Common	DC Common
<b>2 / B</b>	Output #1 (+24 VDC)	Output #1 (+24 VDC)
<b>3 / C</b>	Output #2 (+24 VDC)	Output #2 (+24 VDC)
<b>10 / L</b>	Chassis Ground	Chassis Ground
<b>11 / M</b>	AC Neutral	AC Neutral
<b>12 / N</b>	AC Line	AC Line
<b>17 / U</b>	No Connection	Output #3 (+24 VDC)
<b>18 / V</b>	No Connection	Output #4 (+24 VDC)

*NOTE: All pins not listed have no connection.*