

***iPack*[®] Series**

Model 2202

High Density Switch Pack - Flasher Unit Operations Manual

THIS MANUAL CONTAINS TECHNICAL INFORMATION FOR
THE *iPack*[®] 2202 SERIES HDSP-FU.

REVISION: July 2018
pn 888-2202-001



EBERLE DESIGN INC.

3510 East Atlanta Avenue
Phoenix, AZ 85040 USA
www.EDITraffic.com

Tel (480) 968-6407
Fax (602) 437-1996



THE *iPack*[®] 2202 SERIES HIGH DENSITY SWITCH PACK – FLASHER UNIT IS
DESIGNED AND MANUFACTURED IN THE USA BY
EBERLE DESIGN INC., PHOENIX, ARIZONA

EDI IS CERTIFIED TO ISO 9001:2015 QUALITY SYSTEMS STANDARDS.

IPACK IS A REGISTERED TRADEMARK OF EBERLE DESIGN INC. INFORMATION
CONTAINED HEREIN IS PROPRIETARY TECHNICAL INFORMATION OF EBERLE
DESIGN INC. PUBLICATION, REPRODUCTION OR USE IN WHOLE OR PART IS NOT
PERMITTED EXCEPT UNDER TERMS AGREED UPON IN WRITING.

© COPYRIGHT 2018 EDI

Table of Contents

Section 1 GENERAL	1
1.1 Overview	1
1.2 Channel Configuration	1
1.3 HDSP Addressing	2
1.4 HDFU Addressing	2
Section 2 HDSP FUNCTIONS	4
2.1 Voltage Sensing	4
2.1.1 Field Signal Sensing	4
2.1.2 Flasher Input Sensing	4
2.1.3 Signal Power Sensing	4
2.2 Output Current Sensing	4
2.3 +24VDC Monitor Sensing	4
2.4 HDSP Output Override	4
2.5 Diagnostic Error	4
2.6 Serial Bus #3	5
2.6.1 Electrical	5
2.6.2 Frame Types	5
Section 3 FRONT PANEL DESCRIPTION	6
3.1 Indicators	6
3.1.1 Power Indicator	6
3.1.2 SB #3 Rx & TX Indicator	6
3.1.3 Diagnostic Indicator	6
3.1.4 ID / Flasher Indicator	6
3.1.5 ID Indicator	6
3.1.6 Flasher 1,2 Indicators	6
3.1.7 Channel Input Indicators	6
3.2 Reset Button	6
3.2.1 SB #3 Address Assignment Report	6
Section 4 SPECIFICATIONS	7
4.1 Electrical	7
4.2 Mechanical	8
4.3 Environmental	8
Section 5 CONNECTOR ASSIGNMENTS	9
5.1 Main DIN Connector	9
5.1.1 HDSP Pin Functions	9
5.1.2 HDFU Pin Functions	9

Section 1 GENERAL

1.1 OVERVIEW

The iPack® 2202 series High Density Switch Pack – Flasher Unit (HDSP-FU) is a modular PCB-based plug-in load switch device providing six solid-state switches configured as two RYG channels to drive LED field signal loads in an Advanced Transportation Controller (ATC) Cabinet. When installed into a flasher location the Model 2202 provides four outputs configured as two channels of dual output wig-wag flasher operation.

The EDI iPack® series Model 2202 is available in High Voltage AC output (**2202-HV**), Very High Voltage AC output (**2202-VHV**) and Low Voltage DC output (**2202-LV**) versions. Unless otherwise specified, all information applies to all versions.

The model CMUip-2212 Cabinet Monitor Unit (CMU) is the principle part of the ATC Traffic Control Cabinet Monitoring System. It is resident in the Output Assembly and communicates with each HDSP located in the Output Assembly via Serial Bus #3. The role of the CMU is to query various cabinet conditions and, if the application requires action, the CMU will transfer control from the Advanced Traffic Controller (ATC) to a flashing control mode. The role of the HDSP is to drive the field signal heads and to collect voltage and load current data for each HDSP output and report this data to the CMU via Serial Bus #3. The role of the HDFU is to provide flashing outputs that drive the signals via Flash Transfer Relays during a cabinet flash mode. For further information concerning the CMU, see the Eberle Design **CMUip-2212 Operations Manual** (pn 888-2212-001).

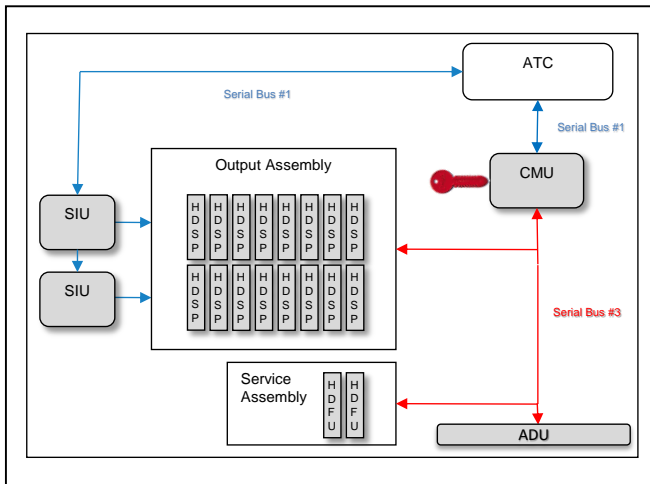

Figure 1

1.2 CHANNEL CONFIGURATION

In the HDSP mode, the Model 2202 will provide six outputs organized as two channels of Red, Yellow, and Green. In the HDFU mode, the Model 2202 will provide four outputs organized as two channels of flasher wig-wag outputs.

1.3 HDSP ADDRESSING

The address select input pins ADDRESS 4:0 define the Serial Bus #3 address of the HDSP as shown in Table 1. The pins are left open for a logical False, and are connected to ADDRESS COMMON for a logical True. The Serial Bus address is the binary value of the ADDRESS 4:0 inputs plus 1. The ADDRESS COMMON pin should be connected only to other ADDRESS 4:0 inputs in the assembly.

ADDR 4	ADDR 3	ADDR 2	ADDR 1	ADDR 0	SB #3 Address	Function	
False	False	False	False	False	0x01	Slot #1	Ch 1,2
False	False	False	False	True	0x02	Slot #2	Ch 3,4
False	False	False	True	False	0x03	Slot #3	Ch 5,6
False	False	False	True	True	0x04	Slot #4	Ch 7,8
False	False	True	False	False	0x05	Slot #5	Ch 9,10
False	False	True	False	True	0x06	Slot #6	Ch 11,12
False	False	True	True	False	0x07	Slot #7	Ch 13,14
False	False	True	True	True	0x08	Slot #8	Ch 15,16
False	True	False	False	False	0x09	Slot #9	Ch 17,18
False	True	False	False	True	0x0A	Slot #10	Ch 19,20
False	True	False	True	False	0x0B	Slot #11	Ch 21,22
False	True	False	True	True	0x0C	Slot #12	Ch 23,24
False	True	True	False	False	0x0D	Slot #13	Ch 25,26
False	True	True	False	True	0x0E	Slot #14	Ch 27,28
False	True	True	True	False	0x0F	Slot #15	Ch 29,30
False	True	True	True	True	0x10	Slot #16	Ch 31,32

Table 1

- WARNING -

The ATC must verify that all channels being driven by a Serial Interface Unit (SIU) are being monitored by an enabled HDSP, and that each HDSP is enabled by the programming in the CMU datakey.

Failure to provide this check may result in unmonitored load switch outputs. This could occur as a result of improper configuration of the cabinet, improper address assignment for one or more HDSP units, improper address assignment for one or more SIU units, or improper programming of the ATC.

1.4 HDFU ADDRESSING

The address select input pins ADDRESS 4:0 define the Serial Bus #3 address of the HDFU as shown in Table 2. The pins are left open for a logical False, and are connected to ADDRESS COMMON for a logical True. The Serial Bus address is the binary value of the

ADDRESS 4:0 inputs plus 1. The ADDRESS COMMON pin should be connected only to other ADDRESS 4:0 inputs in the assembly.

Flasher #2 is optional. If installed then it must be enabled in the CMU datakey programming.

<i>ADDR 4</i>	<i>ADDR 3</i>	<i>ADDR 2</i>	<i>ADDR 1</i>	<i>ADDR 0</i>	<i>SB #3 Address</i>	<i>Function</i>
True	False	False	False	False	Reserved	--
True	False	False	False	True	Reserved	--
True	False	False	True	False	Reserved	--
True	False	False	True	True	Reserved	--
True	False	True	False	False	Reserved	--
True	False	True	False	True	Reserved	--
True	False	True	True	False	Reserved	--
True	False	True	True	True	Reserved	--
True	True	False	False	False	Reserved	--
True	True	False	False	True	Reserved	--
True	True	False	True	False	Reserved	--
True	True	False	True	True	Reserved	--
True	True	True	False	False	Reserved	--
True	True	True	False	True	0x1E	HDFU #1
True	True	True	True	False	0x1F	HDFU #2
True	True	True	True	True	Reserved	--

Table 2

Section 2 HDSP FUNCTIONS

2.1 VOLTAGE SENSING

All field RMS voltage measurements are made over an RMS period of 33.3 milliseconds. A True RMS voltage measurement is made regardless of phase or wave-shape, including both positive and negative half wave sinusoids, over the voltage range of 0 to 135 (270) Vrms.

2.1.1 FIELD SIGNAL SENSING

The SENSE inputs provide the RMS voltages that are sent to the CMU. These pins should be connected to the Field Terminals of the cabinet such that they present the actual voltages being applied to the field wires and field LED signals. This sense point should be on the load side of any Flash Transfer Relay or fuse or other device.

The HDSP is designed such that unloaded Green, Yellow, or Red signal inputs are sensed as non-active signals.

2.1.2 FLASHER INPUT SENSING

Four inputs are provided for sensing of voltages at the FLASHER #1-1, FLASHER #1-2, FLASHER #2-1, and FLASHER #2-2 signal output terminals. This sense point should be on the input side of the Flash Transfer Relays.

2.1.3 SIGNAL POWER SENSING

The HDSP-FU monitors and reports the Signal Power voltage applied to SIGNAL (LV+ or HV+) input.

2.2 OUTPUT CURRENT SENSING

All field RMS current measurements are made over a period of 33.3 milliseconds. A True RMS current measurement is made regardless of phase or wave-shape, including both positive and negative half wave sinusoids, over the current range of 0 to 2 Arms.

2.3 +24VDC MONITOR SENSING

The HDSP senses the state of the +24VDC input. The +24VDC circuitry is with respect to DC (LOGIC) GROUND and electrically isolated from the MAINS and SIGNAL referenced circuitry.

2.4 HDSP OUTPUT OVERRIDE

The HDSP will force all outputs to the Off state if no SB #3 communications is received from the CMU for 1.75 seconds. This override is removed when SB #3 communications is resumed. The HDSP will also force all outputs to the Off state if the CMU has detected a fault state.

Note that the HDFU mode does not override the outputs.

2.5 DIAGNOSTIC ERROR

The HDSP is provided with a resident series of self-check diagnostic capabilities. When a Diagnostic Error is detected the HDSP will illuminate or flash the DIAGNOSTIC indicator on the front panel. All Diagnostic states below indicate a failure of the HDSP hardware or firmware and the unit should be removed from service for repair.

Flashes	Function
---------	----------

Solid	Failed State
1	3911 Error
2	Calibration Flash Error
3	3911 DR
4	3911 Offset
5	Calibration Data Error
6	Voltage Zero Offset

2.6 SERIAL BUS #3

2.6.1 ELECTRICAL

The SB #3 TX+, SB #3 TX- and SB #3 RX+, SB #3 RX- circuit pairs consist of two interface links conforming to the requirements of the Electronic Industries Association EIA-485, Standard for Electrical Characteristics of Generators and Receivers for use in Balanced Digital Multipoint Systems, dated April 1983.

All voltage potentials on the SB #3 interface links are referenced to the NEUTRAL pin. If provided, shields shall be terminated to Equipment Ground.

2.6.2 FRAME TYPES

The HDSP-FU is configured to respond to frame Types 01, 02, and 60. For details on frame definitions and protocol, refer to the documents referenced in Section 1.1.

Section 3

FRONT PANEL DESCRIPTION

3.1 INDICATORS

3.1.1 POWER INDICATOR

A green POWER indicator will illuminate to indicate the HV+ or LV+ MAINS input voltage is proper.

3.1.2 SB #3 RX & TX INDICATOR

A yellow SB #3 RX and TX LED indicator will pulse On each time the HDSP correctly receives or transmits a frame on Serial Bus #3. See Section 2.6

3.1.3 DIAGNOSTIC INDICATOR

A red DIAGNOSTIC indicator will illuminate or flash when the HDSP has detected an internal Diagnostic fault. This indicates a failure of the HDSP hardware or firmware and the unit should be removed from service for maintenance. See Section 2.4.

3.1.4 ID / FLASHER INDICATOR

3.1.5 ID INDICATOR

When the unit is operating as an HDSP, a blue LED (ID) will illuminate when the CMU wants to direct attention to that particular HDSP channel. The meaning of the active ID indicator is dependent on the context of the CMU.

3.1.6 FLASHER 1,2 INDICATORS

When the unit is operating as an HDFU, two blue LEDs (FLASHER 1,2) for each channel will illuminate to indicate an active Flasher output. The voltage level of the FL#x-x SENSE input is used to determine the active status of the LEDs such that they reflect actual flasher status to the field.

3.1.7 CHANNEL INPUT INDICATORS

A Red, Yellow, and Green LED indicator is provided for each channel input control. These inputs are driven by the SIU-2218 and are referenced to 24VDC and DC GROUND.

3.2 RESET BUTTON

Depressing the RESET button resets the HDSP-FU. When the RESET button is depressed all front panel indicators will be illuminated for 300 milliseconds.

3.2.1 SB #3 ADDRESS ASSIGNMENT REPORT

Continuously depressing the Reset button will provide a mode to display the SB #3 address. This count sequence will repeat as long as the RESET button is held depressed. The HDSP-FU will continue to operate normally in this mode.

- The Tx indicator will pulse to indicate the tens digit count.
- The Rx indicator will pulse to indicate the ones digit count.

For example, one pulse on Tx followed by five pulses on Rx is displayed for slot #15.

Section 4 SPECIFICATIONS

4.1 ELECTRICAL

Power Requirements (2202-HV)

HV+ MAINS Input Voltage	60 Vac Minimum
HV+ MAINS Input Voltage	135 Vac Maximum
HV+ MAINS Input Frequency	47 to 63 Hz
Power Consumption (MAINS only)	2 Watt Maximum

Power Requirements (2202-LV)

LV+ MAINS Input Voltage	30 Vdc Minimum
LV+ MAINS Input Voltage	60 Vdc Maximum
Power Consumption (MAINS only)	1 Watt Maximum

Power Requirements (2202-VHV)

HV+ MAINS Input Voltage	120 Vac Minimum
HV+ MAINS Input Voltage	270 Vac Maximum
HV+ MAINS Input Frequency	47 to 63 Hz
Power Consumption (MAINS only)	2 Watt Maximum

Field Outputs (2202-HV)

Output Drive (HDSP mode)	1 Amp
Output Drive (HDFU mode)	2 Amp
HV+ Signal Voltage	135 Vrms Maximum

Field Outputs (2202-LV)

Output Drive (HDSP mode)	2 Amp
Output Drive (HDFU mode)	3 Amp
LV+ Signal Voltage	60 Vdc Maximum

Field Outputs (2202-VHV)

Output Drive (HDSP mode)	1 Amp
Output Drive (HDFU mode)	2 Amp
HV+ Signal Voltage	270 Vrms Maximum

AC Voltage Monitors (2202-HV)

Field SENSE Inputs	135 Vrms Maximum
Flasher SENSE Inputs	135 Vrms Maximum
Flasher LED Active	greater than 70 Vrms
Flasher LED Not Active	less than 50 Vrms
Accuracy	± 2%

DC Voltage Monitors (2202-LV)

Field SENSE Inputs	60 Vdc Maximum
Flasher SENSE Inputs	60 Vdc Maximum
Flasher LED Active	greater than 43 Vrms
Flasher LED Not Active	less than 41 Vrms
Accuracy	± 2%

AC Voltage Monitors (2202-VHV)

Field SENSE Inputs	270 Vrms Maximum
Flasher SENSE Inputs	270 Vrms Maximum
Flasher LED Active	greater than 140 Vrms
Flasher LED Not Active	less than 100 Vrms
Accuracy	± 2%

AC Current Monitors

Field Signal Input Range (2202-HV).....	2 Arms Maximum
Field Signal Input Range (2202-LV)	3 Arms Maximum
Field Signal Input Range (2202-VHV)	2 Arms Maximum
Accuracy	± 2%

DC Input Control

Active (True)	less than 6 Vdc
Not Active	greater than 16 Vdc

+24VDC Monitor

Fault	less than 18Vdc
No Fault	greater than 22Vdc

Logic Inputs

Address 0:4 (Reference Address Common)

Active (True)	less than 6 Vdc
Not Active (False)	greater than 16 Vdc

4.2 MECHANICAL

Height	4.50 inches
Width.....	1.12 inches
Depth	6.50 inches

4.3 ENVIRONMENTAL

Storage Temperature Range	-45 to +85 °C
Operating Temperature Range	-34 to +74 °C
Humidity (non-condensing).....	0 to 95% Relative

Section 5 CONNECTOR ASSIGNMENTS

5.1 MAIN DIN CONNECTOR

The connector is a male DIN 41612 Type E series, 48-pin connector. The Rx and Tx signal names are with respect to the HDSP-FU.

5.1.1 HDSP PIN FUNCTIONS

Pin	A (Bottom Row)	C (Middle Row)	E (Top Row)
2	Ch 1 Red In	Ch 1 Yellow In	Ch 1 Green In
4	Ch 2 Red In	Ch 2 Yellow In	Ch 2 Green In
6	+24VDC	DC Ground	Address 4
8	Equipment Ground	Neutral	Neutral
10	SB #3 Rx+	SB #3 Tx+	Address Common
12	SB #3 Rx-	SB #3 Tx-	Address 3
14	Address 0	Address 1	Address 2
16	Ch 1 Red Sense	Ch 1 Red Out	Ch 1 Red Out
18	Ch 1 Yellow Sense	Ch 1 Yellow Out	Ch 1 Yellow Out
20	Ch 1 Green Sense	Ch 1 Green Out	Ch 1 Green Out
22	Ch 2 Red Sense	Ch 2 Red Out	Ch 2 Red Out
24	Ch 2 Yellow Sense	Ch 2 Yellow Out	Ch 2 Yellow Out
26	Ch 2 Green Sense	Ch 2 Green Out	Ch 2 Green Out
28	LV+ Signal	LV+ Signal	LV+ Signal
30	HV+ Signal	HV+ Signal	HV+ Signal
32	LV+ MAINS	Neutral	HV+ MAINS

5.1.2 HDFU PIN FUNCTIONS

Pin	A (Bottom Row)	C (Middle Row)	E (Top Row)
2	Reserved	Reserved	Ch 1 Aux In
4	Ch 2 Aux In	Reserved	Reserved
6	+24VDC	DC Ground	Address 4
8	Equipment Ground	Neutral	Neutral
10	SB #3 Rx+	SB #3 Tx+	Address Common
12	SB #3 Rx-	SB #3 Tx-	Address 3
14	Address 0	Address 1	Address 2
16	FL#1-1 Sense	FL#1-1 Out	FL#1-1 Out
18	FL#1-2 Sense	FL#1-2 Out	FL#1-2 Out
20	Ch 1 Aux Sense	Ch 1 Aux Out	Ch 1 Aux Out
22	Ch 2 Aux Sense	Ch 2 Aux Out	Ch 2 Aux Out
24	FL#2-1 Sense	FL#2-1 Out	FL#2-1 Out
26	FL#2-2 Sense	FL#2-2 Out	FL#2-2 Out
28	LV+ Signal	LV+ Signal	LV+ Signal
30	HV+ Signal	HV+ Signal	HV+ Signal
32	LV+ MAINS	Neutral	HV+ MAINS