



PLA

PREFORMED LOOP FOR ACCESS CONTROL

The PLA is designed to maximize durability and maintain a flexible form that is easy to install and handle.

FEATURES

- Installs in 1/8" wide saw cut
- Wire insulation is Cross-linked Polyethylene (XLPE)
- All splice connections are soldered, sealed and tested during fabrication

HIGHLIGHTS

- No need to cut 45° corners
- Design ensures an exact fit of the loop in the saw cut
- Loop / Lead-in cables are flexible for easy handling and installation
- 10-year limited warranty

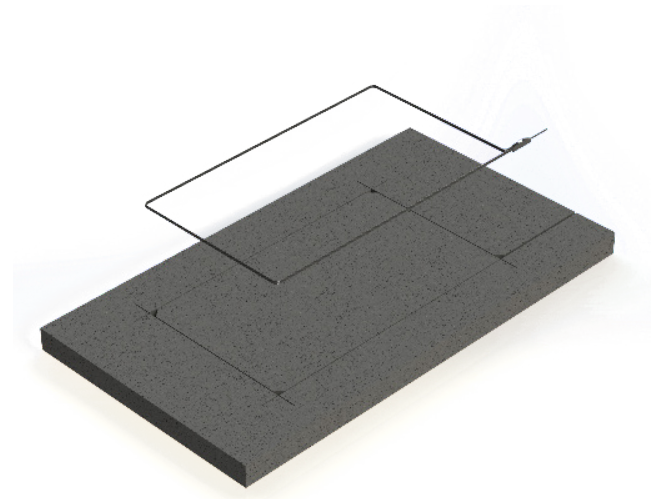

Overview

The RENO PLA Preformed Loop is a prefabricated loop / lead-in assembly designed to be installed in a 1/8" (0.32 cm) saw cut or wider. The PLA is designed to maximize durability and maintain a flexible form that is easy to install and handle. All wire insulation is constructed with the optimal thickness of Cross-linked Polyethylene (XLPE) necessary to ensure a long, trouble free life. XLPE insulation provides excellent thermal, electrical, and physical properties and is recognized for its outstanding resistance to moisture and chemicals.

Ordering Information

Model PLA-X₁-X₂

X₁ = Loop Perimeter (feet)

X₂ = Lead-in Length (feet)

Note: Two extra feet of the four conductor loop cable is added during manufacturing process. The extra cable allows for variations in the saw cut. The extra cable is placed in the lead-in saw cut.



Specifications

Two Conductor Lead-In Cable

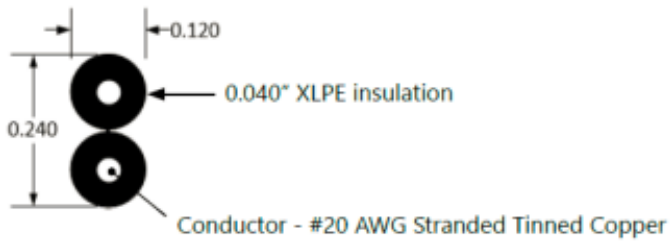

Four Conductor Loop Cable

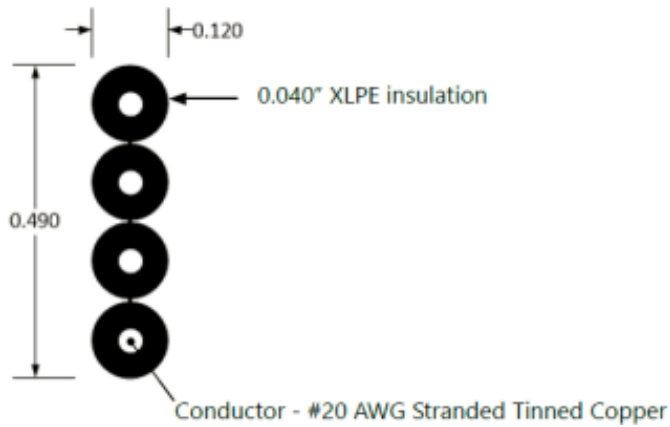

Installation Methods

Method 1

Mark and drill 1" hole 3" before the splice joint. Widen the lead-in saw cut to 1/4" to accommodate the loop cables. Fill hole with sand to top of the splice joint.

Splice Joint installed In 1" Hole



Method 2

Mark 3" after the splice joint. Widen the lead-in saw cut to 1/4" to accommodate the loop cables.

Splice Joint Installed In Lead-In Saw Cut

