

SSM-LE Series

NEMA TS-1 Enhanced Signal Monitor Operations Manual

THIS MANUAL CONTAINS TECHNICAL INFORMATION FOR THE **SSM-6LE**, **SSM-6LEip**, **SSM-6LEC**, **SSM-12LE**, **SSM-12LEip**, and **SSM-12LEC** SERIES SIGNAL MONITOR.

REVISION: MARCH 2012

pn 888-1216-002



EBERLE DESIGN INC.

3510 East Atlanta Avenue
Phoenix, AZ 85040 USA
www.EDITraffic.com

Tel (480) 988-6407
Fax (602) 437-1996



THE SSM-LE SERIES SIGNAL MONITOR IS DESIGNED AND MANUFACTURED
IN THE USA BY EBERLE DESIGN INC.

PHOENIX, ARIZONA

EDI IS CERTIFIED TO ISO 9001:2008 QUALITY SYSTEMS STANDARDS.

INFORMATION CONTAINED HEREIN IS PROPRIETARY TECHNICAL INFORMATION
OF EBERLE DESIGN INC. PUBLICATION, REPRODUCTION OR USE IN WHOLE OR
PART IS NOT PERMITTED EXCEPT UNDER TERMS AGREED UPON IN WRITING.

© COPYRIGHT 2012 EDI.

MAINTENANCE NOTE

**THIS SIGNAL MONITOR UNIT HAS BEEN CAREFULLY INSPECTED
AND TESTED TO ENSURE PROPER OPERATION. IT IS
RECOMMENDED THAT THE MALFUNCTION MANAGEMENT UNIT
BE TESTED AT LEAST ANNUALLY TO ENSURE PROPER
OPERATION AND COMPLIANCE WITH FACTORY SPECIFICATIONS.**

Table of Contents

Section 1 General	1
1.1 Description	1
1.2 Advanced Feature Overview	1
1.2.1 Liquid Crystal Status and Field Display	1
1.2.2 RMS Voltage Reporting	1
1.2.3 <i>ECcom</i> Software Interface	1
1.2.4 Flashing Yellow Arrow (FYA) Protected-Permissive Movement	2
1.3 General	2
1.4 Field Signal Terminals	2
1.4.1 <i>LEDguard</i> [®] LED Field Signal Sensing	3
Section 2 Standard NEMA Functions	4
2.1 Conflict Monitoring	4
2.2 Red Fail Monitoring	4
2.2.1 Red Enable Input	4
2.2.2 Walk Disable Option	4
2.3 DC Voltage Monitoring	4
2.3.1 +24Vdc Supply Monitoring	4
2.3.1.1 +24Vdc Monitor Inhibit Input	5
2.3.1.2 +24Vdc Monitor Latch Input	5
2.3.2 Controller Voltage / Fault Monitor Input	5
2.3.2.1 CVM Monitor Latch Input	5
2.3.2.2 CVM Log Disable	5
2.4 Power Failure Detection	5
Section 3 Enhanced Features	7
3.1 Hardware Features	7
3.2 Dual Indication Monitoring	7
3.2.1 GY ENABLE Option	8
3.2.2 Walk Disable Option	8
3.3 Minimum Yellow Clearance Monitoring	8
3.4 External Watchdog Monitoring	8
3.5 Program Card Absent Indication	8
3.6 Reset Input Detection	9
3.7 Internal Diagnostics	9
3.8 Real Time Clock / Calendar	9
3.9 Display LED Test	9
3.10 Recurrent Pulse Detection	9
3.11 Flashing Yellow Arrow Protected-Permissive Monitoring (FYA)	10
3.11.1 Basic FYA MODE	11
3.11.2 Compact FYAc MODE	12
3.11.3 FYA Channel Assignment Diagrams	13
Section 4 <i>ECcom</i> Interface	14
4.1 EDI <i>ECcom</i> Monitor Reports	14
4.1.1 General Data	14
4.1.2 Current Status (S)	14
4.1.3 Previous Fault (PF) Event Log	14
4.1.4 AC Line (AC) Event Log	14
4.1.5 Manual Reset (MR) Event Log	14
4.1.6 Configuration (CF) Event Log	15
4.1.7 Signal Sequence Event Log	15
4.2 Ethernet LAN Port	15
Section 5 Installation	16
5.1 Permissive Channel Programming	16
5.2 Minimum Flash Time Programming	16

5.3 SSM Switch Programming.....	16
5.4 Unit Option Programming.....	17
5.4.1 GY ENABLE Option.....	17
5.4.2 LEDguard® Enable Option.....	17
5.4.3 External Watchdog Enable Option.....	17
5.4.4 Walk Disable Option.....	17
5.4.5 Controller Voltage Monitor (CVM) Latch Programming.....	17
5.4.6 24VDC Monitor Latch Programming.....	17
5.4.7 Log CVM FAULTS Option.....	17
5.4.8 Flashing Yellow Arrow Monitor.....	17
Section 6 Front Panel Description.....	18
6.1 Fault Status Display.....	18
6.1.1 CONFLICT Indicator.....	18
6.1.2 RED FAIL Indicator.....	18
6.1.3 CVM / WD Indicator.....	18
6.1.4 24V-1 Indicator.....	18
6.1.5 24V-2 Indicator.....	18
6.1.6 RP STATUS Indicator.....	18
6.1.7 PROGRAM CARD Indicator.....	18
6.1.8 DUAL INDICATION Indicator.....	18
6.1.9 CLEARANCE Indicator.....	19
6.1.10 Time and Date Indicator.....	19
6.1.11 RE OFF Indicator.....	19
6.1.12 RX Indicator.....	19
6.1.13 TX Indicator.....	19
6.1.14 PREV FAIL Indicator.....	19
6.2 Field Status Display.....	19
6.3 LED Status Display.....	19
6.3.1 POWER Indicator.....	19
6.3.2 FAULT Indicator.....	20
6.3.3 DIAGNOSTIC Indicator.....	20
6.4 Buttons.....	20
6.4.1 RESET Button.....	20
6.4.2 MODE Button.....	20
6.4.3 INC Button.....	20
6.5 Display Modes.....	20
6.5.1 Previous Fault Display Mode (PF Data Log).....	20
6.5.2 AC Data Log Display Mode (AC Data Log).....	21
6.5.3 Configuration Display Mode.....	21
6.5.4 Clock Set Display Mode.....	21
6.6 Clearing the Data Logs.....	21
Section 7 Specifications.....	22
7.1 Electrical.....	22
7.1.1 Power Requirements.....	22
7.1.2 AC Voltage Monitors.....	22
7.1.3 Power Fail Monitor.....	22
7.1.4 DC Voltage Monitor.....	22
7.1.5 Logic Inputs.....	22
7.2 Mechanical.....	22
7.3 Environmental.....	22
7.4 Timing Functions.....	23
Section 8 Wiring Assignments.....	24
8.1 SSM-12LE Harnessing Connectors.....	24
8.1.1 SSM-12LE Connector MS-A Pin Terminations.....	24
8.1.2 SSM-12LE Connector MS-B Pin Terminations.....	25
8.2 SSM-6LE Harnessing Connector.....	26
8.2.1 SSM-6LE Connector MS-A Pin Terminations.....	26

8.3 EIA-232 Connector.....27
 8.3.1 EIA-232 Cable to a PC.....28
8.4 Ethernet LAN Port.....28
 8.4.1 Ethernet LAN Cable.....28

Section 1 General

1.1 DESCRIPTION

The SSM-LE series Signal Monitors consists of two models; the SSM-6LE, and SSM-12LE. The SSM-6LE is a six channel unit and the SSM-12LE is a twelve channel unit. Both models provide the same operational functions and features including advanced NEMA Aplus® fault coverage, a full intersection liquid crystal display (LCD), comprehensive event logging and signal sequence reporting, and true RMS voltage measuring and reporting. A serial communications port is provided on all units that interfaces with the EDI *ECcom* Signal Monitor Communications software running on a personal computer. Where not specified otherwise, the information in this manual will apply to both models.

The SSM-LE Series Signal Monitor is a device used in a Traffic Controller Assembly to accomplish the detection of, and response to improper and conflicting signals and improper operating voltages in a Controller Assembly caused by malfunctions of the Controller Unit (CU), load switches, or mis-wiring of the cabinet. The SSM-LE Series also provides error sensing of two +24Vdc cabinet supplies and the controller power supplies via +24V MONITOR I, +24V MONITOR II, and Controller Voltage Monitor (CVM) inputs respectively. The Eberle Design SSM-LE Series is directly interchangeable with a standard NEMA Signal Monitor and meets with or exceeds all specifications outlined in Section 6 (Conflict Monitor) of the National Electrical Manufacturers Association (NEMA) **Standards Publication TS1-1989 R2005, Traffic Control Systems.**

1.2 ADVANCED FEATURE OVERVIEW

1.2.1 LIQUID CRYSTAL STATUS AND FIELD DISPLAY

The SSM-LE Series uses a Liquid Crystal Display (LCD) to show monitor status and two icon based LCDs to show field signal channel and fault status. This versatile display system provides a service technician with both detailed information regarding cabinet status and configuration, and at the same time an easily read field signal status display showing full intersection status.

1.2.2 RMS VOLTAGE REPORTING

Input voltages are measured using a true Root Mean Squared (RMS) technique. A dedicated Digital Signal Processor (DSP) RMS-Engine controls the analog to digital (A/D) hardware which samples each AC input voltage a minimum of 32 times per cycle. The RMS-Engine then calculates the true RMS voltage value producing accurate results which are very insensitive to changes in frequency, phase, wave shape, and distortion.

1.2.3 ECCOM SOFTWARE INTERFACE

The field proven EDI *ECcom* Signal Monitor Communications software provides a laptop computer or system interface to all information contained in the monitor. This includes detailed status, voltages, configuration, as well as historical event logs, and five thirty second Signal Sequence logs.

Event logs provide a historical record of previous fault data, ac line event data, monitor reset events, and configuration programming change events. These logs are invaluable when analyzing fault data to diagnose cabinet equipment malfunctions.

The Signal Sequence logs provide a graphical display of the signal states of all sixteen channels for up to thirty seconds prior to the fault trigger point at 50 millisecond resolution. The SSM-LE Series stores these signal records for the last five fault events.

The EDI *ECcom* software is available at no charge from the EDI web site at **www.EDIttraffic.com**.

1.2.4 FLASHING YELLOW ARROW (FYA) PROTECTED-PERMISSIVE MOVEMENT

The SSM-LE Series is designed to monitor an intersection with up to four approaches using the four section Flashing Yellow Arrow (FYA) movement outlined by the NCHRP Research Project 3-54 on Protected/Permissive signal displays with Flashing Yellow Arrows. Two cabinet configurations are supported depending on the number of load switches provided and the capabilities of the Controller Unit. In both modes the SSM-LE Series has been designed to provide the same broad fault coverage for the FYA approaches as it does for conventional protected left turn phases including Conflict, Red Fail, Dual Indication, and Minimum Yellow Clearance monitoring.

See section 3.11 for programming information.

1.3 GENERAL

The SSM-LE Series is configured as a 6 channel (SSM-6LE) monitor or a 12 channel (SSM-12LE) when operated in a TS-1 type cabinet assembly. Each channel has the capability of monitoring a Green, a Yellow, a Red, and a Walk field signal output at the Terminals and Facilities field terminals.

A Program Card is provided for assigning permissive channels. The SSM-LE Series detects the presence of conflicting Green or Yellow or Walk field signal inputs between any two or more channels not assigned to be permissive on the Program Card. The RED ENABLE input, when activated, enables the Red Fail Monitoring functions of the unit causing the monitor to trigger when it detects the absence of voltage on all three (four) of the field signal inputs of a channel. It also enables the Minimum Yellow Clearance Monitoring function which verifies that the Yellow Change Clearance interval between the end of an active Green signal and the beginning of the Red signal is proper. The monitoring circuitry is capable of detecting either full wave or positive and negative half-wave sinusoidal field signal inputs at the specified voltage levels.

When triggered by the detection of a fault condition which exists longer than the minimum period defined by the NEMA **Standards Publication TS1-1989 R2005** the SSM-LE Series will enter the fault mode causing the OUTPUT relay to de-energize and two sets of contacts on the OUTPUT relay to transfer. The cabinet assembly should be wired such that the closure of the OUTPUT relay contacts will cause an automatic switching of the field signal outputs from normal operation to flashing operation. The SSM-LE Series will then display the appropriate fault status. The loss of AC LINE will not reset the fault mode of the OUTPUT relay contacts. In the event of AC LINE loss the SSM-LE Series will retain the status of all fault and channel indicators and will display the correct fault and channel status upon restoration of AC LINE.

1.4 FIELD SIGNAL TERMINALS

A GREEN, YELLOW, or WALK field signal input will be sensed as active by the unit when it exceeds the Green, Yellow, or Walk Signal Detect voltage threshold (Section 7.1.2) and a field signal input will be sensed as inactive when it is less than the Green, Yellow, or Walk Signal No-Detect voltage threshold (Section 7.1.2). Both positive and negative half wave rectified inputs will be sensed.

A RED (DON'T WALK) field signal input will be sensed as active by the unit when it exceeds the Red Signal Detect voltage threshold (Section 7.1.2) and a field signal input will be sensed as inactive when it is less than the Red Signal No-Detect voltage threshold (Section 7.1.2). Both positive and negative half wave rectified inputs will be sensed.

NOTE: When the circuit connected to the sensing input of an MMU exhibits high impedance characteristics such as caused by dimmers, burned out lamps, low wattage equipment, or no load, it may be necessary to place a low impedance device external to the unit between the MMU input and AC NEUTRAL (See Sections 5.5.3.9 and 6.2.4 of **NEMA**

Standards Publication TS2-2003 v02.06, Traffic Controller Assemblies With NTCIP Requirements).

1.4.1 LEDGUARD® LED FIELD SIGNAL SENSING

The Eberle Design SSM-LE Series can be configured to use a technique called *LEDguard*® that is designed to better monitor the characteristics of LED based signal loads (See Section 5.4.2). Each field signal input is measured and compared to both a high threshold and a low threshold value to determine On / Off status. This differs from conventional standard NEMA operation where the active threshold is picked according to the color of the field signal. Once the high and low On / Off thresholds (Section 7.1.2) have been determined using the input RMS voltage, the individual fault monitor functions use the appropriate threshold to determine if a fault condition exists.

LEDguard®	Green/Walk	Yellow	Red/Don't Walk
Conflict	Low	Low	---
Red Fail	High	High	High
Dual Indication	Low	Low	Low
Clearance	Low	Low	High

A paper with further information on the EDI *LEDguard*® function can be found in the Support section of the EDI web site, www.EDItraffic.com.

Section 2 Standard NEMA Functions

2.1 CONFLICT MONITORING

When voltages on any conflicting channels are sensed as active for more than the Conflict Fault time (7.4), the SSM-LE Series will enter the fault mode, transfer the OUTPUT relay contacts to the Fault position, and display the CONFLICT status screen. The SSM-LE Series will remain in the fault mode until the unit is reset by the RESET button or the EXTERNAL RESET input. When voltages on any conflicting channels are sensed as active for less than the Conflict No-Fault time, the SSM-LE Series will not transfer the OUTPUT relay contacts to the Fault position.

The SSM-LE Series is fully programmable and requires the use of soldered wire jumpers on an interchangeable Programming Card to define permissive channel pairs. See Section 5.1 for Programming Card details.

2.2 RED FAIL MONITORING

When voltages on all inputs (G, Y, R, W) to a channel are sensed as inactive for more than the Red Fail Fault time (7.4), the SSM-LE Series will enter the fault mode, transfer the OUTPUT relay contacts to the Fault position, and display the RED FAIL status screen. The SSM-LE Series will remain in the fault mode until the unit is reset by the RESET button or the EXTERNAL RESET input. When voltages on all inputs to a channel are sensed as inactive for less than the Red Fail No-Fault time, the SSM-LE Series will not transfer the OUTPUT relay contacts to the Fault position.

Red Fail Monitoring will be disabled when the RED ENABLE input is not active.

2.2.1 RED ENABLE INPUT

The RED ENABLE input will be sensed as active by the SSM-LE Series when it exceeds the Red Enable Input threshold (Section 7.1.2). The presence of the proper operating voltage at this input enables Red Fail Monitoring, Minimum Yellow Clearance Monitoring, and Dual Indication Monitoring.

The main status screen will display "RE OFF" if the RED ENABLE input is not active.

2.2.2 WALK DISABLE OPTION

This option will modify the operation of Red Fail and Dual Indication Monitoring. When enabled, the Red Fail and Dual Indication Monitoring function will not monitor the Walk field outputs. Absence of signals on the Green, Yellow, and Red field outputs of a channel will place the SSM-LE Series into the Red Fail fault mode causing the Output relay contacts to transfer. Presence of active signals on the Walk outputs will not cause a Dual Indication when concurrent with active Red or Yellow signals. This function is enabled by the Option Switch called "WALK DISABLE". See Section 5.4.4.

2.3 DC VOLTAGE MONITORING

2.3.1 +24VDC SUPPLY MONITORING

The +24V MONITOR I and +24V MONITOR II inputs are provided for monitoring two +24Vdc supplies in the cabinet assembly. Should loss of proper voltage occur at either of these inputs, the SSM-LE Series will enter the fault mode, transfer the OUTPUT relay contacts to the Fault position, and display the appropriate 24V-1 or 24V-2 status screen. The SSM-LE Series will automatically reset the OUTPUT relay when the correct input voltages are restored to both of these inputs. The SSM-LE Series will remain in the fault mode for at least the time determined by the Minimum Flash programming.

A voltage greater than the +24V Monitor input threshold (Section 7.1.4) applied to both of the +24V MONITOR inputs will be sensed by the SSM-LE Series as adequate for operation of the cabinet assembly. A voltage less than the +24V Monitor input threshold applied to either of the +24V MONITOR inputs will be sensed as inadequate for proper operation. When a +24V MONITOR input is sensed as inadequate for more than the +24V Monitor Fault time (7.4), the SSM-LE Series will enter the fault mode and transfer the OUTPUT relay contacts to the Fault position. When a +24V MONITOR input is sensed as inadequate for less than the +24V Monitor No-Fault time, the SSM-LE Series will not transfer the OUTPUT relay contacts to the Fault position. A +24Vdc failure during the programmed Minimum Flash time or during a Power Failure will not cause a fault condition.

2.3.1.1 +24VDC MONITOR INHIBIT INPUT

A +24V MONITOR INHIBIT input is provided to inhibit the operation of the +24Vdc Monitor. Application of a logic TRUE (low) state to this input will disable the operation of the +24Vdc Monitor.

2.3.1.2 +24VDC MONITOR LATCH INPUT

An Option Switch is supplied on the front panel to allow +24Vdc failures to latch in the fault condition until the unit is reset by the activation of the RESET button or the EXTERNAL RESET input. See Section 5.4.5. A +24Vdc failure during the programmed Minimum Flash time or during a Power Failure will not cause a latched fault condition.

2.3.2 CONTROLLER VOLTAGE / FAULT MONITOR INPUT

This input is to be connected to the CONTROLLER UNIT VOLTAGE MONITOR (CVM) output from the Controller Unit. When the TRUE (low) state is absent for more than the CVM Fault time (7.4), the SSM-LE Series will enter the fault mode, transfer the OUTPUT relay contacts to the Fault position, and display the CVM status screen. When the TRUE (low) state is absent for less than the CVM No-Fault time, the SSM-LE Series will not transfer the OUTPUT relay contacts to the Fault position. The SSM-LE Series will automatically reset the OUTPUT relay when the True (low) state is restored to the input. The SSM-LE Series will remain in the fault mode for at least the time determined by the Minimum Flash programming. A CVM failure during the programmed Minimum Flash time or during a Power Failure will not cause a fault condition.

2.3.2.1 CVM MONITOR LATCH INPUT

An Option Switch is supplied on the front panel to allow CVM failures to latch in the fault condition until the unit is reset by the activation of the RESET button or the EXTERNAL RESET input. See Section 5.4.5. A CVM failure during the programmed Minimum Flash time or during a Power Failure will not cause a latched fault condition.

2.3.2.2 CVM LOG DISABLE

If CVM events are not related to a malfunction condition and occur on a regular basis such as Time of Day flash, the logging of these events can be disabled. See Section 5.4.7.

2.4 POWER FAILURE DETECTION

When the AC LINE voltage is below the minimum AC Line drop-out level (Section 7.1.2) for the Power Fail Respond time (7.4), the SSM-LE Series will suspend all fault monitoring functions, de-energize the OUTPUT relay, and de-energize the START relay. The POWER indicator on the front panel will flash at a rate of 2Hz to indicate the low voltage status.

When the AC LINE voltage returns above the maximum AC Line restore level (Section 7.1.2) for the Power Fail Restore time (7.4), the monitor will resume normal operation and the POWER indicator on the front panel will remain illuminated. After a 2.5 ±0.5 second delay the START relay will be energized. After a programmable delay determined by the Minimum Flash programming (see Section 5.2), the OUTPUT relay will be energized.

This expanded operating voltage range for cabinet components allows the SSM-LE Series to place the intersection into flash and return to normal operation in an orderly manner when the AC LINE voltage is sufficient for proper operation. The SSM-LE Series should be the first component in the cabinet to sense a low voltage condition and the last component to sense a proper AC LINE operating voltage.

The AC LINE and AC NEUTRAL inputs are used to generate the internal voltage supplies required to operate the monitor. AC NEUTRAL also serves as the return for all AC signals including RED ENABLE. EARTH GROUND provides an independent connection to the chassis of the unit and is isolated from AC NEUTRAL and LOGIC GROUND. LOGIC GROUND is provided for inputs which are isolated from AC NEUTRAL (i.e. +24V Monitors, CVM, CONTROLLER WATCHDOG, EXTERNAL RESET, and 24V MONITOR INHIBIT). LOGIC GROUND may be tied to AC NEUTRAL if desired.

Section 3 Enhanced Features

The following enhanced features are provided on the Eberle Design SSM-LE Series for additional monitoring functions and to increase the reliability of the SSM-LE Series monitor operation.

3.1 HARDWARE FEATURES

The SSM-LE Series is a dual microprocessor based unit. All monitoring functions and features are firmware programmable which permits upgrades or modifications by simply reprogramming the Flash memory device containing the firmware with the upgraded version. Thus, most changes to the SSM-LE Series specifications may be accommodated without modifying the hardware.

Since all critical timing functions are accomplished by the microprocessor, the quartz crystal based accuracy results in very precise and repeatable measurements. This accuracy is maintained on functions from timing fault conditions to implementing a unique firmware based digital sampling and filtering algorithm. This algorithm is applied to all AC field signals to help eliminate false detection in a "noisy" AC line environment.

Input voltages are measured using a true Root Mean Squared (RMS) technique. A dedicated microcontroller RMS-Engine controls the analog to digital (A/D) hardware that samples each AC input voltage at least 32 times per cycle. The RMS-Engine then calculates the true RMS voltage value, producing accurate results which are very insensitive to changes in frequency, phase, wave shape, and distortion. Voltage references are temperature compensated for constant voltage levels within the operating temperature range.

A nonvolatile EEPROM device is utilized to retain fault status information and event logs through an AC Line power interruption. The correct fault indications will be displayed upon restoration of AC Line power. This EEPROM device requires no battery back-up. The time of day in the SSM-LE Series is stored in a battery-backed real time clock circuit. Should this battery fail, only current time of day and date information will be lost. No monitor configuration programming is stored under battery power.

3.2 DUAL INDICATION MONITORING

This monitoring function detects simultaneous input combinations of active Green and Yellow, Green and Red, Yellow and Red, Walk and Yellow, or Walk and Red field signal inputs on the same channel. When voltages on any two inputs of a channel are sensed as active for more than the Dual Indication Fault time (7.4), the SSM-LE Series will enter the fault mode, transfer the OUTPUT relay contacts to the Fault position, and display the DUAL INDICATION status screen. The SSM-LE Series will remain in the fault mode until the unit is reset by the RESET button or the EXTERNAL RESET input. When voltages on any two inputs of a channel are sensed as active for less than the Dual Indication Fault time, the SSM-LE Series will not transfer the OUTPUT relay contacts to the Fault position.

Dual Indication Monitoring may anticipate and prevent a possible conflicting signal display in the intersection in the event that a proceed signal on the current phase hangs up and is constantly detected as active. An open or no load condition (i.e., burned-out bulb) may be also detected as an active signal depending on the output impedance characteristics of the load switch (i.e. load switch leakage current), and may cause a Dual Indication Fault.

Dual Indication Monitoring will be disabled when the RED ENABLE input is not active. A set of switches labeled "SSM" is provided on the SSM-LE series Signal Monitor front panel to enable Dual Indication Monitoring on a per channel basis. See Section 5.3 for the programming procedure.

3.2.1 GY ENABLE OPTION

This monitoring function detects simultaneous inputs of active Green and Yellow field signal inputs on the same channel. It can be used to monitor channels which have an unused Red field signal input tied to AC LINE such as a five section signal head resulting in the SSM switch in the Off position.

GY-Dual Indication Monitoring is enabled by the front panel option switch labeled GY ENABLE. See Section 5.4.1. When the GY-Dual Indication Monitoring option is enabled, all channels which have the front panel SSM switches OFF will be individually monitored for simultaneous active Green and Yellow field signal inputs. All channels which have the front panel SSM switches ON (i.e. enabled for Dual Indication Monitoring) will function as described above in Section 3.2.

GY-Dual Indication Monitoring will be disabled when the RED ENABLE input is not active.

3.2.2 WALK DISABLE OPTION

This option will modify the operation of Red Fail and Dual Indication Monitoring. When enabled, the Red Fail and Dual Indication Monitoring function will not monitor the Walk field outputs. Absence of signals on the Green, Yellow, and Red field outputs of a channel will place the SSM-LE Series into the Red Fail fault mode causing the Output relay contacts to transfer. Presence of active signals on the Walk outputs will not cause a Dual Indication when concurrent with active Red or Yellow signals. This function is enabled by the Option Switch called "WALK DISABLE" on the front panel. See Section 5.4.4.

3.3 MINIMUM YELLOW CLEARANCE MONITORING

The SSM-LE Series will verify that the Yellow Change interval is at least the Clearance Fail Fault time (7.4). The Yellow Change interval consists of the duration of time in which the Yellow field signal input is active in a sequence from Green to Yellow to Red. When this minimum interval is not satisfied the SSM-LE Series will enter the fault mode, transfer the OUTPUT relay contacts to the Fault position, and display the CLEARANCE status screen. The SSM-LE Series will remain in the fault mode until the unit is reset by the RESET button or the EXTERNAL RESET input.

Minimum Yellow Change Monitoring will be disabled when the RED ENABLE input is not active. A set of switches labeled "SSM" is provided on the SSM-LE series Signal Monitor front panel to enable Clearance Monitoring on a per channel basis.

3.4 EXTERNAL WATCHDOG MONITORING

This function monitors an optional external watchdog output from a Controller Unit or other external cabinet circuitry. The external source should toggle the EXTERNAL WATCHDOG input logic state once every 100 msec. If the SSM-LE Series does not receive a change in state on the EXTERNAL WATCHDOG input for the External Watchdog Fault time (7.4), the SSM-LE Series will enter the fault mode, transfer the OUTPUT relay contacts to the Fault position, and display the EXT WATCHDOG status screen. The SSM-LE Series will remain in the fault mode until the unit is reset by the RESET button or the EXTERNAL RESET input. A Power Failure will also reset the External Watchdog fault state of the monitor (see Section 2.4).

This function is enabled by the front panel Option Switch called WD ENABLE (see Section 5.4.3). The EXTERNAL WATCHDOG input is harnessed to spare pin MSB-S on the front panel B connector by the factory.

3.5 PROGRAM CARD ABSENT INDICATION

If the Program Card is absent or not seated properly in the edge connector, the SSM-LE Series will enter the fault mode, transfer the OUTPUT relay contacts to the Fault position,

and display the PROGRAM CARD status screen. The SSM-LE Series will remain in the fault mode until the Program Card is correctly seated and the SSM-LE Series is reset by the RESET button or the EXTERNAL RESET input.

3.6 RESET INPUT DETECTION

Activation of the front panel RESET button or the EXTERNAL RESET input will reset the SSM-LE Series from the fault mode and cause the START relay to energize and the OUTPUT relay to transfer to the no-fault state. Each activation of the RESET button or EXTERNAL RESET input will cause a one time reset input to the unit. A continuously activated RESET input will not prevent the SSM-LE Series from monitoring any fault condition and/or transferring the OUTPUT relay contacts to the fault position. This function prevents the Cabinet Assembly from being operated with the monitor unit disabled due to a faulty RESET button or EXTERNAL RESET input.

3.7 INTERNAL DIAGNOSTICS

The SSM-LE Series is supplied with a resident series of self-check diagnostic capabilities which monitor for correct operation of the SSM-LE Series both at power-up and continuously during operation. When a diagnostic test fails, the SSM-LE Series will enter the fault mode, transfer the OUTPUT relay contacts to the Fault position, and illuminate the DIAGNOSTIC indicator. A Power Failure will reset the Diagnostic fault state of the monitor (see Section 2.4). Due to the nature of these hardware/firmware failures, other fault indicators that may be concurrently displayed with the DIAGNOSTIC indicator may not be valid.

3.8 REAL TIME CLOCK / CALENDAR

A real time clock is provided on the SSM-LE series Signal Monitor to identify each event occurrence with the time of day and date. This information is displayed and stored along with the event status when the monitor is triggered by an event condition. The real time clock is backed-up by a long life lithium energy cell and thus maintains accurate timekeeping even during AC+ interruptions. This accuracy should remain within approximately ± 3 minutes per month.

The date and month are automatically adjusted for leap years. Daylight Savings Time adjustments are made to the time of day on the Sunday specified by the start and end DLS parameters. Daylight Savings Time parameters can be made using the EDI *ECom* software (see SET OPTIONS in the *(EDI ECom Software Operations Manual)*).

Setting the correct time of day and date is accomplished using the MODE and INC buttons on the front panel (see Section 6.5.4) or by using the SET TIME command using the EDI *ECom* software.

3.9 DISPLAY LED TEST

The monitor will illuminate all front panel LED and LCD indicators for 500ms when a Reset command is issued by the front panel RESET button or EXTERNAL RESET input. This function provides a means to check the operation of all front panel indicators.

3.10 RECURRENT PULSE DETECTION

This error detection function supplements the normal Conflict, Dual Indication, and Red Fail monitoring algorithms for sensing faults which are intermittent or pulsing in nature. The RMS-Engine is designed to filter out short term transients commonly found on the electrical service and provide noise immunity against false signal detections. The Recurrent Pulse detection function is designed to respond to fault conditions which are intermittent in nature and do not meet the continuous timing requirements of the normal detection algorithms, yet

may still produce improper signal displays. These input conditions are differentiated by their longer time constant and fault response times.

The figure below shows a simple example of a Recurrent Conflict fault. Channel 2 Green is detected active due to a malfunction of the load switch which caused the output to “flicker” On for 100 ms approximately every 200 ms. Because normal Conflict detection requires a continuous fault of at least 350 ms typical, this event could go undetected. The Recurrent Pulse detection algorithm will process these pulses into one event and trigger a Conflict fault once the longer recurrent timing threshold is exceeded.

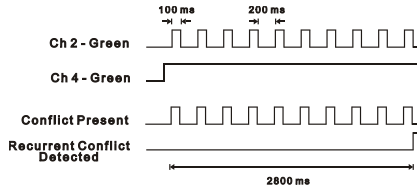

When triggered by a recurrent pulse fault condition, the SSM-LE Series will enter the fault mode, transfer the Output relay contacts to the Fault position, and display the appropriate CONFLICT, DUAL INDICATION, or RED FAIL status screen along with RP STATUS. The unit will remain in the fault mode until reset by the Reset button or the External Reset input. Fault response times will vary depending on the pulse width and frequency of the recurrent inputs, but typically range from 1000 ms minimum to 10 seconds maximum.

3.11 FLASHING YELLOW ARROW PROTECTED-PERMISSIVE MONITORING (FYA)

The SSM-LE Series is designed to monitor an intersection with up to four approaches using the four section Flashing Yellow Arrow (FYA) movement outlined by the NCHRP Research Project 3-54 on Protected/Permissive signal displays with Flashing Yellow Arrows. For monitoring purposes an FYA approach is logically defined as a four input “channel” consisting of the solid Red Arrow, solid Yellow Arrow, flashing Yellow Arrow (permissive), and solid Green Arrow (protected).

- WARNING -

EDI does not provide any guidelines, warrants, or recommendations for the use of protected/permissive left-turn phasing. The underlying assumption is that the traffic engineer has decided that this form of protected/permissive control is the most appropriate left-turn treatment, and all necessary considerations have been made. Until official rulemaking action by the MUTCD has occurred, the operation and functional parameters of the SSM-LE Series FYA and FYAc modes are subject to change.

Two cabinet configurations are supported depending on the number of load switches provided and the capabilities of the Controller Unit. A Flashing Yellow Arrow approach is actually monitored using two physical channels of the SSM-LE Series. In the basic FYA mode of the unit, one additional load switch is required for each FYA approach to be monitored. Thus a cabinet providing four vehicle phases, four pedestrian phases, and four FYA approaches would require sixteen load switches.

The compact FYAc mode requires the Controller Unit to remap the Yellow outputs of the pedestrian load switches to drive the protected Green Arrow signals of the FYA approaches. In this mode the cabinet can provide the four FYA approaches with an existing twelve position back panel. Configuration settings are described in Section 5.4.8.

3.11.1 BASIC FYA MODE

The cabinet must be wired such that for each FYA approach, the solid Green protected Arrow is driven by a load switch monitored on channels 1, 3, 5, and 7. The associated solid Red Arrow, solid Yellow Arrow, and flashing Yellow Arrow (FYA Overlap phase) must be driven by a load switch monitored on channels 9, 10, 11, 12 respectively. The SSM-LE Series associates channel 1 with 9, channel 3 with 10, channel 5 with 11, and channel 7 with 12 when FYA monitoring is enabled for that respective approach.

If a channel pair is enabled for FYA operation, the SSM-LE Series will monitor the FYA logical channel pair for the following fault conditions:

- a. Conflict
 - i. Channel conflicts are detected based on the Permissive programming jumpers on the Program Card for each channel. This operation remains unchanged from normal Nema operation.
- b. Red Fail
 - i. A Red Fail fault will occur if the solid Red Arrow AND solid Yellow Arrow AND flashing Yellow Arrow AND solid Green Arrow all remain inactive for the Red Fail fault response time. The fault icon (▼) will be displayed for both channels of the pair. The Red and Yellow inputs for channels 1, 3, 5, 7 do not affect the Red Fail condition for the FYA channels 9, 10, 11, 12.
- c. Dual Indication
 - i. A Dual Indication fault will occur if any two or more of the solid Red Arrow, solid Yellow Arrow, flashing Yellow Arrow, or solid Green Arrow signal combinations are active simultaneously for the Dual Indication fault response time. The fault icon (▼) will be displayed for the FYA channel 9, 10, 11, 12. The fault icon (▼) will also be displayed for the solid Green Arrow channel 1, 3, 5, 7 IF the solid Green Arrow was active.
 - ii. If the Dual Indication function (SSM) is enabled for the solid Green Arrow channels (1, 3, 5, 7) then a Dual Indication fault will occur if any two or more of the Red, Yellow, or solid Green Arrow inputs (1, 3, 5, 7) are active simultaneously for the Dual Indication fault response time.
- d. Clearance
 - i. A Clearance fault will be detected if the channel pair sequences from the solid Green Arrow (1, 3, 5, 7) to the solid Red Arrow (9, 10, 11, 12)

without a minimum clearance time on the solid Yellow Arrow (9, 10, 11, 12). The fault icon (▼) will be displayed for the FYA channel (9, 10, 11, 12).

- ii. A Clearance fault will be detected if the FYA channel sequences from the flashing Yellow Arrow (9, 10, 11, 12) to the solid Red Arrow (9, 10, 11, 12) without a minimum clearance time on the solid Yellow Arrow (9, 10, 11, 12). The fault icon (▼) will be displayed for the FYA channel (9, 10, 11, 12).
- iii. If the Clearance function (SSM) is enabled for the solid Green Arrow channels (1, 3, 5, 7) then a Clearance fault will be detected if the Green Arrow (1, 3, 5, 7) channel sequences from the solid Green Arrow (1, 3, 5, 7) to the solid Red Arrow (1, 3, 5, 7) without a minimum clearance time on the solid Yellow Arrow (1, 3, 5, 7). The fault icon (▼) will be displayed for the solid Green Arrow channel (1, 3, 5, 7).

3.11.2 COMPACT FYAC MODE

The cabinet must be wired such that for each FYA approach, the solid Green protected Arrow is driven by a load switch monitored on channels 9, 10, 11, and 12. The associated solid Red Arrow, solid Yellow Arrow, and flashing Yellow Arrow (FYA Overlap phase) must be driven by a load switch monitored on channels 1, 3, 5, and 7 respectively. The SSM-LE Series associates channel 1 with 9, channel 3 with 10, channel 5 with 11, and channel 7 with 12, when FYA monitoring is enabled for that respective approach.

Note: Using the Compact FYAc mode allows a standard twelve position load bay to provide the necessary signals without the addition of load switches for the FYA approaches. This mode requires that the Controller Unit be capable of remapping the Protected Green Arrow signal driver to the channel 9, 10, 11, and 12 Yellow load switch inputs. The cabinet must be (re)wired such that the outputs of the Ped Yellow load switches are monitored by channels 9, 10, 11, and 12 Green.

If a channel pair is enabled for FYAc operation, the SSM-LE Series will monitor the FYA logical channel pair for the following fault conditions:

- a. Conflict
 - i. Channel conflicts are detected based on the Permissive programming jumpers on the Program Card for each channel. This operation remains unchanged from normal Nema operation.
- b. Red Fail
 - i. A Red Fail fault will occur if the solid Red Arrow AND solid Yellow Arrow AND flashing Yellow Arrow AND solid Green Arrow all remain inactive for the Red Fail fault response time. The fault icon (▼) will be displayed for both channels of the pair. The Red and Yellow inputs for channels 9, 10, 11, 12 do not affect the Red Fail condition for the FYAc channels 1, 3, 5, 7.
- c. Dual Indication
 - i. A Dual Indication fault will occur if any two or more of the solid Red Arrow, solid Yellow Arrow, flashing Yellow Arrow, or solid Green Arrow signal combinations are active simultaneously for the Dual Indication fault response time. The fault icon (▼) will be displayed for the FYAc channel 1, 3, 5, 7. The fault icon (▼) will also be displayed for the solid Green Arrow channel (9, 10, 11, 12) IF the solid Green Arrow was active.
 - ii. If the Dual Indication function (SSM) is enabled for the solid Green Arrow channels (9, 10, 11, 12) then a Dual Indication fault will occur if any two or more of the Red, Yellow, or solid Green Arrow inputs (9, 10, 11, 12) are active simultaneously for the Dual Indication fault response time.
- d. Clearance

- i. A Clearance fault will be detected if the FYAc channel pair sequences from the solid Green Arrow (9, 10, 11, 12) to the solid Red Arrow (1, 3, 5, 7) without a minimum clearance time on the solid Yellow Arrow (1, 3, 5, 7). The fault icon (▼) will be displayed for the FYAc channel (1, 3, 5, 7).
- ii. A Clearance fault will be detected if the FYAc channel sequences from the flashing Yellow Arrow (1, 3, 5, 7) to the solid Red Arrow (1, 3, 5, 7) without a minimum clearance time on the solid Yellow Arrow (1, 3, 5, 7). The fault icon (▼) will be displayed for the FYAc channel (1, 3, 5, 7).
- iii. If the Clearance function (SSM) is enabled a Clearance fault will be detected if the Green Arrow (9, 10, 11, 12) channel sequences from the solid Green Arrow (9, 10, 11, 12) to the Red (9, 10, 11, 12) without a minimum clearance time on the Yellow (9, 10, 11, 12). The fault icon (▼) will be displayed for the solid Green Arrow channel (9, 10, 11, 12).

3.11.3 FYA CHANNEL ASSIGNMENT DIAGRAMS

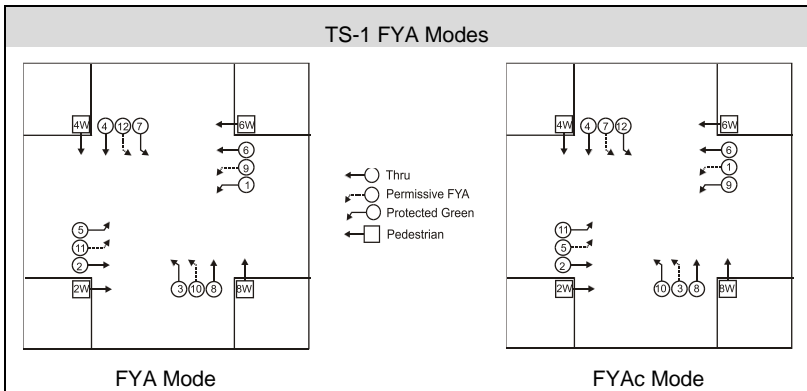

Section 4 ECcom Interface

4.1 EDI ECCOM MONITOR REPORTS

The EDI *ECcom* software package (**Version 3.6.8 or greater is required**) interfaces a Computer or System to the SSM-LE Series. The *ECcom* program will display the Status (S), Previous Fault (PF) event log, AC Line (AC) event log, Manual Reset (MR) event log, Configuration (CF) event log, and Signal Sequence logs. All events are time stamped with the time and date of the event.

Operation of the *ECcom* software package is described in ***EDI ECcom Software Operations Manual*** and will not be covered in this manual. The EDI *ECcom* software is available at no charge from the EDI web site at www.EDITraffic.com.

4.1.1 GENERAL DATA

Monitor ID#: a four digit (0000-9999) ID number may be assigned to the monitor.

Monitor Name: a thirty character name may be assigned to the monitor.

Time and Date: each event is marked with the time and date of occurrence.

Event Number: identifies the record number in the log. Event #1 is the most recent event.

4.1.2 CURRENT STATUS (S)

Fault Type: the fault type description.

Field Status: the current or latched RYGW field status and RMS voltages.

Cabinet Temperature: the current or latched temperature if the monitor.

AC Line Voltage: the current or latched AC Line voltage and frequency.

Control Input Status: the current or latched state and RMS voltage of the Red Enable input.

4.1.3 PREVIOUS FAULT (PF) EVENT LOG

Fault Type: the fault type description.

Field Status: the latched field status, RMS voltages, and fault channel status at the time of the fault.

Cabinet Temperature: the latched temperature at the time of the fault.

AC Line Voltage: the AC Line voltage and frequency at the time of the fault.

Control Input Status: the latched state and RMS voltage of the Red Enable input.

4.1.4 AC LINE (AC) EVENT LOG

Event Type: describes the type of AC Line event that occurred.

Power-up: AC on, monitor performed a cold start

Brown-out: AC Line < drop-out level

Restore: AC restored from AC brown-out or AC interruption, no cold start

AC Line Voltage: the AC Line voltage at the time of the event.

4.1.5 MANUAL RESET (MR) EVENT LOG

The monitor was reset from a fault by the front panel Reset button or External Reset input or non-latched fault clear.

4.1.6 CONFIGURATION (CF) EVENT LOG

Program Card Matrix: the permissive programming for each channel

SSM Enable Switches: the switch programming for each channel

Option Switches: GY Enable, LEDguard, WD Enable, Walk Disable, CVM Latch Enable, 24V Latch Enable, CVM Log Disable

Control Inputs: 24V Inhibit

Configuration Check Value: the value of the 16 bit Check Value for the reported configuration

4.1.7 SIGNAL SEQUENCE EVENT LOG

The Signal Sequence event log graphically displays all signal states and Red Enable state for up to 30 seconds prior to the SSM-LE Series fault trigger for the most recent five (5) Previous Fault (PF) events.

4.2 ETHERNET LAN PORT

The optional Ethernet port must be configured with specific network parameters such as an IP address, Subnet Mask, and Gateway address. The network port parameters are set or changed using the EDI *ECcom* Signal Monitor Communications software. See the "**EDI ECcom Software Operations Manual**" ETHERNET LAN SETTINGS Section 3.2.1.2 for details.

Section 5 Installation

5.1 PERMISSIVE CHANNEL PROGRAMMING

The SSM-LE Series Program Card contains a group of soldered wire jumper holes to set the permissive or compatible channel configuration. This programming is determined by the intersection layout and phase assignments. The card is initially supplied with 66 empty wire jumper hole pairs. This initial programming sets all channels to conflict with all other channels. To program a compatible channel pair, solder a wire jumper into the appropriate location for that channel pair as marked on the Program Card. **Make sure that any jumper leads do not make contact with any other jumper lead on the card or the monitor chassis when the Programming Card is inserted into the unit.**

Example: If channel 2 Green and Yellow is **PERMISSIVE** with channel 6 Green and Yellow, solder a jumper wire into the jumper pair labeled "2-6".

If the Program Card is absent or not seated properly in the edge connector, the SSM-LE Series will enter the fault mode, transfer the OUTPUT relay contacts to the Fault position, and display the PROGRAM CARD status screen. The SSM-LE Series will remain in the fault mode until the Program Card is correctly seated and the SSM-LE Series is reset by the RESET button or the EXTERNAL RESET input.

5.2 MINIMUM FLASH TIME PROGRAMMING

It is recommended that the Minimum Flash Time be programmed on the SSM-LE Series to facilitate an orderly start-up sequence of the Cabinet Assembly upon application or restoration of AC LINE power. The Minimum Flash Time should be long enough to ensure all cabinet components are initialized and ready before the SSM-LE Series transfers the OUTPUT relay and places the intersection into signal operation.

Programming of the front panel Minimum Flash DIP switches is in a binary encoded format:

MinFlash 8	MinFlash 4	MinFlash 2	MinFlash 1	Delay Period
Off	Off	Off	Off	4 seconds
Off	Off	Off	On	4 seconds
Off	Off	On	Off	4 seconds
Off	Off	On	On	4 seconds
Off	On	Off	Off	4 seconds
Off	On	Off	On	5 seconds
Off	On	On	Off	6 seconds
Off	On	On	On	7 seconds
On	Off	Off	Off	8 seconds
On	Off	Off	On	9 seconds
On	Off	On	Off	10 seconds
On	Off	On	On	11 seconds
On	On	Off	Off	12 seconds
On	On	Off	On	13 seconds
On	On	On	Off	14 seconds
On	On	On	On	15 seconds

5.3 SSM SWITCH PROGRAMMING

The SSM switches on the SSM-LE series Signal Monitor are labeled "1" to "12" ("6") corresponding to channels 1 through 12 (6), respectively. Positioning a switch in the ON position (to the right) enables a channel for Dual Indication **AND** Clearance Monitoring.

The channel SSM switch should be placed in the ON position when a channel has a Red, a Yellow, and a Green signal that turn both On and Off. The channel SSM switch should be placed in the OFF position when an unused Red field output terminal is connected to AC+ or for a channel that does not monitor the Yellow input such as an exclusive Ped channel.

5.4 UNIT OPTION PROGRAMMING

5.4.1 GY ENABLE OPTION

The GY-Dual Indication Monitoring function is **ENABLED** by setting the Option switch labeled GY ENABLE to the ON position. See Section 3.2.1.

5.4.2 LEDGUARD® ENABLE OPTION

The LEDguard® Monitoring function is **ENABLED** by setting Option switch labeled LEDguard to the ON state. See Section 1.4.1.

5.4.3 EXTERNAL WATCHDOG ENABLE OPTION

The External Watchdog Monitoring function is **ENABLED** by setting Option switch labeled WD ENABLE switch to the ON state. See Section 3.3.

5.4.4 WALK DISABLE OPTION

The Walk Disable function is **ENABLED** by setting the Option switch labeled WALK DISABLE to the ON state. See Section 2.2.2.

5.4.5 CONTROLLER VOLTAGE MONITOR (CVM) LATCH PROGRAMMING

The CVM Latch function is **ENABLED** by setting the Option switch labeled CVM LATCH to the ON position. See Section 2.3.2.1.

5.4.6 24VDC MONITOR LATCH PROGRAMMING

The 24V Latch function is **ENABLED** by setting the Option switch labeled 24V LATCH to the ON position. See Section 2.3.1.2.

5.4.7 LOG CVM FAULTS OPTION

The CVM Logging function is **DISABLED** by setting the Option switch labeled LOG CVM DISABLE to the ON state. See Section 2.3.2.2.

5.4.8 FLASHING YELLOW ARROW MONITOR

Flashing Yellow Arrow operation (see Section 3.11) requires first that the FYA mode be set by specifying the channel group that the Protected Green Arrows are assigned to:

	Protected Green Arrow Ch	Permissive R,Y,FY Arrow Ch
FYA Mode	1, 3, 5, 7	9, 10, 11, 12
FYAc Mode	9, 10, 11, 12	1, 3, 5, 7

The standard FYA Mode is selected by setting the Option switch labeled FYA MODE to the OFF position. The special FYAC (compact) Mode is selected by setting the Option switch labeled FYA MODE to the ON position.

Then for each FYA PPLT approach the corresponding Channel Pair Enable switch labeled FYA 1-9, FYA 3-10, FYA 5-11, or FYA 7-12 must be placed in the On position. If a channel pair is not enabled, both associated channels operate in a normal fashion.

Section 6 Front Panel Description

6.1 FAULT STATUS DISPLAY

The Fault Status Display is a wide temperature range Liquid Crystal Display (LCD) as shown. The SSM-LE series displays nine fault conditions in addition to the time and date that the event occurred. If the unit is operating normally without a fault condition present, the current time and date will be displayed.

CVM/WD	24V-1	24V-2
CONFLICT	DUAL INDICATION	
RED FAIL	PROGRAM CARD	
RP STATUS	CLEARANCE	
	PM	18:88 DATE
PREV FAIL	RE OFF	Rx Tx

6.1.1 CONFLICT INDICATOR

The CONFLICT indicator will be illuminated when a conflicting proceed signal fault is detected. The Field Status display will show all active field output signals at the time of the conflict. Dark solid arrows will be displayed below the channel number for each channel involved in the fault.

6.1.2 RED FAIL INDICATOR

The RED FAIL indicator will be illuminated when an absence of signal (Red Fail) is detected on a channel(s). The Field Output Status display will show all active field output signals at the time of the Red Fail fault. Dark solid arrows will be displayed below the channel number for each channel involved in the fault.

6.1.3 CVM / WD INDICATOR

The CVM/WD indicator will be illuminated when unit detects a CVM fault or External Watchdog fault. The Field Status display will show all active field output signals at the time of the CVM fault.

6.1.4 24V-1 INDICATOR

The 24V-1 indicator will be illuminated when unit detects a 24V-1 fault. The Field Status display will show all active field output signals at the time of the 24V-1 fault.

6.1.5 24V-2 INDICATOR

The 24V-2 indicator will be illuminated when unit detects a 24V-2 fault. The Field Status display will show all active field output signals at the time of the 24V-2 fault.

6.1.6 RP STATUS INDICATOR

The RP STATUS indicator will illuminate when the Recurrent Pulse detection function has triggered a Conflict, Dual Indication, or Red Fail fault. The Field Status Display will flash the channel input(s) that were detected with Recurrent Pulse status. See Section 3.10.

6.1.7 PROGRAM CARD INDICATOR

The PROGRAM CARD indicator will illuminate if the program card is absent or not seated properly in the edge connector. A RESET or EXTERNAL RESET is required after the program card is properly seated.

6.1.8 DUAL INDICATION INDICATOR

The DUAL INDICATION indicator will be illuminated when a Dual Indication fault is detected on a channel(s). The Field Status display will show all active field output signals at the time of the Dual Indication fault. Dark solid arrows will be displayed below the channel number for each channel involved in the fault.

6.1.9 CLEARANCE INDICATOR

The CLEARANCE indicator will be illuminated on the SSM-LE series Signal Monitor when no Yellow or a short (less than 2.7 seconds) Yellow signal is detected on a channel(s) during a Red to Green to Yellow to Red sequence. The Field Status display will show all active field output signals at the time of the Clearance fault. Dark solid arrows will be displayed below the channel number for each channel involved in the fault.

6.1.10 TIME AND DATE INDICATOR

The clock and calendar display will alternate between the time of day and the date. The time may be denoted by a "PM" indicator. The date will be denoted by the "DATE" indicator. If the unit is displaying fault information then the time and date will indicate when the fault occurred, otherwise, the current time of day and date will be displayed.

6.1.11 RE OFF INDICATOR

The RE OFF indicator will be displayed if the RED ENABLE input is not active. This indicates that Red Fail Monitoring, Dual Indication Monitoring, and Clearance Monitoring are disabled.

6.1.12 RX INDICATOR

The Rx indicator will be displayed when the EIA-232 or Ethernet port has correctly received a message.

6.1.13 TX INDICATOR

The Tx indicator will be displayed when the EIA-232 or Ethernet port has transmitted a message.

6.1.14 PREV FAIL INDICATOR

Previous fault event information can be displayed by using the MODE button to enter the Previous Fault Display Mode. See Section 6.5.1. The PREV FAIL indicator will be displayed along with the event number, fault status, field status, and time and date of the fault also shown.

6.2 FIELD STATUS DISPLAY

The Field Output Status Display(s) provide a Full Intersection view as shown. The SSM-LE series Signal Monitor displays exceed the minimum NEMA requirements by showing all four field output signals per channel. If the unit is operating normally without a fault condition present, the currently active field output signals will be displayed. Once triggered by a fault condition, the displays will retain the signals active at the time of the fault.

Dark solid arrows (▼) will be displayed below the channel number for each channel involved in the fault.

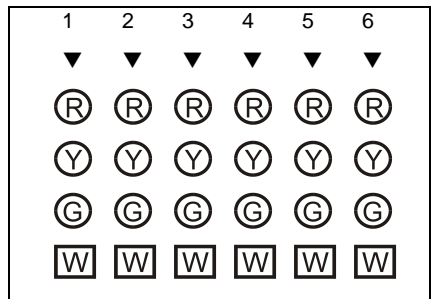

6.3 LED STATUS DISPLAY

6.3.1 POWER INDICATOR

The POWER LED indicator will flash at a rate of 2Hz when the AC+ line voltage goes below the drop-out level. It will illuminate steadily when the AC+ line voltage returns above the

brown-out restore level. The indicator will extinguish when the AC+ line voltage is less than 75 Vrms.

6.3.2 FAULT INDICATOR

The FAULT LED indicator will illuminate when the unit has been triggered by a fault condition and indicates that the Monitor has caused the Output relay contacts to transfer. The Fault Status Display and Field Output Status Display should be consulted for more detailed information about the failure.

6.3.3 DIAGNOSTIC INDICATOR

The DIAGNOSTIC LED indicator will illuminate when an internal monitor failure is detected. This indicator is used to inform the service technician of a monitor hardware and/or firmware failure. Due to the nature of these hardware/firmware failures, other fault indicators that may be concurrently displayed may not be valid for trouble shooting purposes.

6.4 BUTTONS

6.4.1 RESET BUTTON

Depressing the RESET button resets the SSM-LE series Signal Monitor after it has been triggered by a fault. The monitor remains in the reset mode only if the fault condition has been restored to normal. Depressing the RESET Button while the display is in the PF Data Log, AC Data Log, or Clock Set mode will only reset the display mode to the normal mode.

In the event of a monitor hardware or firmware fault (DIAGNOSTIC indicator is illuminated) the Reset button may not reset the monitor.

6.4.2 MODE BUTTON

Depressing the MODE button changes the mode of the front panel displays to display the Previous Fault Log information (PF Data Log mode), the AC Power Interruption and Restoration Log Information (AC Data Log mode), and allow the time of day and date to be modified (Clock Set mode). The Clock Set mode can only be entered when the Monitor is not in the fault mode.

6.4.3 INC BUTTON

If the unit is in the PF Data Log mode, depressing the INC button will cause the next Previous Fail event information to be displayed. Holding the INC button depressed will continuously scroll at a 2Hz rate until the button is released.

If the unit is in the AC Data Log mode, depressing the INC button will cause the next AC interrupt or restore event information to be displayed. Holding the INC Button depressed will continuously scroll at a 2Hz rate until the button is released.

If the unit is in the Clock Set mode, depressing the INC button will cause the currently addressed field of the clock to increment by one. Holding the INC button depressed will continuously scroll at a 2Hz rate until the button is released.

6.5 DISPLAY MODES

6.5.1 PREVIOUS FAULT DISPLAY MODE (PF DATA LOG)

The first closure of the MODE button advances the display mode to the PF Data Log mode. The RESET button may be used to return to the normal operation display format. The PREV FAIL indicator will be displayed along with the event number of the fault also shown. Each INC button closure will display the next previous failure event information. A total of 25 previous fail events can be displayed. Previous Failure #1 (PF 1) is the current or most

recent fault event logged. Previous Failure #25 is the oldest fault event logged. If the display indicates PF 0, the Previous Failure event log is empty.

6.5.2 AC DATA LOG DISPLAY MODE (AC DATA LOG)

The second closure of the MODE button advances the display mode to the AC Data Log mode. The RESET button may be used to return to the normal operation display format. In this mode each closure of the INC button will advance the Fault Status display to the next AC Data Log event information. A total of 40 power interruptions and restorations labeled "AC 1" to "AC 40" can be reviewed. The display will sequence the log event type (AC) followed by the event number (1:40) followed by On or Off followed by the time and date of the event. If the display indicates AC 0, the AC Data Log is empty.

6.5.3 CONFIGURATION DISPLAY MODE

The third closure of the MODE button advances the display mode to the Configuration display mode. The RESET button may be used to return to the normal operation display format. The PROGRAM CARD indicator will be illuminated. The Field Status display will present the compatible channel programming for each channel in a sequential fashion for each closure of the INC button. The Primary channel is indicated by the ▼ symbol on the Channel Status display. All Secondary channels programmed permissive (jumper installed) with the displayed primary channel will be indicated on the Channel Status display with their ⓐ and ⓑ and ⓐ icons illuminated. Pressing the NEXT button will increment the display to the next Primary channel.

These settings are read-only and require the Program Card jumpers to be changed.

After all channel permissives are displayed, the next closure of the INC button will display the SSM switch programming. Each channel with the SSM switch On will be denoted by a dark solid arrow (δ) and the Red, Yellow, Green, and Walk indicators illuminated. The CLEARANCE and DUAL INDICATION indicators will be illuminated. If all SSM switches are in the Off position or the Red Enable input is not active, the Fault Status display will show ΔOFF®, indicating that the Clearance and Dual Indication monitoring functions are disabled. Red Fail monitoring is also disabled by Red Enable input not active.

6.5.4 CLOCK SET DISPLAY MODE

The fourth closure of the MODE button advances the display mode to the Clock Set mode if the monitor is not currently in the fault mode. Each subsequent MODE button closure advances the Clock set display mode to the next field. The time and date fields are addressed in the following order: hours, minutes, month, date, year. The real time clock is set with the new time and date when the MODE button is pressed following the year entry. The RESET button may be used to return to the normal operation display format without modifying the time or date.

6.6 CLEARING THE DATA LOGS

Erasing the contents of the event data logs requires two deliberate steps to prevent inadvertent erasure of the logs. The first step is to depress and hold in both the MODE and INC buttons simultaneously followed by a momentary depression of the RESET button. The top LCD will flash the letters "CLr" to indicate it is in the clear data log mode and is waiting for the next step. Release the MODE and INC buttons. The final step to clear the data log is to depress and hold in the MODE button, then simultaneously depress the INC button and then release both buttons. The top LCD will return to alternately displaying the time and date. The RESET button can be depressed at any time to exit this mode without clearing the data log. The data log can also be cleared by using the CLEAR LOGS command in the EDI ECom software.

Section 7 Specifications

7.1 ELECTRICAL

7.1.1 POWER REQUIREMENTS

Operating Line Voltage	75 to 135 Vrms
Operating Line Frequency	60 \pm 3Hz
Power Consumption	10W (nominal)

7.1.2 AC VOLTAGE MONITORS

Nema Green Signal Inputs	
No Detect	less than 15 Vrms
Detect	greater than 25 Vrms
Nema Yellow Signal Inputs	
No Detect	less than 15 Vrms
Detect	greater than 25 Vrms
Nema Walk Signal Inputs	
No Detect	less than 15 Vrms
Detect	greater than 25 Vrms
Nema Red Signal Inputs	
No Detect	less than 50 Vrms
Detect	greater than 70 Vrms
<i>LEDguard</i> [®] Low Threshold Signal Inputs	
No Detect	less than 15 Vrms
Detect	greater than 25 Vrms
<i>LEDguard</i> [®] High Threshold Signal Inputs	
No Detect	less than 50 Vrms
Detect	greater than 70 Vrms
Red Enable Input	
No Detect	less than 70 Vrms
Detect	greater than 89 Vrms

7.1.3 POWER FAIL MONITOR

AC Line Input	
Dropout	less than 92 \pm 2 Vrms
Restore	greater than 96 \pm 2 Vrms

7.1.4 DC VOLTAGE MONITOR

+24V MONITOR I, +24V MONITOR II	
Fault	less than 18 Vdc
No Fault	greater than 22 Vdc

7.1.5 LOGIC INPUTS

Controller Voltage Monitor (CVM), External Reset, +24V Monitor Inhibit, and External Watchdog Input	
True (low)	less than 8 Vdc
False (high)	greater than 16 Vdc

7.2 MECHANICAL

Height	10.5 inches
Width	4.5 inches
Depth	8.5 inches

7.3 ENVIRONMENTAL

Storage Temperature Range	-45 to +85 °C
Operating Temperature Range	-34 to +74 °C

LCD Operating Temperature Range -34 to +74 °C
Humidity Range (non-condensing).....0 to 95% Relative

7.4 TIMING FUNCTIONS

Conflict

No Fault less than 200 msec
Fault greater than 450 msec
Typical 350 msec

Red Fail

No Fault less than 700 msec
Fault greater than 1000 msec
Typical 850 msec

Controller Voltage Monitor (CVM)

No Fault less than 125 msec
Fault greater than 175 msec
Typical 150 msec

+24Vdc Monitor

No Fault less than 125 msec
Fault greater than 175 msec
Typical 150 msec

Clearance Fail

No Fault greater than 2.8 second
Fault less than 2.6 second
Typical less than 2.7 second

Dual Indication

No Fault less than 200 msec
Fault greater than 500 msec
Typical 400 msec

Power Fail

Respond greater than 500 msec
No Response less than 450 msec
Typical 475 msec

Minimum Flash 4 to 15, ± 1 second

Start Delay 2.5 ± 0.5 second

Section 8 Wiring Assignments

8.1 SSM-12LE HARNESSING CONNECTORS

These Military Specification MIL-C-26482 connectors are interchangeable with 12 channel monitors as defined by NEMA Traffic Control Systems Specification TS1-1989 R2005, part 6. Connector MS-A will intermate with a MS 3116 22-55 SZ. Connector MS-B will intermate with a MS 3116 16-26 S.

8.1.1 SSM-12LE CONNECTOR MS-A PIN TERMINATIONS

Pin	Function	I/O
A	AC Line	[I]
B	Output Relay 1 Open (Stop Time, Closes when fault occurs)	[O]
C	Output Relay 2 Closed (FTR Drive, Opens when fault occurs)	[O]
D	Channel 12 Green	[I]
E	Channel 11 Green	[I]
F	Channel 10 Green	[I]
G	Channel 9 Green	[I]
H	Channel 8 Green	[I]
J	Channel 7 Green	[I]
K	Channel 6 Green	[I]
L	Channel 5 Green	[I]
M	Channel 4 Green	[I]
N	Channel 3 Green	[I]
P	Channel 2 Green	[I]
R	Channel 1 Green	[I]
S	+24 Monitor I	[I]
T	Logic Ground	[I]
U	Earth Ground	[I]
V	AC Neutral	[I]
W	Output Relay 1 Common (Stop Time)	[I]
X	Output Relay 2 Common (FTR Drive)	[I]
Y	Channel 12 Yellow	[I]
Z	Channel 11 Yellow	[I]
a	Channel 10 Walk	[I]
b	Channel 10 Yellow	[I]
c	Channel 9 Yellow	[I]
d	Channel 8 Yellow	[I]
e	Channel 7 Yellow	[I]
f	Channel 6 Yellow	[I]
g	Channel 5 Yellow	[I]
h	Channel 3 Yellow	[I]
i	Channel 3 Walk	[I]
j	Channel 2 Yellow	[I]

Pin	Function	I/O
k	Channel 1 Yellow	[I]
m	Controller Voltage Monitor	[I]
n	+24V Monitor Inhibit	[I]
p	Output Relay 1 Closed (Stop Time, Opens when fault occurs)	[O]
q	Output Relay 2 Open (FTR Drive, Closes when fault occurs)	[O]
r	Channel 12 Walk	[I]
s	Channel 11 Walk	[I]
t	Channel 9 Walk	[I]
u	Channel 8 Walk	[I]
v	Channel 7 Walk	[I]
w	Channel 5 Walk	[I]
x	Channel 4 Yellow	[I]
y	Channel 2 Walk	[I]
z	Channel 1 Walk	[I]
AA	Spare 1	[-]
BB	Reset	[I]
CC	Cabinet Interlock A	[I]
DD	Cabinet Interlock B	[O]
EE	Channel 6 Walk	[I]
FF	Channel 4 Walk	[I]
GG	Spare 2	[-]
HH	Spare 3	[-]

8.1.2 SSM-12LE CONNECTOR MS-B PIN TERMINATIONS

Pin	Function	I/O
A	AC Line II	[I]
B	Start-Delay Relay Common	[I]
C	Start-Delay Relay Open (Closes during Start Delay period)	[O]
D	Channel 12 Red	[I]
E	Channel 11 Red	[I]
F	Channel 9 Red	[I]
G	Channel 8 Red	[I]
H	Channel 7 Red	[I]
J	Channel 6 Red	[I]
K	Channel 5 Red	[I]
L	Channel 4 Red	[I]
M	Channel 2 Red	[I]
N	Channel 1 Red	[I]
P	Spare 1	[-]
R	+24V Monitor II	[I]
S	External Watchdog (Spare 2)	[-]
T	Spare 3	[-]

Pin	Function	I/O
U	Start-Delay Relay Closed (Open during Start Delay period)	[O]
V	Channel 10 Red	[I]
W	Spare 4	[-]
X	Spare 5	[-]
Y	Spare 6	[-]
Z	Channel 3 Red	[I]
a	Red Enable	[I]
b	Spare 7	[-]
c	Spare 8	[-]

8.2 SSM-6LE HARNESSING CONNECTOR

This Military Specification MIL-C-26482 connector is interchangeable with 6 channel monitors as defined by NEMA Traffic Control Systems Specification TS1-1989 R2005, part 6. Connector MS-A will intermate with a MS 3116 22-55 SY.

8.2.1 SSM-6LE CONNECTOR MS-A PIN TERMINATIONS

Pin	Function	I/O
A	AC Line I	[I]
B	AC Line II	[I]
C	Output Relay 1 Open (Stop Time, Closes when fault occurs)	[O]
D	Output Relay 2 Closed (FTR Drive, Opens when fault occurs)	[O]
E	Start-Delay Relay Open (Closes during Start Delay period)	[O]
F	Channel 6 Green	[I]
G	Channel 6 Red	[I]
H	Channel 5 Green	[I]
J	Channel 4 Green	[I]
K	Channel 4 Red	[I]
L	Channel 3 Green	[I]
M	Channel 2 Green	[I]
N	Channel 2 Red	[I]
P	Channel 1 Green	[I]
R	Red Enable	[I]
S	+24V Monitor I	[I]
T	Logic Ground	[-]
U	Chassis Ground	[-]
V	AC Neutral	[-]
W	Cabinet Interlock B	[-]
X	Output Relay 1 Common (Stop Time)	[I]
Y	Output Relay 2 Common (FTR Drive)	[I]
Z	Output Relay 2 Open	[O]

Pin	Function	I/O
	(Closes when fault occurs)	
a	Start Delay Relay Common	[I]
b	Channel 6 Yellow	[I]
c	Channel 5 Yellow	[I]
d	Channel 5 Red	[I]
e	Channel 4 Yellow	[I]
f	Channel 3 Yellow	[I]
g	Channel 3 Red	[I]
h	Channel 2 Yellow	[I]
i	Channel 1 Yellow	[I]
j	Channel 1 Red	[I]
k	+24V Monitor II	[I]
m	Controller Voltage Monitor	[I]
n	+24V Monitor Inhibit	[I]
p	Cabinet Interlock A	[-]
q	Spare 1	[-]
r	Output Relay 1 Closed (Stop Time, Opens when fault occurs)	[O]
s	Start-Delay Relay Closed (Opens during Start Delay period)	[O]
t	Channel 6 Walk	[I]
u	Channel 5 Walk	[I]
v	Channel 4 Walk	[I]
w	Channel 3 Walk	[I]
x	Channel 2 Walk	[I]
y	Channel 1 Walk	[I]
z	Reset	[I]
AA	Spare 2	[-]
BB	Spare 3	[-]
CC	Spare 4	[-]
DD	Spare 5	[-]
EE	Spare 6	[-]
FF	Spare 7	[-]
GG	Spare 8	[-]
HH	Spare 9	[-]

8.3 EIA-232 CONNECTOR

Pin	Function	I/O
1	DCD	O
2	Tx DATA	O
3	Rx DATA	I
4	DTR	I
5	GROUND	-
6	DSR	O

Pin	Function	I/O
7	CTS	I
8	RTS	O
9	NC	-

If the monitor DTR Enable option is selected (See **EDI ECom Software Operations Manual**) the Data Terminal Ready (DTR) input must be in the high state (>4 Vdc) for the monitor EIA-232 port (DCE device) to be active. DCD, DSR, CTS, and RTS are provided for compatibility with Data Terminal Equipment (DTE device) control signals. If required by the Data Terminal Equipment device (Personal Computer), DCD may be driven high by inserting internal jumper E8. If the Data Terminal Equipment device uses CTS instead of DTR to control data flow, insert internal jumper E9 and remove internal jumper E7.

8.3.1 EIA-232 CABLE TO A PC

A typical cable assembly for a DB-9 connector on the PC is a straight through connection as follows:

<u>PC DB-9</u>		<u>Monitor DB-9</u>
RX pin 2	connect to	TX pin 2
TX pin 3	connect to	RX pin 3
DTR pin 4	connect to	DTR pin 4 (optional)
GND pin 5	connect to	GND pin 5

A typical cable assembly for a DB-25 connector on the PC would be as follows:

<u>PC DB-25</u>		<u>Monitor DB-9</u>
RX pin 3	connect to	TX pin 2
TX pin 2	connect to	RX pin 3
DTR pin 20	connect to	DTR pin 4 (optional)
GND pin 7	connect to	GND pin 5

8.4 ETHERNET LAN PORT

The Ethernet port must be configured with specific network parameters such as an IP address and Subnet Mask. The network port parameters are set or changed using the EDI ECom Signal Monitor Communications software. See the "**EDI ECom Software Operations Manual**" for details.

The factory default network settings are: IP Address = 192.168.1.100 and Subnet Mask = 255.255.255.0

8.4.1 ETHERNET LAN CABLE

If the connection is from the monitor to a switch or hub, a standard 8-pin RJ-45 connector LAN cable is needed. If the connection is from the monitor directly to a network adaptor (PC), a cross-over or patch cable is needed.