

Eberle Design Inc.

---

- 210E Series -  
Signal Monitor  
Training Seminar

---

EBERLE DESIGN INC.



0400 © Copyright EDI 2000

Eberle Design Inc.  
3819 East La Salle Street  
Phoenix, AZ 85040

|           |                        |
|-----------|------------------------|
| Telephone | 480-968-6407           |
| Fax       | 602-437-1996           |
| e-mail    | support@editraffic.com |
| web site  | www.editraffic.com     |

|                |                        |
|----------------|------------------------|
| Scott Evans    | Engineering Manager    |
| Noel Soriano   | Senior Design Engineer |
| Jon Muilenberg | National Sales Manager |

## Introduction

---

- ◆ Goal: Better Understand Monitor & Cabinet System Operation
- ◆ Topics
  - » General Signal Monitor Concepts
  - » 210E Features
  - » 210E Installation

Not all symptoms of cabinet equipment malfunctions lead to the most obvious remedy.

These topics are intended to give an overall view of the important concepts needed to understand the operation of a basic signal monitor and in particular the EDI 210E series signal monitor.

These skills are needed to quickly and effectively trouble shoot a malfunctioning intersection.

## Motivation

---

- ◆ Signal Monitors help ensure proper intersection operation
- ◆ Signal Monitors help trouble shoot malfunctioning equipment
- ◆ Liability risks have increased dramatically
- ◆ Costs of trouble shooting & repairing malfunctions has increased

The purpose of the signal monitor is to detect and respond to improper and potentially dangerous operating conditions resulting from the malfunction of the cabinet equipment, field wiring, or signal heads.

The diagnostic tools built into modern signal monitors can be used to quickly diagnose the cause of the malfunction and document the details. The signal monitor should be considered a tool just as a voltmeter or laptop computer would.

### **STOP - LOOK - THINK - ACT**

In order to help increase safety levels and reduce liability risks, the first defense is to ensure that any malfunction is properly detected and responded to. A working and correctly installed signal monitor provides this function.

The sooner an intersection is returned to operation the better, both from a safety perspective and moving traffic perspective. Maintenance budgets are getting tighter putting more emphasis on quick and effective repair.

## 210E series Overview

---

- ◆ Exceeds all requirements of Caltrans 1989
- ◆ Adds enhanced monitoring functions
- ◆ RMS-Engine™ coprocessor calculates true RMS voltages
- ◆ 2010ECL & 210ECL models include event logging and full intersection display.
  - » Status and Configuration
  - » Five event logging functions
  - » Signal Sequence history log

The 210E provides all of the same functions that a Caltrans 210 Conflict Monitor provides. Enhancements have been made to provide a broader fault coverage as well as more diagnostic capabilities.

Red Monitoring, Dual Indication Monitoring, Sequence Monitoring are functions added to extend fault coverage. The Red Interface cable on the front panel is used to bring in the Red signals and additional control inputs.

A second high speed uP (RMS-Engine) calculates true RMS voltages using over-sampled data from an on-board A/D converter.

The EDI *ECcom* software interfaces a 2010ECL or 210ECL to a laptop computer running Microsoft Windows 95-98.

Event logging is a tool for trouble shooting and record keeping. Event logs are Previous Failures, AC Line events, Reset events, and Configuration change events. A separate log is presented that organizes the four types of records in chronological order. The Fault Signal Sequence display shows signal states leading up to the current fault.

## Flash Operation

- ◆ The monitor *Output Relay* controls the mercury contactor and flash transfer relays. Flash mode energizes these relays.
- ◆ The *Stop Time Output* halts the CU timing.
- ◆ Optional Minimum Flash of 6 seconds following AC Line interruption or brownout restore

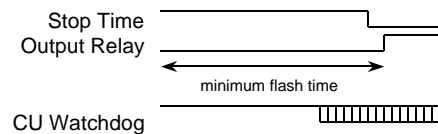

The monitor Output Relay has the ultimate control of flashing operation. This relay provides the AC Line voltage to the mercury contactor and flash transfer relays when flashing operation is desired. It may be wired in parallel with the Police Flash switch.

The Stop Time output is used to hold the CU timing state at the time of a fault.

The Minimum Flash period is designed to provide 6 seconds of hardware flash following a power interruption, or low voltage condition. This provides a flashing transition from dark signals to the startup phase. It also holds off signal operation until the 2070 CU can boot-up and drive the load switches.

## Field Input Thresholds

### ◆ The 210E is a voltage sensing device

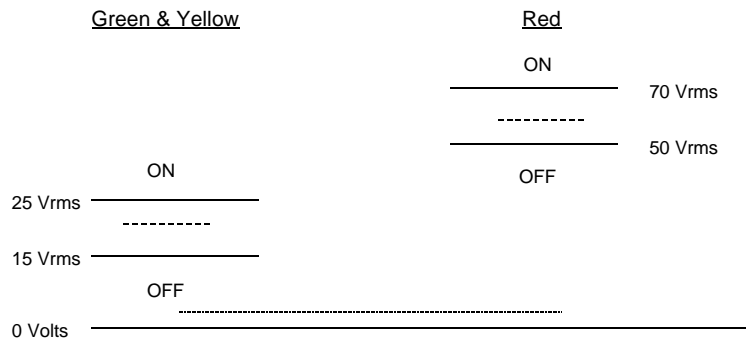

Signal monitors are voltage sensing devices. The thresholds for sensing a signal as ON or OFF are set differently for Green and Yellow colors than Red. This is due to the nature of the fault monitoring for each color set.

For Conflicts the monitor should sense a signal ON when the bulb first becomes visible as the voltage is increased. The Conflict fault exists when a signal is On when it should be Off. For Red Fail, the monitor should sense a signal OFF when the bulb first starts to become not visible as the voltage is decreased. The Red Fail fault exists when a signal is Off when it should be On.

A monitor shall sense a signal as OFF when its RMS voltage is below the lower threshold (15v / 50v). A monitor shall sense a signal as ON when its RMS voltage is above the upper threshold (25v / 70v). A monitor may or may not sense a signal as ON when the voltage lies between the upper and lower thresholds.

## 210E Faults

---

### ◆ Conflict

- » Detects two or more active *proceed* channels which are programmed to be incompatible.
- » Timing: 200 ms to 500 ms, 350 ms typical

### ◆ Red Fail

- » Detects a channel which has no active inputs (R or Y or G).
- » Timing: 700 to 1000 ms, 850 ms typical
- » Enabled by Red Enable input
- » Disabled by Special Function inputs

### Conflict

The Conflict function detects two or more active *proceed* channels which are programmed to be incompatible.

A proceed color is a Green or Yellow. Conflicts are usually caused by a load switch output shorted ON, a short circuit in the field, or loss of load in the field. Improper programming of the CU or the monitor Program Card can also cause conflicts.

### Red Fail

The monitor senses voltage across the load. A “dark” signal head may have voltage present at the monitor inputs due to other causes. In most cases a Red Fail is caused by the CU not turning on a load switch, a faulty load switch not turning on an output, or improper programming.

A loss of load will NOT cause a Red Fail. Load switch leakage current will (usually) provide enough voltage across the load that the monitor will sense an active signal. This usually results in a Conflict or Dual Indication fault.

Red Fail also helps ensure that “harness” connections are good.

## 210E Faults

---

- ◆ **CU Watchdog Monitor (WDT ERROR)**
  - » Toggling logic input to indicate CU software is operating
  - » Timing: 1500 ms typical, latching
  - » Power-up will reset the fault but not the LED
- ◆ **24 Volt Monitor (VDC FAILED)**
  - » Monitors the 24 Vdc power supply
  - » Voltage: <18 Vdc = fault, >22 Vdc = operate
  - » Timing: 400 ms typical, latching

### CU Watchdog Monitor (WDT ERROR)

This logic level signal is toggled by the CU to indicate proper operation in the CU. It is not monitored at low voltage (<98) since the CU may be forced into reset at low AC Line levels by its own detection circuit.

If the LED is ON but the cabinet is operating, it indicates a WDT ERROR occurred and was reset by a loss of power. This “non-latching” operation may be modified by the SEL1 jumper option.

### 24 Volt Monitor (VDC FAILED)

This input monitors the 24V power supply for proper operation. Proper operation is defined as greater than 22 Vdc. Improper operation is less than 18 Vdc.

## 210E Faults

---

### ◆ Dual Indication Fault

- » Detects more than one active input (color) on a channel (GY + GR + YR + GYR)
- » Can *anticipate* Conflict malfunctions before they are displayed on the signals
- » Enabled by Red Enable input and SSM switches (per channel)

### Dual Indication Fail

This monitoring function will detect more than one input (color) of a channel active at the same time. This may be caused by a load switch output stuck ON, a short circuit in the field, or a loss of load (burned out bulbs or open field wire).

If a Green (or Yellow) signal stays ON due to short circuit or load switch failure it will be detected as a Dual Indication fault when the Yellow (or Red) signal on that channel activates. This will put the intersection to flash before the next conflicting phase is active, preventing a conflict display in the field.

Similarly, a loss of the Red load will be detected when that channel cycles to Green.

This function also works in conjunction with Red Fail to ensure that all channels are being monitored (e.g. harness problem).

Timing: 200 ms to 500 ms, 400 ms typical.

## 210E Faults

---

### ◆ Sequence Fail

- » Measures the Yellow Change interval for an MUTCD 3 second minimum
- » Timing: 2.7 seconds typical, programmable from 2.7 to 4.1 seconds
- » Enabled by Red Enable input and SSM switches (per channel)

The Minimum Yellow Clearance monitor ensures that a Green to Yellow to Red sequence has an MUTCD three second Yellow clearance interval. It is measured on vehicle channels which have a true Yellow signal.

To disable this function for a channel which does not have a true Yellow signal, the SSM switch for that channel should be OFF, or the Yellow Disable jumper should be in place. This would be the case for pedestrian and protected-permissive left turn channels for example.

This problem is usually related to a controller malfunction, preemption problem, or programming error. The response time must be set for the shortest yellow interval of all phases.

ECcom will report this fault with a *short yellow* or *skipped yellow* status.

## 210E Faults

---

- ◆ Diagnostic Fail
  - » Internal MPU watchdog circuit
  - » ROM, RAM, or EEPROM failure
  - » Internal power supply failure
  - » Internal diagnostic failure
- ◆ Program Card Ajar (PCA)
  - » Indicates the Program card is not in place or inserted properly
  - » Flashing LED indicates Configuration Change fault

### Diagnostic Fail

The 210E has many internal diagnostic tests that ensure proper operation of the monitor. **THIS DOES NOT TAKE THE PLACE OF REGULAR MONITOR TESTING!** If the Diagnostic Fail LED has illuminated, other LEDs may not be valid. The unit should be tested before returning to service.

### Program Card Ajar

If the Program Card is removed, the unit will go to the fault mode and illuminate the PCA Led. A manual Reset is required once the Program Card is inserted properly.

If the PCA Led is flashing, a *Configuration Change* fault has been detected.

## 210E Faults

---

- ◆ Configuration Change Fault
  - » Detects changes in the conflict matrix, switch settings, jumpers, & WD Enable switch
  - » Power-up, reset, and run-time check
  - » Jumper selectable (SEL3)
  - » Configuration CRC value is displayed by ECcom (210ECL)

The unit maintains an internally calculated CRC value of the current configuration settings. These settings include the permissive diode matrix, SSM switches, Yellow Disable switches, Option switches, SEL1, SEL2, and SEL3 jumpers, and the Watchdog Enable switch. On power-up, reset, and periodically during operation, the unit will compare the current configuration settings with the previously stored value. If the settings have changed, the unit will automatically log the new setting.

When the Configuration Change Fault option is selected, any change in the configuration parameters will cause the unit to enter the fault mode. To indicate this fault mode the PCA indicator will flash at a 4 Hz rate. Depressing the Reset button for 5 full seconds will clear this fault and log the new configuration parameters.

If the Configuration Change Fault select jumper is not installed, the unit will not set the fault mode but will still log the configuration change.

## 210E Faults

### ◆ Recurrent Pulse Detection

- » Detects intermittent or pulsing signal conditions which may not meet the requirements of typical continuous fault detection algorithms.
- » The RP DETECT LED will illuminate with Conflict or Red Fail or Dual Indication LED.

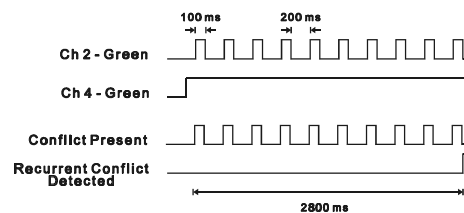

The Recurrent Pulse detection (RP DETECT) function is designed to respond to fault conditions which are intermittent in nature and do not meet the continuous timing requirements of the normal detection algorithms, yet may still produce improper signal displays. These input conditions are differentiated by their longer time constant and fault response times.

The figure shows an example of a recurrent Conflict fault. Channel 2 Green is detected active due to a malfunction of the load switch which caused the output to “flicker” On for 100 ms approximately every 200 ms. Since normal Conflict detection requires a continuous fault of at least 350 ms typical, this event could go undetected. The Recurrent Pulse detection algorithm will combine these pulses into one event and trigger a Conflict fault once the longer recurrent timing threshold is exceeded.

# Load Switch Leakage Current

## ◆ Load Switch Block Diagram

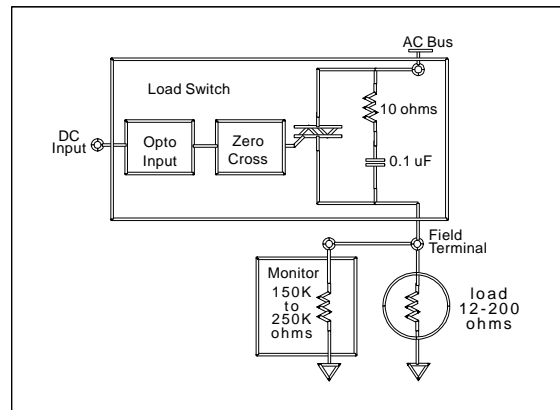

Because a monitor only senses voltage across the signal load and not current, the effect of driving the load with a solid state Load Switch can produce unexpected results when a component malfunctions. The effect of leakage current is important to understand for trouble-shooting reasons and proper system design especially as new signal technologies become available.

The load switch has a DC input which is optically isolated from the AC Line voltage. When a voltage less than 6 Vdc is applied to the input the input circuit will activate. The zero-cross circuit synchronizes the turn-on to the AC Line. The triac device will only conduct in one half cycle periods.

The triac needs to be protected against transient voltages by the resistor / capacitor snubber circuit shown. Off-state leakage current does not come through the triac switch, but through this snubber.

## Load Switch Leakage Current

- ◆ AC impedance of snubber capacitor
  - »  $1/(2\pi fC) = 26 \text{ Kohms}$  ( $C=0.1 \text{ uf}$ ,  $f=60 \text{ hz}$ )
- ◆ Leakage current approximation
  - »  $120\text{v} / 26\text{K} = 5 \text{ ma}$
  - »  $V_m = (99 / 26.9\text{K}) * 120\text{v} = 0.5 \text{ Vac}$

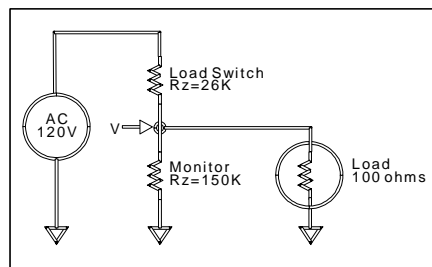

The leakage current can be easily estimated by knowing the value of the snubber components. A capacitor looks resistive to an ac voltage. The equivalent *impedance* is calculated as shown. Typical values for snubber capacitors range from 0.05uf to 0.1uf.

Most off-state signals will have a residual voltage due to this leakage current on the order of 0.5 Vac to 3 Vac depending on the value of the snubber and load. Since this value is less than the 15 V and 50 V thresholds, they are sensed as OFF.

The off-state voltage can be estimated by the leakage current (5ma) multiplied by the load resistance (100 ohms). When this off-state voltage increases to the 15 V to 25 V range on a Green or Yellow input, the monitor may incorrectly sense it as ON.

The maximum load impedance can be shown to be 2100 ohms for Green or Yellow, and 7000 ohms for Red. New technologies using solid state power supplies and LEDs must accommodate this *parameter*.

Capacitors can also be used as loads where power dissipation is an issue. Care should be taken since capacitor discharge times will skew the monitor sensing point and may cause Conflict or Dual Indication faults.

Example calculation for a 2000 ohm equivalent capacitor:

$$C = 1 / (2\pi fR) = 1.3 \text{ uf}$$

## Load Switch Leakage Current

- ◆ Loss of load does *not* produce a Red Fail!
  - »  $V_m = (150K / 176K) * 120V = 102 \text{ Vac}$
- ◆ The Monitor will detect a loss of load as an active signal.

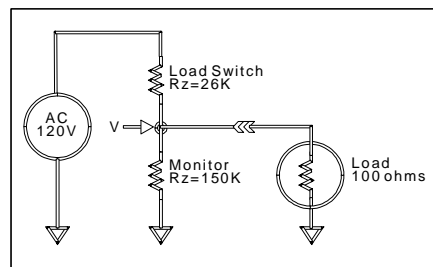

When the load is removed from the load switch output, the monitor becomes the load. Recalculating the off-state voltage shows a residual voltage of 102 Vac. This will be sensed as an *active* signal by the monitor whether it is a Green, Yellow, or Red.

Thus, a loss of load will not cause a Red Fail, but will be detected as a Conflict fault (for Green, Yellow) or a Dual Indication fault (for Green, Yellow, or Red).

A good trouble shooting practice is to measure the off-state voltage of each input and ensure that it is less than the monitor minimum threshold.

## 210E Hardware

---

- ◆ Red Enable Input
  - » Enables Red Fail, Dual Indication, Sequence
  - » Red Fail LED flashes when Red Monitoring function is OFF
- ◆ Special Function Inputs
  - » SF#1 and SF#2 inputs disable Red Fail monitoring function only
  - » Polarity option defines active / not active operation for SF#1

### Red Enable Input

This input must be active (>70 Vac) to enable Red Fail, Dual Indication, and Sequence monitoring. If Red Enable is not active, the Red Fail Led will flash to indicate enhanced monitoring functions are disabled.

The Red Fail Led will also flash if Red Fail monitoring is disabled due to the EE input (MC Coil) being active or the Special Function inputs active.

### Special Function Inputs

SF#1 and SF#2 will disable Red Fail monitoring when either input is active. This input is normally wired through a relay to an output from the CU which is activated during preemption or time-of-day flash. The Red Interface PCB provides this connection.

SF #1 and SF #2 use Red voltage thresholds (ON > 70 Vac, OFF < 50 Vac).

## 210E Hardware

---

- ◆ Programming Card
  - » Conflicting Channel Diodes
    - › No diode = Permissive pair!
  - » Yellow Disable Jumpers
- ◆ Red Interface Cable
  - » Provides Red 1:16, Red Enable, SF1:2, and Earth Ground (optional)

### Programming Card

A diode in place between a channel pair makes that pair CONFLICTING.

**NO diode in place between a channel pair makes that pair PERMISSIVE!**

### Yellow Disable Jumpers

A jumper forces the Yellow input state to OFF in the monitor. It can be used where no Yellow is monitored on a channel, as in a pedestrian channel, to disable Sequence monitoring.

### Red Interface Cable

This cable brings in the 16 Red inputs, Red Enable, Special Function #1 and #2, and Chassis Ground. Chassis Ground must be wired in cabinet also.

**IF IT IS NOT CONNECTED... RED FAIL, DUAL INDICATION, AND SEQUENCE MONITORING ARE DISABLED!**

## AC Line Power Failure

---

- ◆ CU AC Line Reset < monitor brownout
- ◆ 210E
  - » Low voltage dropout level is 92 Vac
  - » Restore voltage is 98 Vac
  - » Dropout & restore timing is 80 +/- 16 ms
- ◆ 2010
  - » Low voltage dropout level is 98 Vac
  - » Restore voltage is 103 Vac
  - » Dropout & restore timing is 400 +/- 50 ms

### **AC Line Brownout Flash mode**

#### **210 mode**

AC Line less than 92 Vrms, greater than 80 ms

Non-latching Fault (POWER LED flashes at 2 Hz)

AC Line greater than 98 Vrms, greater than 80 ms

No Fault (POWER LED illuminated)

#### **2010 mode (preferred)**

AC Line less than 98 Vrms, greater than 400 ms

Non-latching Fault (POWER LED flashes at 2 Hz)

AC Line greater than 103 Vrms, greater than 400 ms

No Fault (POWER LED illuminated)

POWER LED will change to a 4Hz flash rate during minimum flash interval.

CU dropout voltage must be less than monitor dropout voltage to prevent Red Fail at low AC Line. At least 5 Vac is recommended.

## Minimum Flash Function

---

- ◆ Minimum of 6 seconds of flash following a power-up, interrupt, or brownout restore
- ◆ 5 transitions of the Watchdog input will terminate the minimum flash interval after 6 seconds
- ◆ Maximum of 10 seconds of flash; WDT Error or Red Fail will result if CU fails to start

### **Minimum Flash Interval**

Following a power-up, or interrupt or brownout longer than 400 ms, the unit will time a minimum of 6 seconds of flash to allow the 2070 CU time to reboot and energize the signals and WDT output.

If the monitor detects 5 transitions of the Watchdog input after 6 seconds has elapsed, the minimum flash interval will be terminated and the Output relay energized (signals).

If the monitor does not detect 5 transitions of the Watchdog input before 10 seconds, a Watchdog or Red Fail fault will be detected.

## No Fault Diagnostic Display

---

- ◆ Used to view individual color field inputs during intersection operation.
- ◆ Reset button controls display:
  - » Green inputs: flash (G) AC POWER Led
  - » Yellow inputs: flash (Y) VDC FAILED Led
  - » Red inputs: flash (R) WDT ERROR Led
- ◆ Channel Status LEDs display individual color status.

This display mode can be used to display the individual colors one at a time during signal operation (No Fault).

The Reset button is pressed and held for each mode.

### **No Fault Display:**

| <u>Reset</u> | <u>Fault Status LEDs</u>   | <u>Channel Status LEDs</u> |
|--------------|----------------------------|----------------------------|
| #1           | (G) AC POWER LED flashes   | Green field status 1-16    |
| #2           | (Y) VDC FAILED LED flashes | Yellow field status 1-16   |
| #3           | (R) WDT ERROR LED flashes  | Red field status 1-16      |
| ...          | (repeats back to top)      |                            |

## Fault Diagnostic Display

---

- ◆ Used to view individual color field inputs during flash operation for past three faults.
- ◆ Remove Program Card, Reset button controls display:
  - » Multiple pulse on PCA Led indicates fault #1,2, or 3
  - » Fault & Fault Status are shown first
  - » Green inputs flash (G) AC POWER Led
  - » Yellow inputs flash (Y) VDC FAILED Led
  - » Red inputs flash (R) WDT ERROR Led

This display mode can be used to display the individual colors one at a time during flashing operation (Fault). It displays the status for three faults.

The Program Card must be removed to prevent the current fault from being reset. The Reset button is pressed for each mode.

### **Current/Previous Fault Display:**

| Reset | Event | PCA LED      | Fault Status LEDs              | Channel Status LEDs      |
|-------|-------|--------------|--------------------------------|--------------------------|
| —     | #1    | Single flash | Current Fault Status (newest)  | Current channel status   |
| #1    | #1    | Single flash | (G) AC POWER LED flashes       | Green field status 1-16  |
| #2    | #1    | Single flash | (Y) VDC FAILED LED flashes     | Yellow field status 1-16 |
| #3    | #1    | Single flash | (R) WDT ERROR LED flashes      | Red field status 1-16    |
| #4    | #2    | Double flash | Event #2 Fault Status          | Event #2 channel status  |
| #5    | #2    | Double flash | (G) AC POWER LED flashes       | Green field status 1-16  |
| #6    | #2    | Double flash | (Y) VDC FAILED LED flashes     | Yellow field status 1-16 |
| #7    | #2    | Double flash | (R) WDT ERROR LED flashes      | Red field status 1-16    |
| #8    | #3    | Triple flash | Event #3 Fault Status (oldest) | Event #3 channel status  |
| #9    | #3    | Triple flash | (G) AC POWER LED flashes       | Green field status 1-16  |
| #10   | #3    | Triple flash | (Y) VDC FAILED LED flashes     | Yellow field status 1-16 |
| #11   | #3    | Triple flash | (R) WDT ERROR LED flashes      | Red field status 1-16    |
|       |       | ...          | (repeats back to top)          |                          |

## 210E Option Switches (SW-3)

---

- ◆ RF 2010
  - » OFF = Red Fail fault time is 850ms.
  - » ON = Red Fail fault time is 1350ms.
- ◆ RP Disable
  - » ON = Recurrent Pulse detection is disabled.
- ◆ WD 1.0 SEC
  - » OFF = Watchdog fault timing set to 1.5 sec
  - » ON = Watchdog fault timing set to 1.0 sec
- ◆ GY ENABLE
  - » Provides G-Y Dual Indication monitoring for five section signal heads

### RF 2010

Selects the 210E series Red Fail fault time of 850ms or the 2010 fault time of 1350ms.

### RP DISABLE

In the ON position Recurrent Pulse Detection is *disabled*.

### WD 1.0 SEC

OFF = 1.5 Second WDT ERROR timing (Caltrans)

ON = 1.0 Second WDT ERROR timing

### GY ENABLE

This function may be used to accommodate 5 section signal heads with the missing Red arrow input tied to AC Line.

If the GY ENABLE switch is in the ON position, then any channel that has its SSM Switch in the OFF position will still detect a (G and Y) Dual Indication fault on that channel.

If the GY ENABLE switch is in the OFF position, then any channel that has its SSM Switch in the OFF position will not detect any Dual Indication fault on that channel.

**The *name* of the option switch is what happens when the switch is in the ON position.**

## 210E Option Switches (SW-3)

- ◆ Special Function input POLARITY
  - » OFF: SF#1 input *active* disables Red Fail monitoring
  - » ON: SF#1 input *not active* disables Red Fail monitoring
- ◆ Yellow Time Switches
  - » Minimum Yellow = 2.7 + (s3,s2,s1 \* 0.2) seconds

### SPECIAL FUNCTION POLARITY

| <u>Polarity Switch</u> | <u>SF #1</u> | <u>SF #2</u> | <u>Red Failure Monitoring</u> |
|------------------------|--------------|--------------|-------------------------------|
| off                    | off          | off          | enabled                       |
| off                    | off          | on           | disabled - Preempt            |
| off                    | on           | off          | disabled - Preempt            |
| off                    | on           | on           | disabled - Preempt            |
| on                     | off          | off          | disabled - Preempt            |
| on                     | off          | on           | disabled - Preempt            |
| on                     | on           | off          | enabled                       |
| on                     | on           | on           | disabled - Preempt            |

SF #1 and SF #2 use Red voltage thresholds (ON > 70 Vac, OFF < 50 Vac).

### YELLOW TIME 1,2,3

These switches set the minimum Yellow clearance interval fault time. They are binary coded and add to the base 2.7 second minimum. This setting must accommodate the shortest Yellow clearance time of all phases.

Add 0.2 sec for YEL TIME 1, 0.4 sec for YEL TIME 2, and 0.8 sec for YEL TIME 3.

$$t = 2.7 + (0 \text{ to } 1.4 \text{ seconds}) = 2.7 \text{ to } 4.1 \text{ seconds}$$

## 210E Options

---

- ◆ Watchdog Enable (SW-2)
  - » Enables WDT ERROR monitor
  - » WDT ERROR Led flashes if disabled
- ◆ Watchdog Latch Enable
  - » SEL1 jumper enables latch mode.
  - » Caltrans mode will reset WDT ERROR following brownout restore
  - » Latch option requires reset to clear fault

### WATCHDOG ENABLE SWITCH

This switch will enable the Watchdog monitor function when placed in the ON position. This switch is intended to aid in trouble shooting a malfunctioning cabinet. The intersection should not be operated with this function disabled.

### WATCHDOG LATCH ENABLE

#### Jumper out:

AC Line brownout restore will clear a WDT ERROR and allow the intersection to run. The WDT ERROR LED will remain illuminated until Reset (Caltrans).

#### Jumper in:

WDT ERROR is latched until Reset button is depressed or External Reset input is activated.

## 210E Options

---

- ◆ Onboard uP Watchdog Latch Enable
  - » “Latching MPU Fault” jumper enables latch function
  - » Monitors onboard uP for proper operation
  - » Latches fault until power-up cycle, if enabled
  - » DIAGNOSTIC LED illuminates if tripped

### MPU FAIL LATCH (E5)

An internal mpu watchdog circuit will trip for a malfunctioning on-board microprocessor and transfer the Output relay. This jumper determines if latching operation occurs.

If latching is enabled (jumper IN), only a power-down cycle will clear the fault.

If latching is not enabled (jumper OUT), the on-chip uP watchdog circuit may restart the microprocessor.

## 210E Options

---

- ◆ Minimum Flash Enable
  - » SEL2 jumper enables minimum flash interval on power-up, brownout restore, or interrupt restore. Required for 2070 compatibility
- ◆ Configuration Change Fault Enable
  - » SEL3 jumper enables fault mode
  - » Configuration Change is always logged
- ◆ Red Cable Fault Enable
  - » SEL4 jumper enables fault mode if Red Cable is removed during operation.

### MINIMUM FLASH ENABLE

Jumper IN enables minimum flash interval on power-up, AC Line brownout restore, and AC Line interrupt restore. This function is required for compatibility with the 2070 Controller Unit. It is a preferred mode for 170 CU operation as well. This mode reflects typical NEMA start-up operation.

### CONFIGURATION CHANGE ENABLE

With the jumper IN, a configuration change will be logged and trigger a fault. The PCA LED will flash at a 4Hz rate to indicate this fault. A five second manual reset is required to enter the new configuration and reset the unit.

With the jumper OUT, the change will be logged but no fault is triggered.

### RED CABLE FAULT ENABLE

With the jumper IN, the monitor will go to Red Fail fault if the Red Interface cable is removed (Channel Status = Off).

With the jumper OUT, the unit will function as basic 210 monitor with Red Fail, Dual Indication, and Sequence disabled when the Red Interface cable is not connected.

## 210E SSM Switches (SW-4,5)

- ◆ SSM switches enable both Sequence and Dual Indication monitoring when in the ON position
- ◆ SSM switches should be in the ON position for vehicle channels and other channels which have a true Red, Yellow, and Green load

SSM Switches in the ON position enable the Dual Indication and Sequence monitoring functions on an individual channel basis.

An SSM Enable switch should be OFF for channels that have the Red input tied to AC Line such as the left turn channel of a 5 section head, pedestrian channel, or any unused channels. An SSM Enable switch should also be OFF for any channels that do not monitor all three outputs of the corresponding Load Switch such as a pedestrian channel with no Yellow load.

If 5 section heads are used for protected / permissive phases, the GY ENABLE option should be considered.

EDI 210E

---

Setting the Standard  
for  
Quality and Reliability

Eberle Design Inc.

Thank you for using Eberle Design products.

Our goal is to provide you with the highest reliability, performance, and customer satisfaction possible.

Your inputs and comments are highly appreciated.