

Model 242E

Enhanced DC Isolator Unit Operations Manual

THIS MANUAL CONTAINS TECHNICAL INFORMATION FOR THE MODEL 242E SERIES ENHANCED DC ISOLATOR. INCLUDED ARE GENERAL DESCRIPTION, OPERATIONAL DESCRIPTION, INSTALLATION, AND SPECIFICATIONS.

THE MODEL 242E SERIES ENHANCED DC ISOLATOR IS DESIGNED AND MANUFACTURED IN THE USA BY EBERLE DESIGN INC., PHOENIX, ARIZONA.

INFORMATION CONTAINED HEREIN IS PROPRIETARY TECHNICAL INFORMATION OF EBERLE DESIGN INC. PUBLICATION, REPRODUCTION OR USE IN WHOLE OR PART IS NOT PERMITTED EXCEPT UNDER TERMS AGREED UPON IN WRITING. U.S. PATENT NO. 7,855,893

© COPYRIGHT 2011 EDI.

SERIAL NUMBER: 1101XXXXX and up
PCB Issue B, 010-0242-001

REVISION: JANUARY 2011
pn 888-0242-003

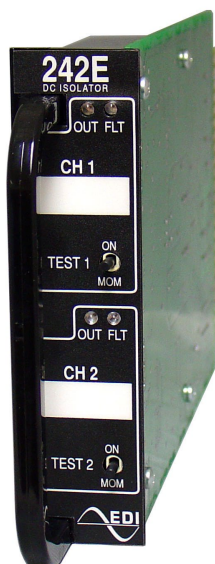

EBERLE DESIGN INC.

3510 East Atlanta Avenue
Phoenix, AZ 85040 USA
www.EDITraffic.com

Tel (480) 968-6407
Fax (602) 437-1996



Table of Contents

1.1 General Description	1
1.2 Enhanced Features	1
1.3 General Characteristics	1
1.4 Installation and Adjustments	1
1.4.1 Output Polarity	1
1.4.2 Output Minimum Pulse Width.....	2
1.4.3 Input Pulse Filtering	2
1.5 Output (OUT) and Fault (FLT) Indicators.....	2
1.6 Theory of Operation.....	2
1.6.1 System Description.....	2
1.6.2 Input Circuit	3
1.6.3 MCU Circuit	3
1.6.4 Output Circuit.....	3
1.6.5 Display and Switch Circuit.....	3
1.6.6 Power Supply Circuit.....	3
1.7 Maintenance	3
1.7.1 Trouble Analysis	3
1.7.2 Trouble Shooting Sequence.....	4
1.8 Specifications	4
1.8.1 Construction	4
1.8.2 Mechanical	4
1.8.3 Environmental.....	4
1.8.4 Electrical.....	4
1.8.5 Timing	5
1.8.6 Connections.....	5
1.9 Parts List and Schematic	6

1.1 GENERAL DESCRIPTION

The Eberle Design Model 242E is a dual channel DC Isolator unit designed to meet Caltrans specifications TSCES 1989, and TEES August 2002 Chapter 1. The isolator unit occupies one position of a 170 standard input file. The isolator unit card incorporates a double-sided 44 pin edge connector for the connection of power, input, and output signals. Each channel has individual front panel controls for testing the operational mode, and high intensity front panel LEDs which are used to indicate the output state and a fault condition on the output. Outputs are optically-isolated solid-state transistors.

1.2 ENHANCED FEATURES

The Model 242E builds on the standard DC Isolator capabilities by adding:

- Additional Fault Output indicators to alert a technician to problems with the Model 242E outputs or associated Controller Unit inputs. This simplifies diagnosing problems due to output or input circuit problems or wiring errors.
- Three separate Input Pulse filter settings per channel provide a mechanism to screen out transient input pulses that may be the result of noise conditions or signal bounce. In some cases additional filtering can be used to ensure critical signals such as Flash Sense are not improperly processed by the Controller Unit due to transient noise injected into the cabinet wiring system, for example.
- The polarity of the output signal can also be inverted individually for each channel.

1.3 GENERAL CHARACTERISTICS

Each channel of the Model 242E provides input hysteresis and digital filtering to qualify the input signal. An input signal must meet the minimum pulse requirements specified in section 1.8.5 in order to produce a valid True output.

Both the input and output circuits have been designed for maximum protection from electrical transients. The inputs have been designed to withstand the discharge of a 10 uF capacitor charged to +/- 1000 Vdc directly across the input pins, and a discharge of a 10 uF capacitor charged to +/- 2000 Vdc applied through a source impedance of 5 ohms across the input pins or to Equipment Ground. The outputs are protected by a transient clamp diode.

The Model 242E handle assembly is made of GE Lexan™ Type 121, which is a super durable polycarbonate resin. The design of this assembly strengthens and protects the whole PCB assembly much better than conventional metal face plates.

1.4 INSTALLATION AND ADJUSTMENTS

Installation of the unit consists of plugging into the appropriate slot of the Input File and connecting the assigned inputs to the proper cabinet terminals. The edge connector is keyed to prevent incorrect installation.

Following power-up, a front panel LED test will illuminate all indicators for two seconds.

1.4.1 OUTPUT POLARITY

If desired, the output polarity for Channel 1 and Channel 2 can each be inverted by setting the DIP switches SW1.1 and SW1.4 marked "Polarity" to the ON position. The polarity may also be inverted by installing optional jumpers SEL1 and SEL2 respectively.

Polarity Switch	Input	Output
OFF	True	True
	False	False
ON	True	False
	False	True

1.4.2 OUTPUT MINIMUM PULSE WIDTH

If desired, the output pulse width for both channels can be set to 100 milliseconds minimum by installing jumper SEL3.

1.4.3 INPUT PULSE FILTERING

Each channel can be individually configured to modify the default input pulse width specifications described in section 1.8.5.

Polarity Switch	Filter B Switch	Filter A Switch	Input Open → Closed	Input Closed → Open	Minimum Input Pulse Width Accept
OFF	OFF	OFF	10 ms	10 ms	10 ms
OFF	OFF	ON	100 ms	10ms	100 ms
OFF	ON	OFF	100 ms	100 ms	100 ms
OFF	ON	ON	200 ms	10 ms	200 ms
ON	OFF	OFF	10 ms	10 ms	10 ms
ON	OFF	ON	10 ms	100ms	10 ms
ON	ON	OFF	100 ms	100 ms	100 ms
ON	ON	ON	10 ms	200 ms	10 ms

1.5 OUTPUT (OUT) AND FAULT (FLT) INDICATORS

Each channel provides an OUT and FLT indicator. The OUT indicator illuminates when the input meets the Pulse Width Accept specifications of 1.8.5 (or as modified by the Filtering settings of 1.4.2). This state is intended to produce the True (low) state to the controller unit.

If a cabinet fault or isolator output failure causes the true electrical state of the output to differ from the intended state, the FLT indicator will illuminate. This may be caused by a failure of the Model 242E output circuit, a wiring malfunction in the cabinet, or an input circuit malfunction in the controller unit.

1.6 THEORY OF OPERATION

Reference designators shown are for Channel 1. Designators for channel 2 are shown in brackets [].

1.6.1 SYSTEM DESCRIPTION

The sensor circuitry can be broken down into seven major blocks. Each “Input Circuit” block contains the electrical transient devices and the input biasing circuit. Although the Model 242E has two DC inputs, a single digital processing section is used to process both inputs.

The microcontroller unit “MCU” Block provides the input voltage threshold and input pulse width filtering function on both channel 1 and channel 2 DC input circuits.

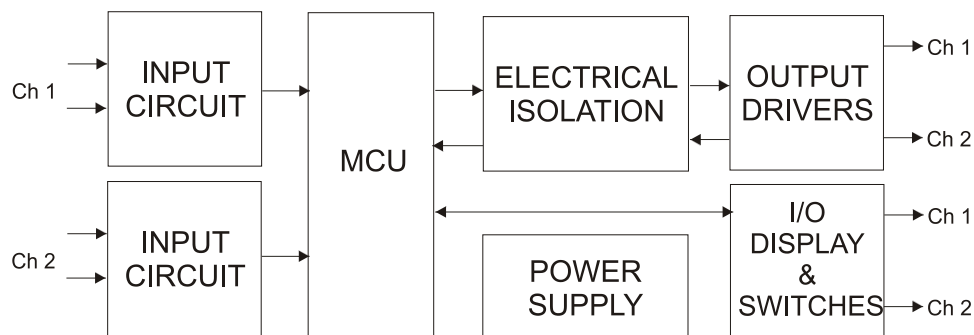

The MCU then controls the OUTPUT and DISPLAY blocks appropriately. If jumper SEL3 is installed a valid input pulse will generate an output pulse of 100 milliseconds minimum.

The microcontroller also reads the state of the TEST switches on the front panel. If the TEST switch is in the ON (locked) or MOM (momentary) position it will force the output to the asserted (True) state regardless of the input circuit state. The TEST switches are processed through the MCU for pulse width input and output requirements.

Valid output calls are made via optically isolated solid state transistors. Output calls are indicated on the front panel by means of high intensity LEDs labeled "OUT".

The Model 242E operating voltage is generated by a high efficiency off-line switching power supply. The VDD supply for the microcontroller and display elements results from a post regulated 5 Vdc.

1.6.2 INPUT CIRCUIT

Resistors R5, R7, R11, and R12 [R6, R8, R13, and R17] provide the input bias and voltage scaling circuit. The resulting voltage at U8.8 [U8.9] is then processed by the microcontroller U8. Metal Oxide Varistor RV4 [RV5] provides input electrical transient protection.

1.6.3 MCU CIRCUIT

The microcontroller U8 processes the input voltages to perform the voltage threshold and pulse width filtering functions. All signal processing is performed in the digital domain and controlled by firmware embedded in the microcontroller. This unit does not rely on analog delay, pulse, or comparator circuits for processing the input signals.

1.6.4 OUTPUT CIRCUIT

The output driver Q2 [Q1] is isolated from both the AC Mains and the internal GND reference of the Model 242E by opto-couplers U6 [U2]. CR1 [CR2] provides electrical transient protection for the output driver Q2 [Q1].

The actual electrical state of the output circuit is monitored by the MCU via opto-coupler U7 [U3]. This output state is used to generate the FLT indicator status on DS1.4 [DS2.4].

1.6.5 DISPLAY AND SWITCH CIRCUIT

The OUT LED indicator DS1.3 [DS2.3] for the channel output is driven directly from the microcontroller U8. The input TEST switch SW4 [SW5] is read by the microcontroller U8 using strobe U8.19 [U8.18].

1.6.6 POWER SUPPLY CIRCUIT

The main power supply is a fully isolated switching design. MOV RV7 provides electrical transient protection. The AC Mains voltage is rectified and charges C3 to a nominal 170 Vdc. Controller U1 drives transformer T1 at approximately 144 KHz to produce an isolated DC voltage at C15, C16, and C17. Inductor L1 and C14 filter the high frequency switching noise. The resulting voltage at VCC is regulated to 19.0 +/- 1 Vdc. The opto-coupler U4 and reference U5 provide the closed loop feedback to the power supply controller U1 for regulation. Regulator VR1 regulates VCC down to 5.0 Vdc for the microcontroller U8.

1.7 MAINTENANCE

The Model 242E requires no adjustments or preventive maintenance.

1.7.1 TROUBLE ANALYSIS

The following list should be used to trouble-shoot the Model 242E installation. If the Model 242E unit itself is suspect, see Section 1.7.2 for a complete internal testing sequence.

- a. Neither channel responds to DC inputs
 - a. Power supply fault

The Model 242E requires a 115 Vac nominal supply. The unit will operate at voltages as low as 80 Vac, however, an AC Mains voltage below this may result in the unit entering a reset state. In this case, the unit will appear to be non-functional.

- b. Channel does not detect all inputs
 - a. Input voltage or pulse width does not meet the requirements of section 1.8.4 or 1.8.5.
Verify that the DC input voltage level is less than the DC Inputs True specification. Verify that the DC input pulse width is greater than the Input Pulse Width Accept specification.

1.7.2 TROUBLE SHOOTING SEQUENCE

Apply 115 Vac nominal mains power to AC+ pin J1-N referenced to AC- pin J1-M. Connect a jumper circuit to the DC inputs J1-D [J1-J] and J1-E [J1-K] to simulate the closure of the input contacts. The following signal measurements are referenced to test point “GND”.

NOTE: internal test point “GND” is isolated from AC-. Care should be exercised in probing internal test points.

- a. Input Bias Power Supply
Voltage at test point V_UNF should be 19 ± 1 Vdc.
Possible component faults are: controller U1, diodes CR10 and CR14, transformer T1, inductor L1, or opto-coupler U4.
- b. Regulated Power Supply
Voltage at test point VDD should be 5 ± 0.2 Vdc.
Possible component faults are: voltage regulator VR1.
- c. Microcontroller
Waveform at pin 5 of P1 (or U8.18) should be a 2.5 us high to low pulse every 1 millisecond.
Possible components at fault are: microcontroller U8.
- d. Output Circuit
Output signals are processed by the microcontroller U8 and appear at U8.6 [U8.5] and on the display LEDs but are not appearing at the output pins.
Possible components at fault are: opto-coupler U6 [U2], output transistor Q2 [Q1].

1.8 SPECIFICATIONS

1.8.1 CONSTRUCTION

1.8.2 MECHANICAL

Height	4.50 inches
Width	1.2 inches
Depth (excluding handle).....	6.875 inches

1.8.3 ENVIRONMENTAL

Storage Temperature Range	-45 to +85 °C
Operating Temperature Range	-34 to +74 °C
Humidity Range (non-condensing).....	0 to 95% Relative

1.8.4 ELECTRICAL

AC Supply Voltage Minimum	80 Vac
AC Supply Voltage Maximum	135 Vac
AC Supply Power Maximum	2.5 Watts
DC Inputs	
True (low)	less than 8 Vdc
False (high).....	greater than 12 Vdc
Optically Isolated Solid State Outputs	
True (low, 50 mA)	less than 1.5 Vdc
False (high).....	greater than 16 Vdc

Maximum Leakage Current (high) less than 1 uA
 Maximum Current 50 mA
 Collector Voltage Maximum..... 50 Vdc

1.8.5 TIMING

Input Pulse Width Reject (Filter A & B Off).....less than 5 ms
 Input Pulse Width Accept (Filter A & B Off) greater than 25 ms
 Input Pulse Width Accept (Filter A & B Off) typical 10 ms

1.8.6 CONNECTIONS

Edge Connector mates with connector type Cinch 50-44A-30

PIN	FUNCTION
D	Input CH 1
E	Input CH 1 Common
F	CH 1 Output Collector
H	CH 1 Output Emitter
J	Input CH 2
K	Input CH 2 Common
L	Equipment Ground
M	AC -
N	AC +
W	CH 2 Output Collector
X	CH 2 Output Emitter

1.9 PARTS LIST AND SCHEMATIC

Item	EDI Part Number	Qty	Description	Reference	Manufacturer
1		1	(NO COMPONENT)	J1	
2		6	(NO COMPONENT)	GND HV+ HV- VCC VDD	
3		2	(NO COMPONENT)	SEL4-5	
4		1	(NO COMPONENT)	E3	
5		2		M1-2	
6		1	PIC Programming Port	P1	
7	215-5610-S	4	Resistor, 560 OHMS, 1/2W, 5%, 2010 surf. mnt.	R5-8	
8	220-5600-S	2	RESISTOR,1W,56 Ohm,5%,2512 SMD	R3-4	PANASONIC
9	251-1052-S	3	RESISTOR, 1/8W, 10.5K, 1%, 1206 surface mount	R11 R13 R30	
10	251-1211-S	1	RESISTOR, 1/8W, 1.21K, 1%, 1206 surface mount	R26	
11	251-1961-S	3	RESISTOR, 1/8W, 1.96K, 1%, 1206 surface mount	R12 R17 R31	
12	251-8061-S	1	RESISTOR, 1/8W, 8.06K, 1%, 1206 surface mount	R25	
13	255-0000-S	2		E4 E6	
14	255-0000-S	3	RESISTOR, 1/8W, 0 OHMS, 5%, 1206 surface mount	E2 E7 E9	
15	255-1020-S	3	RESISTOR, 1/8W, 1K, 5%, 1206 surface mount	R21 R24 R32	
16	255-1030-S	2	RESISTOR, 1/8W, 10K, 5%, 1206 surface mount	R14-15	
17	255-1040-S	2	RESISTOR, 1/8W, 100K, 5%, 1206 surface mount	R22 R33	
18	255-2700-S	2	RESISTOR, 1/8W, 27 Ohm, 5%, 1206 surface mount	R10 R28	
19	255-4310-S	1	RESISTOR, 1/8W, 430 Ohm, 5%, 1206 surface mount	R27	
20	255-4720-S	4	RESISTOR, 1/8W, 4.7K, 5%, 1206 surface mount	R1-2 R9 R29	
21	255-4730-S	2	RESISTOR, 1/8W, 47K, 5%, 1206 surface mount	R19-20	
22	255-5110-S	2	RESISTOR, 1/8W, 510 Ohm, 5%, 1206 surface mount	R16 R18	
23	255-6210-S	4	RESISTOR, 1/8W, 620 Ohm, 5%, 1206 surface mount	R34-37	
24	300-1070-035S	1	CAPACITOR, ELECTROLYTIC, 100uF, 35V, 20%, SMT,6.3	C7	
			x 8		
25	300-3360-250R	1	CAPACITOR, ELECT, 33uF, 250WV, 20 %, RDL	C3	ILLINOIS 336CKR250M
26	300-3370-035S	1	CAPACITOR, ELECTROLYTIC, 330uF, 35V, LOW ESR, 20%, SMT	C14	ILLINOIS 227AXZ016M

Model 242E Operations Manual

27	300-3370-035S	2	CAPACITOR, ELECTROLYTIC, 330uF, 35V, LOW ESR, 20%, SMT	C16-17	NICHICON UPL1V221MPH
28	310-1060-006S	1	CAPACITOR, TANTALUM, 10UF, 6.3V, 20%, 1206 CHIP	C18	PANASONIC ECSTOJY106R
29	320-1020-050S	2	CAPACITOR, CER.MULT, 0.001uF, 50V, 10%, 1206 CHIP	C10 C13	
30	320-1030-100S	2	CAPACITOR, CER.MULT, 0.01uF, 100V, 10%, 1206 CHIP	C8-9	
31	320-1040-050S	5	CAPACITOR, CER.MULT, 0.1uF, 50V, 10%, 1206 CHIP	C1-2 C15 C19-20	
32	325-1010-500R	1	CAPACITOR, CER.DIS, 100pF, 500V, 10%, RDL	C12	PANASONIC
33	325-4700-500R	1	CAPACITOR, CER.DIS, 47pF, 500V, 10%, RDL	C11	PANASONIC
34	335-1040-630R	2	CAPACITOR, 0.1UF, 630V, 10%, METALIZED FILM, 15mm	C5-6	
35	410-0053-S	2	DIODE, TRANS. SUPR., SMA5.0A, 5V,SMA	CR9 CR11	MOTOROLA
36	410-0140-S	1	DIODE, SCHOTTKY, MBRS140T3, 40V,1A, SMB	CR14	ON SEMI
37	410-0160-S	1	DIODE, ULTRAF, MURA160T3, 600V,1A, SMA	CR10	ON SEMI
38	410-1526-S	1	TRANSORB, SMCJ26A, 26V, 1500W	CR13	DIODES, INC.
39	410-4005-S	8	DIODE, S1K, 800 PIV, 1A	CR3-8 CR21-22	
40	410-4148-S	8	DIODE, 1N4148WS, SMT SOD323	CR15-20 CR23-24	DIODES INC.
41	410-4755-S	2	DIODE, ZENER, CMZ5941B, 1.0W, 5%, 43V,SMA	CR1-2	
42	420-2811-S	5	OPTOCOUPLER, PS2801-1, 4 PIN SOP	U2-4 U6-7	NEC PS2801-1
43	425-0318	2	DISPLAY, LED MODULE, DUAL, RA, HIGH BRIGHTNESS	DS1-2	
44	430-0006-S	2	TRANSISTOR, MMBTA06LT1, NPN, 80V, 500 mA,SOT-23	Q1-2	
45	440-0030	2	REGULATOR, METAL OXIDE VARISTOR	RV4-5	
46	440-0150	1	REGULATOR, METAL OXIDE VARISTOR, S14K150	RV7	
47	440-0431-S	1	REGULATOR, TL431AID, VOLTAGE REF., 1%, SO8	U5	MOTOROLA
48	440-1051-S	1	REGULATOR, SWITCHING, OFFLINE	U1	ON SEMI NCP1051ST136T3
49	440-7805-S	1	MC7805BD2T, 5V REG., 1A, D2PAK	VR1	MOTOROLA
50	485-0687-S	1	PIC16F687-I/SS, PROC, 20PIN SSOP	U8	MICROCHIP PIC16F687-I/SS
51	520-0102-P	1	Connector, Header, 2 Pin, Samtec	SEL3	
52	610-0078-S	2	SWITCH, SPDT, ON-OFF-MOM, TOGGLE, SMT	SW4-5	APEM TL38WS84065
53	630-0060	1	SWITCH, DIP-SWITCH, 6 POS	SW1	C&K
54	780-0060	1		CVR1	
55	800-0140	1	TRANSFORMER, PCMT, OFFLINE,2.5W	T1	TRANSTEK MAGNETICS
					TMP60543CT
56	850-0047-S	1	INDUCTOR, 4.7uH, SMT 1210	L1	

