

# State of California Model 242

---

---

## DC Isolator Unit Operations Manual

SERIAL NUMBER: 0601XXXXX and up

PCB Issue B, 010-0242-001

REVISION: MAY 2006

pn 888-0242-001

### Table of Contents

1.1 Glossary .....	1
1.2 General Description .....	1
1.3 General Characteristics .....	1
1.4 Installation and Adjustments .....	1
1.5 Theory of Operation .....	2
1.5.1 System Description .....	2
1.5.2 Input Circuit .....	2
1.5.3 MCU Circuit .....	2
1.5.4 Output Circuit .....	3
1.5.5 Display and Switch Circuit .....	3
1.5.6 Power Supply Circuit .....	3
1.6 Maintenance .....	3
1.6.1 Trouble Analysis .....	3
1.6.2 Trouble Shooting Sequence .....	3
1.7 Specifications .....	4
1.7.1 Construction .....	4
1.7.2 Mechanical .....	4
1.7.3 Environmental .....	4
1.7.4 Electrical .....	4
1.7.5 Timing .....	4
1.7.6 Connections .....	4
1.8 Parts List and Schematic .....	6

EBERLE DESIGN INC.

3510 East Atlanta Avenue      Tel (480) 968-6407  
Phoenix, AZ 85040 USA      Fax (602) 437-1996  
www.EDIttraffic.com



THE MODEL 242 DC ISOLATOR UNIT IS DESIGNED AND MANUFACTURED IN THE USA  
U.S. PATENT NO. 7,855,893 © COPYRIGHT 2006 EDI

## 1.1 GLOSSARY

A - Ampere

°C - Celsius

Component - Any electrical or electronic device

DC - Direct Current

Firmware – Program code embedded into a microcontroller unit

Hz - Hertz

IC - Integrated Circuit

Jumper - A means of connecting/disconnecting two or more conductive by soldering/desoldering a conductive wire or by PCB post jumper

LED - Light Emitting Diode

LOGIC - Negative Logic Convention (Ground True) State

mA - milliAmpere

ms - millisecond

MCU - Micro Controller Unit or microcontroller unit

MOV - Metal Oxide Varistor

Opto-coupler – An integrated circuit that provides electrical isolation

PCB - Printed Circuit Board

RMS - Root-Mean-Square

s – second

Schmitt Circuit – a circuit that provides hysteresis in the threshold

SW – Switch

uF - microfarad

VAC - Voltage Alternating Current

VDC - Voltage Direct Current

## 1.2 GENERAL DESCRIPTION

The Eberle Design Model 242 is a dual channel DC Isolator unit designed to meet Caltrans specifications TSCES 1989, TSCES addendum of July 1991, and TEES August 2002 Chapter 1. The isolator unit occupies one position of a 170 standard input file. The isolator unit card incorporates a double-sided 44 pin edge connector for the connection of power, input, and output signals. Each channel has individual front panel controls for testing the operational mode, and high intensity front panel LEDs which are used to indicate the output state. Outputs are optically-isolated solid-state transistors.

## 1.3 GENERAL CHARACTERISTICS

Each channel of the Model 242 provides input hysteresis and digital filtering to qualify the input signal. An input signal must meet the minimum pulse requirements specified in section 1.7.5 in order to produce a valid output. The output pulse width for both channels can be set to 100 milliseconds minimum by installing jumper SEL3.

Both the input and output circuits have been designed for maximum protection from electrical transients. The inputs have been designed to withstand the discharge of a 10 uF capacitor charged to +/- 1000 Vdc directly across the input pins, and a discharge of a 10 uF capacitor charged to +/- 2000 Vdc applied through a source impedance of 5 ohms across the input pins or to Equipment Ground. The outputs are protected by a transient clamp diode.

The Model 242 handle assembly is made of GE Lexan™ Type 121, which is a super durable polycarbonate resin. The design of this assembly strengthens and protects the whole PCB assembly much better than conventional metal face plates.

## 1.4 INSTALLATION AND ADJUSTMENTS

Installation of the unit consists of plugging into the appropriate slot of the Input File and connecting the assigned inputs to the proper cabinet terminals. The edge connector is keyed to prevent incorrect installation. Following power-up, a front panel LED test will illuminate both OUT indicators for two seconds.

If desired, the output pulse width for both channels can be set to 100 milliseconds minimum by installing jumper SEL3.

## 1.5 THEORY OF OPERATION

Reference designators shown are for Channel 1. Reference designators for channel 2 are shown in parenthesis.

### 1.5.1 SYSTEM DESCRIPTION

The sensor circuitry can be broken down into seven major blocks. Each “Input Circuit” block contains the electrical transient devices and the input biasing circuit. Although the Model 242 has two DC inputs, a single digital processing section is used to process both inputs.

The microcontroller unit “MCU” Block provides the input voltage threshold and input pulse width filtering function on both channel 1 and channel 2 DC input circuits.

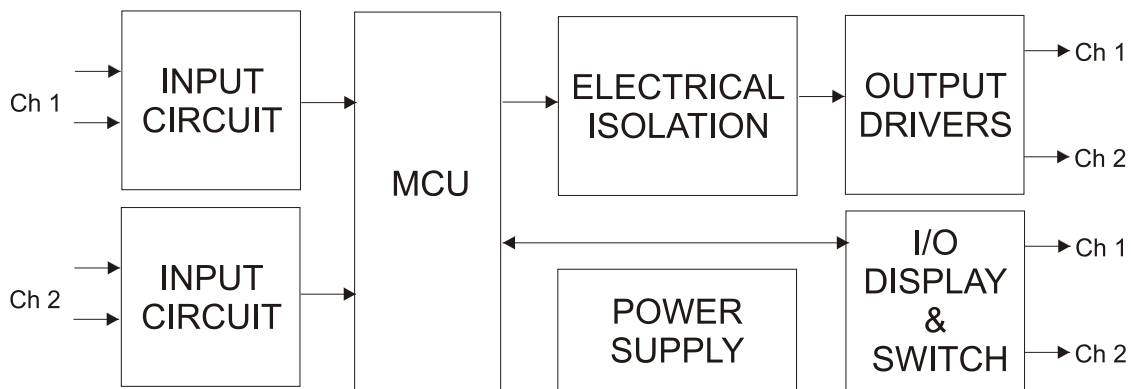

The MCU then controls the OUTPUT and DISPLAY blocks appropriately. If jumper SEL3 is installed a valid input pulse will generate an output pulse of 100 milliseconds minimum.

The microcontroller also reads the state of the TEST switches on the front panel. If the TEST switch is in the ON (locked) or MOM (momentary) position it will force the output to the asserted (True) state regardless of the input circuit state. The TEST switches are processed through the MCU for pulse width input and output requirements.

Valid output calls are made via optically isolated solid state transistors. Output calls are indicated on the front panel by means of high intensity LEDs labeled “OUT”.

The Model 242 operating voltage is generated by a high efficiency off-line switching power supply. The VDD supply for the microcontroller and display elements results from a post regulated 5 Vdc.

### 1.5.2 INPUT CIRCUIT

Resistors R5, R7, R11, and R12 (R6, R8, R13, and R17) provide the input bias and voltage scaling circuit. The resulting voltage at U8.8 (U8.9) is then processed by the microcontroller U8. Metal Oxide Varistor RV4 (RV5) provides input electrical transient protection.

### 1.5.3 MCU CIRCUIT

The microcontroller U8 processes the input voltages to perform the voltage threshold and pulse width filtering functions. All signal processing is performed in the digital domain and controlled by firmware embedded in the microcontroller. This unit does not rely on analog delay, pulse, or comparator circuits for processing the input signals.

### 1.5.4 OUTPUT CIRCUIT

The output driver Q2 (Q1) is isolated from both the AC Mains and the internal GND reference of the Model 242 by opto-couplers U6 (U2). CR1 (CR2) provides electrical transient protection for the output driver Q2 (Q1).

### 1.5.5 DISPLAY AND SWITCH CIRCUIT

The LED indicator DS1 (DS2) for the channel output is driven directly from the microcontroller U8. The input TEST switch SW4 (SW5) is read by the microcontroller U8 using strobe U8.19 (U8.18).

### 1.5.6 POWER SUPPLY CIRCUIT

The main power supply is a fully isolated switching design. MOV RV7 provides electrical transient protection. The AC Mains voltage is rectified and charges C3 to a nominal 170 Vdc. Controller U1 drives transformer T1 at approximately 144 KHz to produce an isolated DC voltage at C15, C16, and C17. Inductor L1 and C14 filter the high frequency switching noise. The resulting voltage at VCC is regulated to 19.0 +/- 1 Vdc. The opto-coupler U4 and reference U5 provide the closed loop feedback to the power supply controller U1 for regulation. Regulator VR1 regulates VCC down to 5.0 Vdc for the microcontroller U8.

## 1.6 MAINTENANCE

The Model 242 requires no adjustments or preventive maintenance.

### 1.6.1 TROUBLE ANALYSIS

The following list should be used to trouble-shoot the Model 242 installation. If the Model 242 unit itself is suspect, see Section 1.6.2 for a complete internal testing sequence.

- a. Neither channel responds to DC inputs
  - a. Power supply fault  
The Model 242 requires a 115 Vac nominal supply. The unit will operate at voltages as low as 80 Vac, however, an AC Mains voltage below this may result in the unit entering a reset state. In this case, the unit will appear to be non-functional.
  - b. Channel does not detect all inputs
    - a. Input voltage or pulse width does not meet the requirements of section 1.7.4 or 1.7.5.  
Verify that the DC input voltage level is less than the DC Inputs True specification.  
Verify that the DC input pulse width is greater than the Input Pulse Width Accept specification.

### 1.6.2 TROUBLE SHOOTING SEQUENCE

Apply 115 Vac nominal mains power to AC+ pin J1-N referenced to AC- pin J1-M. Connect a jumper circuit to the DC inputs J1-D (J1-J) and J1-E (J1-K) to simulate the closure of the input contacts. The following signal measurements are referenced to test point "GND".

NOTE: internal test point "GND" is isolated from AC-. Care should be exercised in probing internal test points.

- a. Input Bias Power Supply  
Voltage at test point V\_UNF should be  $19 \pm 1$  Vdc.  
Possible component faults are: controller U1, diodes CR10 and CR14, transformer T1, inductor L1, or opto-coupler U4.
- b. Regulated Power Supply  
Voltage at test point VDD should be  $5 \pm 0.2$  Vdc.  
Possible component faults are: voltage regulator VR1.
- c. Microcontroller  
Waveform at pin 5 of P1 (or U8.18) should be a 2.5 us high to low pulse every 1 millisecond.

Possible components at fault are: microcontroller U8.

d. Output Circuit

Output signals are processed by the microcontroller U8 and appear at U8.6 (U8.5) and on the display LEDs but are not appearing at the output pins.

Possible components at fault are: opto-coupler U6 (U2), output transistor Q2 (Q1).

**1.7 SPECIFICATIONS**

**1.7.1 CONSTRUCTION**

Printed circuit boards are double sided 2 oz. (56.70 gm.) copper with plated through holes. Circuit boards are coated for environmental protection.

**1.7.2 MECHANICAL**

Height ..... 4.50 inches  
 Width ..... 1.2 inches  
 Depth (excluding handle) ..... 6.875 inches

**1.7.3 ENVIRONMENTAL**

Storage Temperature Range..... -45 to +85 °C  
 Operating Temperature Range ..... -34 to +74 °C  
 Humidity Range (non-condensing) ..... 0 to 95% Relative

**1.7.4 ELECTRICAL**

AC Supply Voltage Minimum ..... 80 Vac  
 AC Supply Voltage Maximum ..... 135 Vac  
 AC Supply Power Maximum..... 2.5 Watts  
 DC Inputs  
     True (low) ..... less than 8 Vdc  
     False (high) ..... greater than 12 Vdc  
 Optically Isolated Solid State Outputs  
     True (low, 50 mA) ..... less than 1.5 Vdc  
     False (high) ..... greater than 16 Vdc  
     Maximum Leakage Current (high) ..... less than 1 uA  
     Maximum Current ..... 50 mA  
     Collector Voltage Maximum ..... 50 Vdc

**1.7.5 TIMING**

Input Pulse Width Reject ..... less than 5 ms  
 Input Pulse Width Accept ..... greater than 25 ms

**1.7.6 CONNECTIONS**

Edge Connector mates with connector type Cinch 50-44A-30

PIN	FUNCTION
D	Input CH 1
E	Input CH 1 Common
F	CH 1 Output Collector
H	CH 1 Output Emitter
J	Input CH 2
K	Input CH 2 Common
L	Equipment Ground
M	AC -
N	AC +
W	CH 2 Output Collector

<b>PIN</b>	<b>FUNCTION</b>
X	CH 2 Output Emitter

1.8 PARTS LIST AND SCHEMATIC

Item	EDI Part Number	Qty	Description	Reference	Manufacturer
1	410-4148-S	8	DIODE, 1N4148WS, SMT SOD323	CR15-20 CR23-24	DIODES INC.
2	325-1010-500R	1	CAPACITOR, CER.DISCS, 100pF, 500V, 10%, RDL	C12	BC Components, D101K20Y5PL
3	325-4700-500R	1	CAPACITOR, CER.DISCS, 47pF, 500V, 10%, RDL	C11	BC Components, D470K20Y5PLAAEU
4	300-1070-035S	1	CAPACITOR, ELECTROLYTIC, 100uF, 35V, 20%, SMT,6.3	C7	NIC, NACE101M35V6.3X8TR1
			x 8		3
5	300-3370-035S	1	CAPACITOR, ELECTROLYTIC, 330uF, 35V, LOW ESR, 20%, SMT	C14	ILLINOIS 227AXZ016M
6	300-3370-035S	2	CAPACITOR, ELECTROLYTIC, 330uF, 35V, LOW ESR, 20%, SMT	C16-17	NICHICON UPL1V221MPH
7	300-3360-250R	1	CAPACITOR, ELECT, 33uF, 250WV, 20 %, RDL	C3	ILLINOIS 336CKR250M
8	335-1040-630R	2	CAPACITOR, 0.1UF, 630V, 10%, METALIZED FILM, 15mm	C5-6	Nissei, MMC104K630B
9	310-1060-006S	1	CAPACITOR, TANTALUM, 10UF, 6.3V, 20%, 1206 CHIP	C18	PANASONIC ECSTOJY106R
10	320-1020-050S	2	CAPACITOR, CER.MULT, 0.001uF, 50V, 10%, 1206 CHIP	C10 C13	SAMSUNG, CL31C102KBNNNC
11	320-1030-100S	1	CAPACITOR, CER.MULT, 0.01uF, 100V, 10%, 1206 CHIP	C8	Kemet, C1206C103K1RAC
12	320-1030-100S	1	CAPACITOR, CER.MULT, 0.01uF, 100V, 10%, 1206 CHIP	C9	
13	320-1040-050S	5	CAPACITOR, CER.MULT, 0.1uF, 50V, 10%, 1206 CHIP	C1-2 C15 C19-20	MERITEK, MA1206XR104K500
14	410-4755-S	2	DIODE, ZENER, CMZ5941B, 1.0W, 5%, 43V,SMA	CR1-2	Central Semiconductor
15		1	(NO COMPONENT)	J1	

## Model 242 Operations Manual

16	850-0047-S	1	INDUCTOR, 4.7uH, SMT 1210	L1	VISHAY-DALE,
					IMC1210SY4R7K
17		6	(NO COMPONENT)	GND HV+ HV- VCC VDD	
				V_UNF	
18		1	(NO COMPONENT)	SEL3	
19	255-0000-S	1		E4	
20	425-0319	2	DISPLAY, LED MODULE, DUAL, RA, HIGH BRIGHTNESS,	DS1-2	SUNLED,
			RED ONLY		XVG1L32WED22
21	780-0060	1		CVR1	Eberle Design
22	410-0140-S	1	DIODE, SCHOTTKY, MBR5140T3, 40V,1A, SMB	CR14	ON SEMI
23	440-7805-S	1	MC7805BD2T, 5V REG., 1A, D2PAK	VR1	ON Semi
24	430-0006-S	2	TRANSISTOR, MMBTA06LT1, NPN, 80V, 500 mA,SOT-23	Q1-2	ON Semi
25	440-0150	1	REGULATOR, METAL OXIDE VARISTOR, S14K150	RV7	MERITEK, TVR14241
26	440-0030	2	REGULATOR, METAL OXIDE VARISTOR	RV4-5	MERITEK, TVR14470
27		2	(NO COMPONENT)	M1-2	
28	410-0160-S	1	DIODE, ULTRAFast, MURA160T3, 600V,1A, SMA	CR10	ON SEMI
29	440-1051-S	1	REGULATOR, SWITCHING, OFFLINE	U1	ON SEMI
					NCP1051ST136T3
30	485-0687-S	1	PIC16F687-I/SS, PROC, 20PIN SSOP	U8	MICROCHIP
					PIC16F687-I/SS
31		1	PIC Programming Port	P1	
32	420-2811-S	3	OPTOCOUPLER, PS2801-1, 4 PIN SOP	U2 U4 U6	NEC PS2801-1
33	255-0000-S	4	RESISTOR, 1/8W, 0 OHMS, 5%, 1206 surface mount	E2 E6-7 E9	
34	255-1020-S	3	RESISTOR, 1/8W, 1K, 5%, 1206 surface mount	R21 R24 R32	
35	255-1030-S	2	RESISTOR, 1/8W, 10K, 5%, 1206 surface mount	R14-15	
36	255-1040-S	2	RESISTOR, 1/8W, 100K, 5%, 1206 surface mount	R22 R33	
37	251-1052-S	3	RESISTOR, 1/8W, 10.5K, 1%, 1206 surface mount	R11 R13 R30	
38	251-1211-S	1	RESISTOR, 1/8W, 1.21K, 1%, 1206 surface mount	R26	
39	251-1961-S	3	RESISTOR, 1/8W, 1.96K, 1%, 1206 surface mount	R12 R17 R31	
40	255-4310-S	1	RESISTOR, 1/8W, 430 Ohm, 5%, 1206 surface mount	R27	
41	255-4720-S	4	RESISTOR, 1/8W, 4.7K, 5%, 1206 surface mount	R1-2 R9 R29	

## Model 242 Operations Manual

42	255-4730-S	2	RESISTOR, 1/8W, 47K, 5%, 1206 surface mount	R19-20	
43	255-5110-S	2	RESISTOR, 1/8W, 510 Ohm, 5%, 1206 surface mount	R16 R18	
44	255-6210-S	2	RESISTOR, 1/8W, 620 Ohm, 5%, 1206 surface mount	R35 R37	
45	251-8061-S	1	RESISTOR, 1/8W, 8.06K, 1%, 1206 surface mount	R25	
46	215-5610-S	4	Resistor, 560 OHMS, 1/2W, 5%, 2010 surf. mnt.	R5-8	
47	220-5600-S	2	RESISTOR, 1W, 56 Ohm, 5%, 2512 SMD	R3-4	RMC, 1W56E24
48	410-4005-S	4	DIODE, S1K, 800 PIV, 1A	CR4-7	Micro Electronic
					Instrument, S1K
49	410-0053-S	2	DIODE, TRANS. SUPR., SMA5.0A, 5V, SMA	CR9 CR11	ON SEMI, 1SMA5.0AT3
50	410-1526-S	1	TRANSORB, SMCJ26A, 26V, 1500W	CR13	DIODES, INC.
51		1	(NO COMPONENT)	SW1	
52	610-0055	2	SWITCH, SPDT, ON-OFF-MOM, RIGHT ANGLE, GOLD	SW2-3	C&K 7101MD9ABE
			CONTACTS		
53	440-0431-S	1	REGULATOR, TL431AID, VOLTAGE REF., 1%, SO8	U5	TI, TL431AID
54	800-0140	1	TRANSFORMER, PCMT, OFFLINE, 2.5W	T1	TRANSTEK MAGNETICS
					TMP60543CT





