

State of New York Model 242-NY

DC Isolator Unit Operations Manual

SERIAL NUMBER: 0601XXXXX and up

PCB Issue B, 010-0242-001

REVISION: MAY 2006

pn 888-0242-005

Table of Contents

1.1 Glossary	1
1.2 General Description	1
1.3 General Characteristics	1
1.4 Installation and Adjustments	1
1.5 Theory of Operation	2
1.5.1 System Description	2
1.5.2 Input Circuit	2
1.5.3 MCU Circuit	2
1.5.4 Output Circuit	2
1.5.5 Display and Switch Circuit	3
1.5.6 Power Supply Circuit	3
1.6 Maintenance	3
1.6.1 Trouble Analysis	3
1.6.2 Trouble Shooting Sequence	3
1.7 Specifications	3
1.7.1 Construction	3
1.7.2 Mechanical	3
1.7.3 Environmental	4
1.7.4 Electrical	4
1.7.5 Timing	4
1.7.6 Connections	4
1.8 Parts List and Schematic	5

EBERLE DESIGN INC.

3510 East Atlanta Avenue Tel (480) 968-6407
Phoenix, AZ 85040 USA Fax (602) 437-1996
www.EDItraffic.com



THE MODEL 242-NY DC ISOLATOR UNIT IS DESIGNED AND MANUFACTURED IN THE USA
U.S. PATENT NO. 7,855,893 © COPYRIGHT 2006 EDI

1.1 GLOSSARY

A - Ampere

°C - Celsius

Component - Any electrical or electronic device

DC - Direct Current

Firmware – Program code embedded into a microcontroller unit

Hz - Hertz

IC - Integrated Circuit

Jumper - A means of connecting/disconnecting two or more conductive by soldering/desoldering a conductive wire or by PCB post jumper

LED - Light Emitting Diode

LOGIC - Negative Logic Convention (Ground True) State

mA - milliAmpere

ms - millisecond

MCU - Micro Controller Unit or microcontroller unit

MOV - Metal Oxide Varistor

Opto-coupler – An integrated circuit that provides electrical isolation

PCB - Printed Circuit Board

RMS - Root-Mean-Square

s – second

Schmittt Circuit – a circuit that provides hysteresis in the threshold

SW – Switch

uF - microfarad

VAC - Voltage Alternating Current

VDC - Voltage Direct Current

1.2 GENERAL DESCRIPTION

The Eberle Design Model 242-NY is a dual channel DC Isolator unit designed to meet *New York State Transportation Management Equipment Specifications*. The isolator unit occupies one position of a 170/179 standard input file. The isolator unit card incorporates a double-sided 44 pin edge connector for the connection of power, input, and output signals. Each channel has individual front panel controls for testing the operational mode, and high intensity front panel LEDs which are used to indicate the output state. Outputs are optically-isolated solid-state transistors.

1.3 GENERAL CHARACTERISTICS

Each channel of the Model 242-NY provides input hysteresis and digital filtering to qualify the input signal. An input signal must meet the minimum pulse requirements specified in section 1.7.5 in order to produce a valid output. The output pulse width for both channels can be set to 100 milliseconds minimum by installing jumper SEL3 or E3 (E3 is installed as factory default).

Both the input and output circuits have been designed for maximum protection from electrical transients. The inputs have been designed to withstand the discharge of a 10 uF capacitor charged to +/- 1000 Vdc directly across the input pins, and a discharge of a 10 uF capacitor charged to +/- 2000 Vdc applied through a source impedance of 5 ohms across the input pins or to Equipment Ground. The outputs are protected by a transient clamp diode.

The Model 242-NY handle assembly is made of GE Lexan™ Type 121, which is a super durable polycarbonate resin. The design of this assembly strengthens and protects the whole PCB assembly much better than conventional metal face plates.

1.4 INSTALLATION AND ADJUSTMENTS

Installation of the unit consists of plugging into the appropriate slot of the Input File and connecting the assigned inputs to the proper cabinet terminals. The edge connector is keyed to prevent incorrect installation. Following power-up, a front panel LED test will illuminate both OUT indicators for two seconds.

If desired, the output pulse width for both channels can be set to 100 milliseconds minimum by installing jumper SEL3 or E3 (E3 is installed as factory default).

1.5 THEORY OF OPERATION

Reference designators shown are for Channel 1. Reference designators for channel 2 are shown in parenthesis.

1.5.1 SYSTEM DESCRIPTION

The sensor circuitry can be broken down into seven major blocks. Each “Input Circuit” block contains the electrical transient devices and the input biasing circuit. Although the Model 242-NY has two DC inputs, a single digital processing section is used to process both inputs.

The microcontroller unit “MCU” Block provides the input voltage threshold and input pulse width filtering function on both channel 1 and channel 2 DC input circuits.

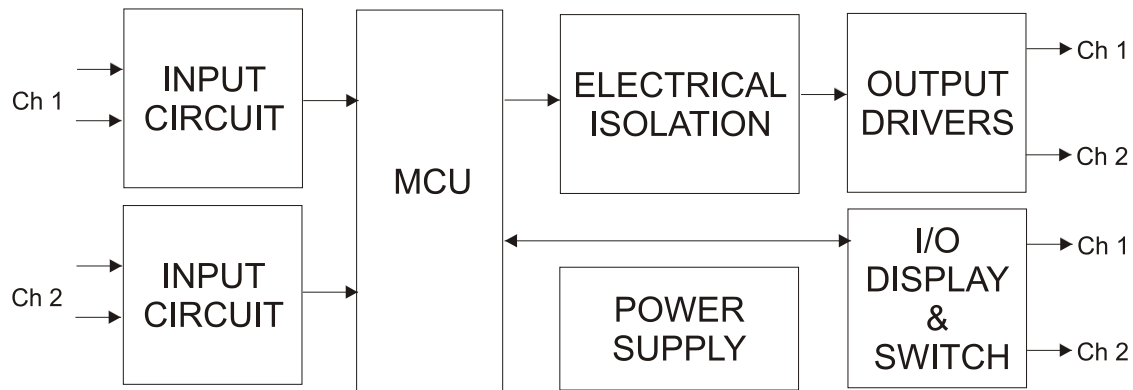

The MCU then controls the OUTPUT and DISPLAY blocks appropriately. If jumper SEL3 or E3 is installed a valid input pulse will generate an output pulse of 100 milliseconds minimum.

The microcontroller also reads the state of the TEST switches on the front panel. If the TEST switch is in the ON (locked) or MOM (momentary) position it will force the output to the asserted (True) state regardless of the input circuit state. The TEST switches are processed through the MCU for pulse width input and output requirements.

Valid output calls are made via optically isolated solid state transistors. Output calls are indicated on the front panel by means of high intensity LEDs labeled “OUT”.

The Model 242-NY operating voltage is supplied by the cabinet 24 Vdc power supply. The VDD supply for the microcontroller and display elements results from a post regulated 5 Vdc.

1.5.2 INPUT CIRCUIT

Resistors R5, R7, R11, and R12 (R6, R8, R13, and R17) provide the input bias and voltage scaling circuit. The resulting voltage at U8.8 (U8.9) is then processed by the microcontroller U8. Metal Oxide Varistor RV4 (RV5) provides input electrical transient protection.

1.5.3 MCU CIRCUIT

The microcontroller U8 processes the input voltages to perform the voltage threshold and pulse width filtering functions. All signal processing is performed in the digital domain and controlled by firmware embedded in the microcontroller. This unit does not rely on analog delay, pulse, or comparator circuits for processing the input signals.

1.5.4 OUTPUT CIRCUIT

The output driver Q2 (Q1) is isolated from both the AC Mains and the internal GND reference of the Model 242-NY by opto-couplers U6 (U2). CR1 (CR2) provides electrical transient protection for the output driver Q2 (Q1).

1.5.5 DISPLAY AND SWITCH CIRCUIT

The LED indicator DS1 (DS2) for the channel output is driven directly from the microcontroller U8. The input TEST switch SW4 (SW5) is read by the microcontroller U8 using strobe U8.19 (U8.18).

1.5.6 POWER SUPPLY CIRCUIT

The main power supply for internal logic VDD is a standard 7805 type 5.0 Vdc regulator (VR1). Diode CR13 provides for overvoltage protection on the input. Capacitors C16 and C17 provide bulk charge storage for holdup time.

1.6 MAINTENANCE

The Model 242-NY requires no adjustments or preventive maintenance.

1.6.1 TROUBLE ANALYSIS

The following list should be used to trouble-shoot the Model 242-NY installation. If the Model 242-NY unit itself is suspect, see Section 1.6.2 for a complete internal testing sequence.

- a. Neither channel responds to DC inputs
 - a. Power supply fault
The Model 242-NY requires a 24 Vdc nominal supply.
- b. Channel does not detect all inputs
 - a. Input voltage or pulse width does not meet the requirements of section 1.7.4 or 1.7.5.
Verify that the DC input voltage level is less than the DC Inputs True specification.
Verify that the DC input pulse width is greater than the Input Pulse Width Accept specification.

1.6.2 TROUBLE SHOOTING SEQUENCE

Apply 24 Vdc nominal power to DC+ pin J1-B referenced to DC- pin J1-A. Connect a jumper circuit to the DC inputs J1-D (J1-J) and J1-E (J1-K) to simulate the closure of the input contacts. The following signal measurements are referenced to test point "GND" J1-A.

- a. Input Bias Power Supply
Voltage at test point V_UNF should be 23 ± 1 Vdc.
Possible component faults are: CR12, R13, CR13, or VR1.
- b. Regulated Power Supply
Voltage at test point VDD should be 5 ± 0.2 Vdc.
Possible component faults are: voltage regulator VR1.
- c. Microcontroller
Waveform at pin 5 of P1 (or U8.18) should be a 2.5 us high to low pulse every 1 millisecond.
Possible components at fault are: microcontroller U8.
- d. Output Circuit
Output signals are processed by the microcontroller U8 and appear at U8.6 (U8.5) and on the display LEDs but are not appearing at the output pins.
Possible components at fault are: opto-coupler U6 (U2), output transistor Q2 (Q1).

1.7 SPECIFICATIONS

1.7.1 CONSTRUCTION

Printed circuit boards are double sided 2 oz. (56.70 gm.) copper with plated through holes. Circuit boards are coated for environmental protection.

1.7.2 MECHANICAL

Height 4.50 inches

Width 1.2 inches
 Depth (excluding handle) 6.875 inches

1.7.3 ENVIRONMENTAL

Storage Temperature Range..... -45 to +85 °C
 Operating Temperature Range -34 to +74 °C
 Humidity Range (non-condensing) 0 to 95% Relative

1.7.4 ELECTRICAL

DC Supply Voltage Minimum 18 Vdc
 DC Supply Voltage Maximum 28 Vdc
 DC Supply Current Maximum (DC Supply = 24 Vdc)..... 80 mA
 DC Inputs
 True (low) less than 8 Vdc
 False (high) greater than 12 Vdc
 Optically Isolated Solid State Outputs
 True (low, 50 mA) less than 1.5 Vdc
 False (high) greater than 16 Vdc
 Maximum Leakage Current (high) less than 1 uA
 Maximum Current 50 mA
 Collector Voltage Maximum 50 Vdc

1.7.5 TIMING

Input Pulse Width Reject less than 5 ms
 Input Pulse Width Accept greater than 25 ms

1.7.6 CONNECTIONS

Edge Connector mates with connector type Cinch 50-44A-30

PIN	FUNCTION
A	DC Ground
B	+24 VDC
D	Input CH 1
E	Input CH 1 Common
F	CH 1 Output Collector
H	CH 1 Output Emitter
J	Input CH 2
K	Input CH 2 Common
L	Equipment Ground
W	CH 2 Output Collector
X	CH 2 Output Emitter

1.8 PARTS LIST AND SCHEMATIC

Bill Of Materials for EDI 242-NY Iss B Rev A					

Item	EDI Part Number	Qty	Description	Reference	Manufacturer

1		1	(NO COMPONENT)	J1	
2		4	(NO COMPONENT)	GND VCC VDD V_UNF	
3		2		M1-2	
4		1	PIC Programming Port	P1	
5	215-1000-S	1	RESISTOR, 1/2W, 10 OHMS, 5%, 2010 surface mount	R23	
6	215-5610-S	4	Resistor, 560 OHMS, 1/2W, 5%, 2010 surf. mnt.	R5-8	
7	251-1052-S	3	RESISTOR, 1/8W, 10.5K, 1%, 1206 surface mount	R11 R13 R30	
8	251-1961-S	3	RESISTOR, 1/8W, 1.96K, 1%, 1206 surface mount	R12 R17 R31	
9	255-0000-S	1		E3	
10	255-0000-S	8	RESISTOR, 1/8W, 0 OHMS, 5%, 1206 surface mount	E1 E4-6 E8 E10-12	
11	255-1020-S	2	RESISTOR, 1/8W, 1K, 5%, 1206 surface mount	R21 R32	
12	255-1040-S	2	RESISTOR, 1/8W, 100K, 5%, 1206 surface mount	R22 R33	
13	255-4720-S	4	RESISTOR, 1/8W, 4.7K, 5%, 1206 surface mount	R1-2 R9 R29	
14	255-5110-S	2	RESISTOR, 1/8W, 510 Ohm, 5%, 1206 surface mount	R16 R18	
15	255-6210-S	2	RESISTOR, 1/8W, 620 Ohm, 5%, 1206 surface mount	R35 R37	
16	300-3370-035S	2	CAPACITOR, ELECTROLYTIC, 330uF, 35V, LOW ESR,	C16-17	NICHICON
			20%, SMT		UPL1V221MPH
17	310-1060-006S	1	CAPACITOR, TANTALUM, 10UF, 6.3V, 20%, 1206 CHIP	C18	PANASONIC
					ECSTOJY106R
18	320-1030-100S	2	CAPACITOR, CER.MULT, 0.01uF, 100V, 10%, 1206 CHIP	C8-9	
19	320-1040-050S	5	CAPACITOR, CER.MULT, 0.1uF, 50V, 10%, 1206 CHIP	C1-2 C15 C19-20	
20	410-0053-S	2	DIODE, TRANS. SUPR., SMA5.0A, 5V,SMA	CR9 CR11	MOTOROLA
21	410-1526-S	1	TRANSORB, SMCJ26A, 26V, 1500W	CR13	DIODES, INC.
22	410-4005-S	1	DIODE, S1K, 800 PIV, 1A	CR12	
23	410-4148-S	6	DIODE, 1N4148WS, SMT SOD323	CR15-20	DIODES INC.
24	410-4755-S	2	DIODE, ZENER, CMZ5941B, 1.0W, 5%, 43V,SMA	CR1-2	

Model 242-NY Operations Manual

25	420-2811-S	2	OPTOCOUPLER, PS2801-1, 4 PIN SOP	U2 U6	NEC PS2801-1	
26	425-0319	2	DISPLAY, LED MODULE, DUAL, RA, HIGH BRIGHTNESS,	DS1-2		
			RED ONLY			
27	430-0006-S	2	TRANSISTOR, MMBTA06LT1, NPN, 80V, 500 mA, SOT-23	Q1-2		
28	440-0030	2	REGULATOR, METAL OXIDE VARISTOR	RV4-5		
29	440-7805-S	1	MC7805BD2T, 5V REG., 1A, D2PAK	VR1	MOTOROLA	
30	485-0687-S	1	PIC16F687-I/SS, PROC, 20PIN SSOP	U8	MICROCHIP	
					PIC16F687-I/SS	
31	610-0055	2	SWITCH, SPDT, ON-OFF-MOM, RIGHT ANGLE, GOLD	SW2-3	C&K 7101MD9ABE	
			CONTACTS			
32	780-0060	1	COVER AND HANDLE ASSBLY	CVR1		
33	790-0242-004	1	242 FRONT LABEL, LARGE SWITCHES	CVR2		
34	NO COMPONENT	1	NO COMPONENT	SW1		

Model 242-NY Operations Manual

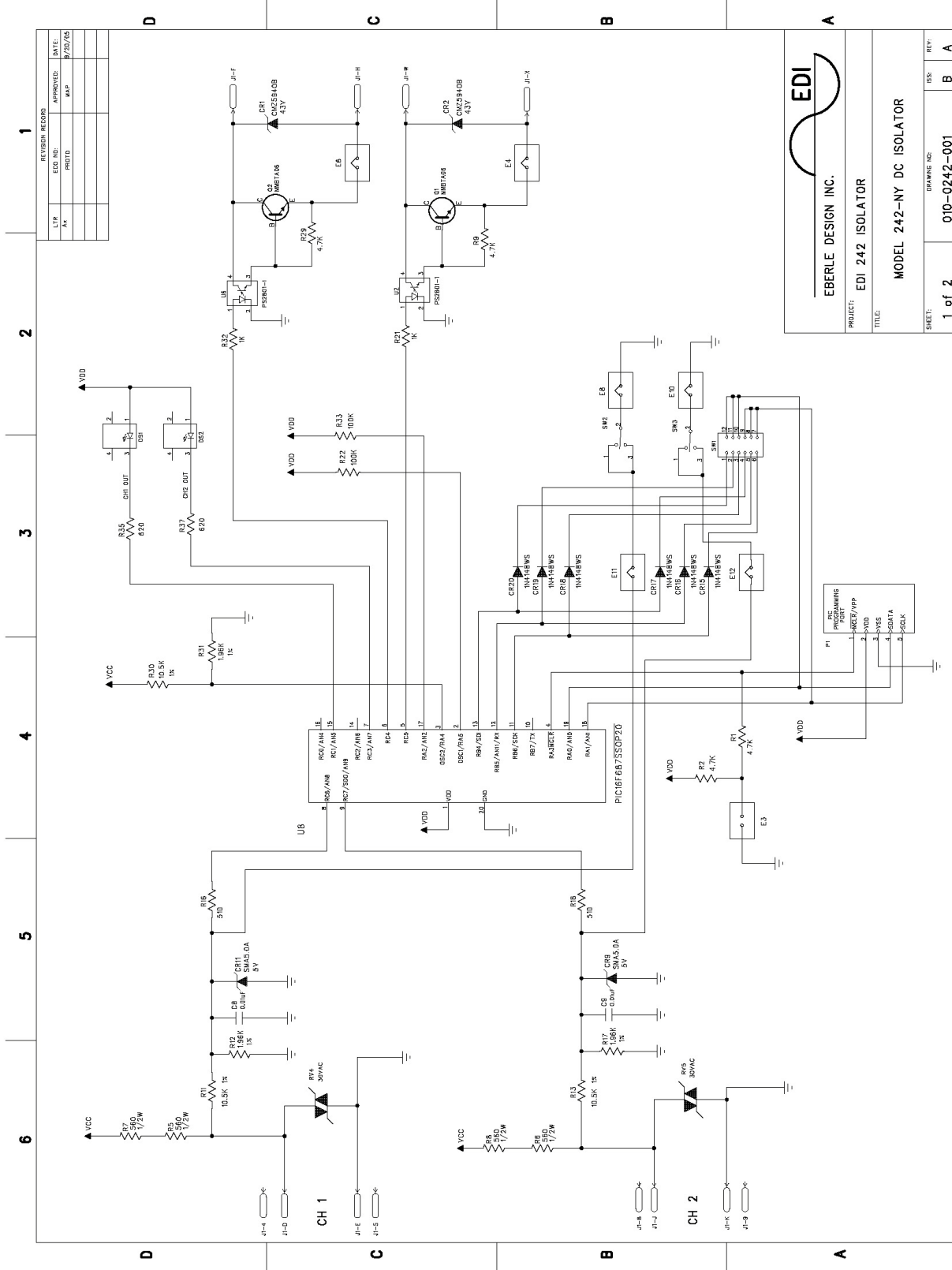

Model 242-NY Operations Manual

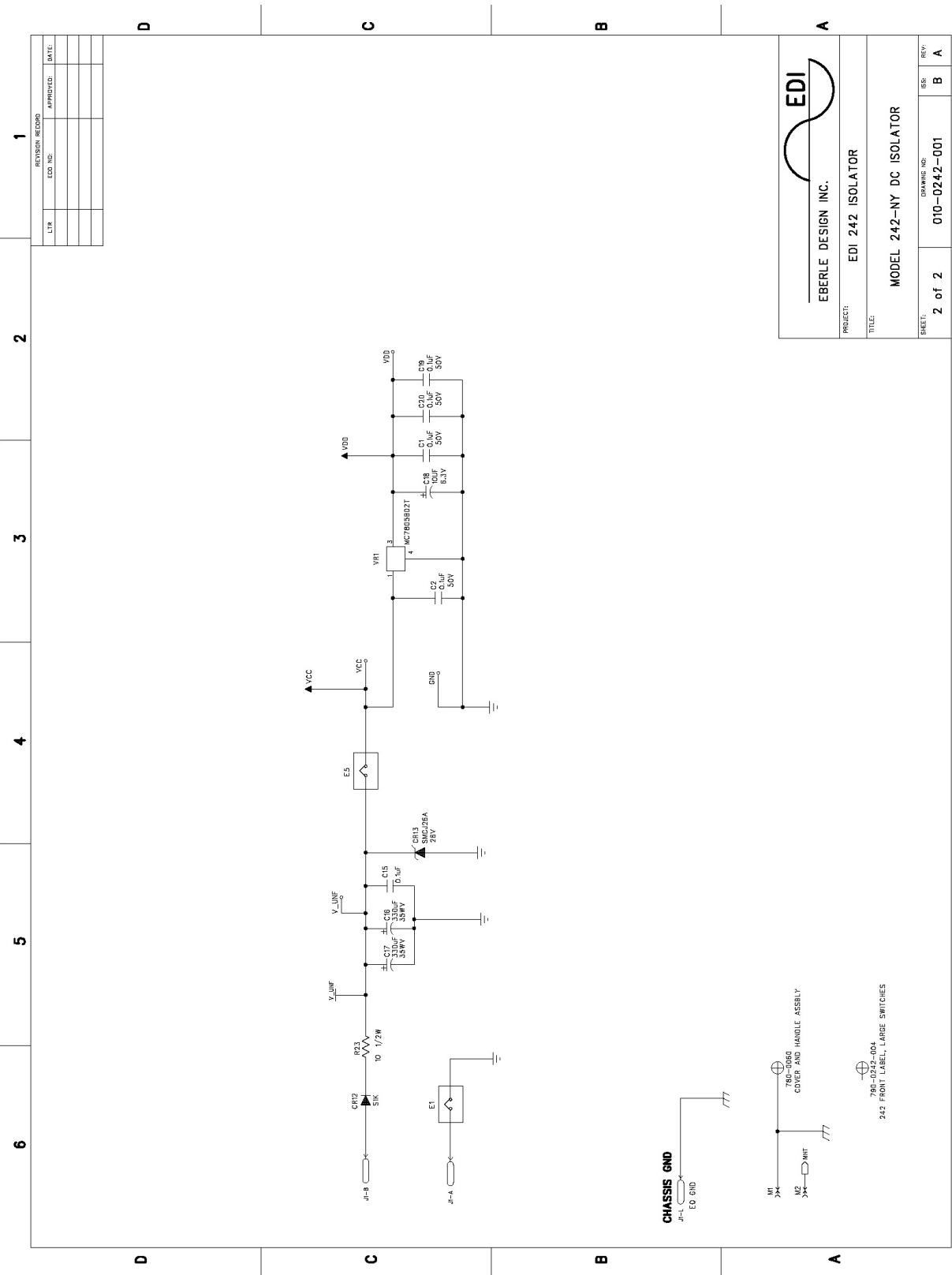

REVISION RECORD		
DATE	APPROVED	DATE

EDI
EBERLE DESIGN INC.

PROJECT: EDI 242 ISOLATOR
TITLE: MODEL 242-NY DC ISOLATOR

SHEET: 2 of 2 DRAWING NO: 010-0242-001 REV: B A

