

State of California Model 222

Inductive Loop Detector Sensor Unit Operations Manual

MODEL 222

SERIAL NUMBER: 0507XXXXX and up

PCB Issue B, 010-6222-001

REVISION: JULY 2005

pn 888-0222-001

Table of Contents

1.1 Glossary	1
1.2 General Description	2
1.3 General Characteristics	2
1.4 Installation and Adjustments	2
1.5 Loop Installation.....	3
1.6 Theory of Operation	4
1.6.1 System Description	4
1.6.2 Description of Circuit Operation	5
1.7 Maintenance	6
1.7.1 Trouble Analysis	6
1.7.2 Trouble Shooting Sequence Chart	6
1.8 Specifications	7
1.9 Parts List and Schematic	11

THE MODEL 222 SERIES INDUCTIVE LOOP DETECTOR SENSOR UNIT IS DESIGNED AND
MANUFACTURED IN THE USA BY EBERLE DESIGN INC., PHOENIX, ARIZONA.

U.S. PATENT NO. 7,855,893. © COPYRIGHT 2011 EDI

EBERLE DESIGN INC.

3510 East Atlanta Avenue
Phoenix, AZ 85040 USA
www.EDIttraffic.com

Tel (480) 968-6407
Fax (602) 437-1996



1.1 GLOSSARY

A - Ampere

°C - Celsius

Component - Any electrical or electronic device

Crosstalk – a symptom of interference between two adjacent loops running at similar frequencies

$\Delta L/L$ – Change of inductance divided by the nominal inductance

DC - Direct Current

DIP – Dual Inline Package

Firmware - A computer program or software stored permanently in PROM

FLASH – An IC Memory with nonvolatile, electrically erasable, programmable features

Hz - Hertz

IC - Integrated Circuit

Inductance - The property of an electric circuit by which an electromotive force is induced in it as the result of a changing magnetic flux

Jumper - A means of connecting/disconnecting two or more conductive by soldering/desoldering a conductive wire or by PCB post jumper

LED - Light Emitting Diode

LOGIC - Negative Logic Convention (Ground True) State

mA - milliAmpere

uH - microHenry

ms - millisecond

MCU - Micro Controller Unit

N.C. - Normally closed contact

N.O. - Normally open contact

Q Factor – A numerical rating for the quality of a resonant circuit. A higher number indicates lower losses.

PCB - Printed Circuit Board

RAM - Random Access Memory

RMS - Root-Mean-Square

ROM - Read Only Memory Device

s – second

Schmitt Circuit – a circuit that provides hysteresis in the threshold

SW – Switch

uF - microfarad

VAC - Voltage Alternating Current

VDC - Voltage Direct Current

1.2 GENERAL DESCRIPTION

The Eberle Design Model 222 is a dual channel inductive loop vehicle detector sensor unit designed to meet Caltrans specifications TSCES 1989, contract addendum of July 1991, and TEES August 2002 Chapter 1. The sensor unit occupies one position of a 170 standard input file. The sensor unit card incorporates a double-sided 44 pin edge connector for the connection of power, loops and call signals. Each channel has individual front panel controls for setting sensitivity, operational mode and frequency, and is equipped with high intensity front panel LEDs which are used to indicate the detect state. Call outputs are optically-isolated and solid-state transistors.

1.3 GENERAL CHARACTERISTICS

Each channel of the Model 222 will tune automatically to any loop and lead-in inductance between 20 and 2000 microhenries and will provide satisfactory operation with lead-ins up to 1000 feet in length. The unit will detect inductance changes as small as 0.01% $\Delta L/L$. Each channel is sequentially energized and sampled so as to negate the possibility of crosstalk between loops connected to different channels of the same detector. Short and consistent sample periods result in fast response times when operated in the lower sensitivity settings.

1.4 INSTALLATION AND ADJUSTMENTS

Setting up the Model 222 sensor unit:

- a. Make sure that the unit is pushed fully home in its position in the input file.
- b. Set the Sensitivity for each channel as required.

Sensitivity is set by moving the three DIP switches marked SENS to the desired position. Position 7 is the highest sensitivity, 0 is the lowest.

Sensitivity	$\Delta L / L$	SENS 4	SENS 2	SENS 1
Level 7	0.01%	ON	ON	ON
Level 6	0.02%	ON	ON	ON
Level 5	0.04%	ON	OFF	ON
Level 4	0.08%	ON	OFF	OFF
Level 3	0.16%	OFF	ON	ON
Level 2	0.32%	OFF	ON	OFF
Level 1	0.64%	OFF	OFF	ON
Level 0	1.28%	OFF	OFF	OFF

- c. Set the Operational Mode for each channel as required.

Operational mode can be set to presence or pulse mode. If presence mode is selected then short or long presence may be set. Use short presence unless the loop is expected to be continuously occupied for periods of time in excess of 30 minutes.

Mode	MODE 1	MODE 2	Max Duration
Pulse	PL	--	--
Short Presence	PR	SH	30 minutes
Long Presence	PR	LG	120 minutes

When the jumper labeled SEL3 is inserted, the Model 222 will limit the minimum presence time to 100 milliseconds.

- d. Set the Frequency for each channel as required.

Frequency setting needs to be changed only if interference occurs between adjacent loops connected to different sensor units. Interference or crosstalk may manifest itself

as chattering of the call output or a detect call occurring at the same time as an adjacent unit when there is no vehicle present. If crosstalk is suspected, try to separate the frequencies of the channels causing the problem. For example, set one to LOW (3) and the other to HIGH (0). Four frequency positions are available on each channel to assist in alleviating interference affecting more than two units.

Frequency	FREQ 1	FREQ 0
High	OFF	OFF
Med. High	OFF	ON
Med. Low	ON	OFF
Low	ON	ON

- e. If a channel is not to be used, it may be switched off (disabled) by setting the top DIP switch (switch 8) away from the ON setting.
- f. Check the front indicators. If both the DET and FLT indicators on a channel are flashing and no vehicles are present, there is a problem with the loop or the connections to the loop on that channel. Check the loop connections carefully.
 Note: Each channel may be reset by momentarily selecting channel OFF and then ON once more.
- g. Monitor operation and make adjustments to sensitivity and frequency as necessary.

1.5 LOOP INSTALLATION

The following are suggested guidelines for loop installation:

To begin, make sure that the pavement surface in the area in which the loops are to be installed is dry and free of debris. The outline of the loops should be marked on the pavement in such a way that the lines can be followed easily by the saw operator and not be erased by the water feed from the saw itself.

All 90 degree corners should be chamfered so that the course of the loop wire does not change direction sharply but rather at shallower angles of 45 degrees or less. Core drilling of the corners achieves the same effect but can still lead to failure due to sharp edges remaining in the corner area.

When the outline of the loop and lead-in has been marked, the pavement can be cut. Diamond blade cutting saws are recommended. The saw cut should be approximately 1.5 inches deep and 3/8" to 1/2" wide. The saw slot should then be cleaned and allowed to dry. Compressed air is useful both for ejecting debris and speeding up the drying process. All debris in the vicinity of the saw slot should also be removed so that it is not accidentally pushed back in.

Recommended loop wire is 14 gauge stranded copper wire with an insulating sheath of polypropylene type XLPE. IMSA specification 51-1 or 51-3 cable is suggested. Start laying the cable from the termination of the lead-in out towards the loop, continue around the loop for the number of turns required and finally return to the lead-in termination. When winding quadrupole loops ensure that the correct figure-of-eight configuration is maintained with the wires laid in the same direction in the center arm of the loop. Leave the lead-in cable out of the slot so that it may be twisted together before being laid in the slot.

As a general rule loops with circumference lengths less than 30 feet require 3 turns of wire, loops with greater circumference should have 2 turns. Lead-ins should be twisted with a minimum of 4 to 6 twists per foot to prevent any separation of the lead-in wires.

If long lead-ins are required, it is suggested that the loop cable be spliced onto shielded, pre-twisted, lead-in wire (IMSA spec 50-2 is suggested) at a convenient pull box location close to the loop. The shield may be connected to earth at the cabinet end but should then be insulated and isolated from earth ground at the loop end.

Make sure that the loop wire is pushed fully to the bottom of the saw slot. Small pieces of foam rubber or similar material may be used at various points around the circumference to prevent the loop wire from rising up while the sealant is poured.

Many different types of loop sealant are now available. Single part types are the easiest to apply since no mixing is required, but they also tend to be more expensive in terms of linear feet of saw slot filled. When applying the sealant, make sure that it is able to sink to the bottom of the slot and completely encase the loop wire. The wire should not be able to move when the sealant has set. Ensure that there is enough sealant to completely fill the slot; if possible the sealant should protrude slightly above the surface of the pavement so that small rocks or other debris cannot collect in the slot. The sealant manufacturer's instructions concerning setting time should be noted—especially when determining the length of time to wait before allowing vehicles to cross the loop area.

1.6 THEORY OF OPERATION

1.6.1 SYSTEM DESCRIPTION

The Model 222 works on the principle of measuring the period of a pre-determined number of cycles from an oscillator whose frequency is directly related to the inductance of the loop. The measurement is done by counting the number of cycles of a stable crystal oscillator reference that occur during the period to be measured. This scheme provides a high resolution measurement in a short period of time. Consecutive measurements are compared with a reference that has been established to determine whether or not the frequency of the loop oscillator has changed sufficiently to indicate the presence of a vehicle. Each channel is sequentially scanned so that only one loop oscillator is energized at any time.

The sensor circuitry can be broken down into four major blocks. The loop oscillators, digital processing circuitry, switch controls and the outputs/indicators. Each oscillator input incorporates a transformer to isolate the loop from the internal oscillator circuitry. Surge arrestors are provided to protect the unit from transient electrical damage. The Loop oscillator frequency may be modified to avoid crosstalk problems by switching capacitors into or out of the oscillator circuit. The output signals from the oscillators are fed through squaring circuits before being supplied to the digital processing circuit. Although the Model 222 has two loop oscillators, a single digital processing section is used to measure the period of both oscillators in sequence.

The microcontroller determines the requisite number of loop oscillator cycles over which to perform the measurement. It then provides this number to the digital processing section and a measurement is initiated. When the sample period has ended, the sample value is collected and processed by the microcontroller while another sample is initiated.

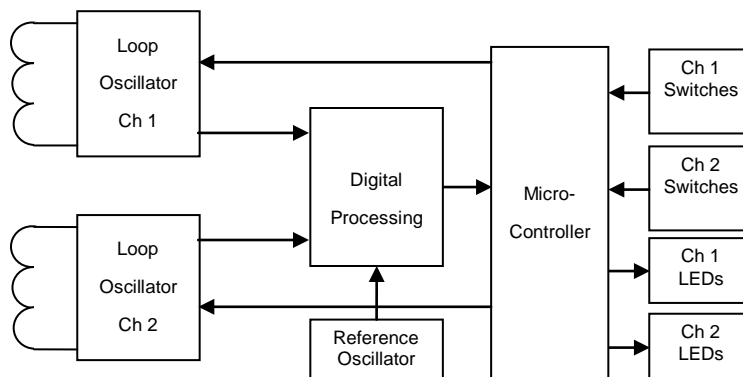

The microcontroller checks the sample to confirm that it is still within acceptable operating limits and then determines whether the sample has changed sufficiently with respect to the stored reference to indicate the presence of a vehicle. It then controls the output and indicator appropriately. Small changes in period which occur over a relatively long time are considered due to the environment and are tracked out by altering the stored reference. In this fashion, the

sensor unit can adjust for temperature changes and other long term effects such as the expansion and contraction of the pavement. The microcontroller maintains the time that a channel has been in the presence condition and will tune out a continuous presence after 30 minutes (Short Presence mode) or 120 minutes (Long Presence mode).

The microcontroller first determines the status of the front panel switches. The Operational mode determines whether the detection calls are to be momentary pulse or continuous. The Presence and the Sensitivity settings determine the length of the sample to ensure that the sensitivity will be sufficient to detect the desired types of vehicles and that the response time will be correct.

The microcontroller then begins the oscillator period measurement process by energizing the loop oscillator for the channel to be measured. During period measurement the digital processing circuit and the microcontroller count the number of cycles of the crystal based reference frequency.

When the sample period ends, the count is compared with a stored reference and detection decisions are made. Small changes which occur over a relatively long period of time are considered due to the changing environment, and the stored reference is modified accordingly by the microcontroller. Larger changes are deemed to be caused by the presence of a vehicle or vehicles and a detection signal is initiated.

Detection output calls are made via optically isolated transistors. These isolate the traffic controller input from the sensor unit circuitry. Output calls are indicated on the front panel by means of high intensity LEDs labeled "DET".

1.6.2 DESCRIPTION OF CIRCUIT OPERATION

The following description is valid for both channels of the Model 222. Reference designators are shown for channel 1 with those relating to channel 2 in parentheses.

Each loop oscillator is based upon two transistors, Q8 (Q9) and Q11 (Q13), loop transformer T1 (T2) and primary capacitor C12 (C11). The oscillator is enabled by transistor Q7-A (Q7-B). Frequency modification capacitors C16 and C18 (C13 & C17) are switched in via Q10-A (Q12-A) and Q10-B (Q12-B). Transient protection is provided by surge arrestor CR5 (CR6). When loops are connected to the loop input terminals and the unit is under power, the oscillators will attain their natural frequency according to the inductance of the loop and the capacitance which has been added via the frequency modification capacitors.

The oscillator output signal is found on the collector of Q8 (Q9) and is sine wave at the oscillator frequency (while the oscillator is energized). Zener diodes CR13 (CR14) are used to limit any voltage surges which may appear on the circuit side of the loop transformer.

The loop frequency signals from both of the oscillators are fed into Schmitt circuits U5A (U5B) to form square wave signals. The outputs of the Schmitt triggers are fed into the digital processing circuitry integrated into the microcontroller.

The digital processing circuit determines the period of a predetermined number of loop oscillator cycles and stores this value for retrieval by the microcontroller firmware. This value represents the period of the loop oscillator waveform to a very high precision.

Front panel switch settings are read directly by the microcontroller parallel ports P3 and P4. The Call Output opto-isolator U1 (U2) is driven directly by the microcontroller port P1_2 (P1_3). The front panel LED indicators DS1 (DS2) are similarly driven by the microcontroller port P5.

Monolithic regulator VR1 provides a stable 5 volt DC power supply to the digital circuitry and loop oscillators. The Model 222 will operate properly until the power input at pin J1-B drops below 8 VDC.

1.7 MAINTENANCE

1.7.1 TROUBLE ANALYSIS

The following list should be used to trouble-shoot the Model 222 installation. If the detector unit itself is suspect, see Section 1.7.2 for a complete internal testing sequence.

- a. Neither channel responds to vehicles.
 - a. Power supply fault.

The Model 222 requires a 24 VDC nominal supply. Each unit draws between 50mA and 80mA depending on detect status. The unit will operate at voltages as low as 8 Vdc, however, supply voltage below this may result in the unit entering a reset state. In this case, the unit will appear to be non-functional.
 - b. Reset line held low.

This fault is likely to affect all units in the rack since the external reset line is typically common to every rack position. Measure the voltage on the External Reset line (pin J1-C). If it is below 15 volts, remove each unit one by one until the next line returns to the power supply level. The unit that was removed last should be checked carefully for other faults. See Section 1.7.2.
- b. Channel does not detect all vehicles.
 - a. Sensitivity too low.

Increase sensitivity by one setting and observe detection.
- c. Channel is noisy or chatters and outputs false detect calls.
 - a. Two or more units are interfering with each other (crosstalk).

Check frequency settings on units which are connected to loops closest to the one exhibiting crosstalk; several may be showing signs of crosstalk themselves. Adjust the frequency switches on all units and all channels affected so that the largest possible margin exists between frequencies of loops positioned the closest.
 - b. Poor connections

Loop connections are very important to the satisfactory operation of the sensor unit. All connections whether they are in the cabinet or at the roadside must be secure, must be soldered and, in the case of connections made at the roadside, waterproofed to prevent shorting to ground.
 - c. Poor loops

Loops which have become degraded due to the passage of traffic may cause the unit to exhibit crosstalk like symptoms. It may be possible to reduce the sensitivity while maintaining adequate detection of vehicles. However, the ideal solution is to replace the loop.

1.7.2 TROUBLE SHOOTING SEQUENCE CHART.

Apply 24 VDC power to the unit (pin J1-B) referenced to Logic Ground (pin J1-A). Connect 100 microhenry inductors to the loop inputs pins J1-D (J1-J) and J1-E (J1-K) to simulate the connection of loops. The following signal measurements are referenced to Logic Ground (pin J1-A):

- a. Unregulated Power Supply.

Voltage at test point V_UNREG should be 24 ± 1 Vdc.

Possible component faults are: diode CR11, resistor R7, capacitors C6-C7, or voltage regulator VR1.

b. Regulated Power Supply.

Voltage at test point VDD should be 5 ± 0.2 Vdc.

Possible component faults are: voltage regulator VR1.

c. Microcontroller Clock.

Waveform at pin 6 of U4 should be a square wave at 22.118 MHz.

Possible components at fault are: Crystal XTL1, U4.

d. Reset Input to Microcontroller.

Voltage at pin 35 of U3 should be less than 0.5 Vdc.

Possible components at fault are: U5-D, U4-C, microcontroller U3.

e. Loop Oscillator Output.

Connect one channel of a dual channel oscilloscope to test point ENABLE1 (ENABLE2). Select trigger on the rising edge of this signal. Using the other channel of the oscilloscope, monitor test point LP1 (LP2). The signal should be as follows:

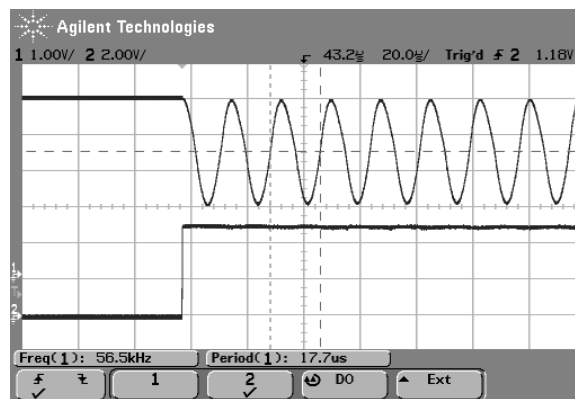

Repeat the above for the second loop detector channel. If the above waveform is not found on one or both channels of the detector, possible fault areas are Q8 (Q9), Q11 (Q13), Q7-A (Q7-B), CR13 (CR14), or T1 (T2).

f. Outputs and Indicators.

Monitor the outputs so that when the channel is in the detect state, the outputs can be seen to be conducting. Enter a detect condition by bringing an aluminum or similar non-ferromagnetic object close to each simulated loop. The DET indicator should illuminate and the opto-isolated output U1 (U2) should be conducting.

Possible components at fault are: opto-isolator U1 (U2), CR2 (CR7), or LED DS1 (DS2).

1.8 SPECIFICATIONS

Power Supply:

24 VDC \pm 20%, 80mA maximum, 40mA quiescent.

Loop Input:

The loop inputs incorporate transient protection devices and the loop oscillator circuitry is transformer isolated. The transient protection will withstand the discharge of a 10uF

capacitor charged to 2,000V across the loop inputs or between any loop input and earth ground. The transformer isolation allows operation with loops which may be grounded at a single point.

Tuning:

Each channel of the Model 222 will automatically tune to any loop and lead-in combination within the 20 to 2000 microhenry tuning range (Q factor greater than 5) upon application of power or when a valid reset signal is received. A channel may be retuned by adjusting mode, sensitivity or frequency.

Lead-in Length:

The unit will operate with lead-in (feeder) lengths over 1,000 feet with appropriate loops and proper lead-in cable.

Environmental Tracking:

The Model 222 automatically and continuously compensates drift and environmental effects throughout the tuning range and across the entire temperature range.

Grounded Loop Operation:

The Model 222 will operate when connected to poor quality loops including those that have a short to ground at a single point.

Sequential Scanning:

Only one channel is energized at any given time, thus reducing the possibility of crosstalk between adjacent loops connected to the same unit.

Fault Monitoring :

The Model 222 Loop Monitor™ continuously checks the integrity of the loop. The system is able to detect shorted or open circuit loops, or sudden changes in inductance exceeding 25% of the nominal value. If a fault is detected on a channel, the DET and FLT indicators will flash. The channel output will remain in the detect (call) state.

- i. One flash indicates an open circuit or a loop inductance exceeding the upper limit of the tuning range.
- ii. Two flashes indicate a short circuit or a loop inductance exceeding the lower limit of the tuning range.
- iii. Three flashes indicate that a sudden change in inductance exceeding 25% $\Delta L/L$ has occurred.

If the fault condition is removed, the DET indicator and the channel output will return to normal operation. The FLT indicator will continue to flash indicating that a fault had previously occurred.

High Intensity LED Indicators:

Each channel is fitted with a high intensity RED detect LED indicator (DET) and a Yellow Fault LED indicator (FLT).

Front Panel Controls:

Front panel mounted DIP switches allow the user to set up sensitivity, operational mode, frequency and channel OFF/ ON state independently for each channel.

Sensitivity:

One of eight settings may be selected to optimize detection on varying loop and lead-in configurations. Sensitivity is stated in terms of $\Delta L/L$, i.e. the minimum percentage change in the total inductance (loop plus lead-in) to which the unit will respond at the given level setting.

SENS	$\Delta L / L$	SENS	$\Delta L / L$
Level 7	0.01%	Level 3	0.16%
Level 6	0.02%	Level 2	0.32%
Level 5	0.04%	Level 1	0.64%
Level 4	0.08%	Level 0	1.28%

Channel ON/OFF:

Selecting Channel OFF will disable the channel. In this condition, the loop oscillator is de-energized, and the output will remain in the no-call state.

Operational Modes:

Pulse Mode (PL): 125 ± 25 milliseconds momentary output

Short Presence (SH): 30 minutes maximum

Long Presence (LG): 120 minutes maximum

When the jumper labeled SEL3 is inserted, the Model 222 will limit the minimum presence time to 100 milliseconds.

When operating in pulse mode, a vehicle remaining over a loop will inhibit further pulse outputs from being issued for a period of 2 seconds after which time vehicles passing over the uncovered portion of the loop will be detected.

Frequency:

One of four settings may be selected to alleviate interference which may occur when loops connected to different detectors are located adjacent to one another.

Reset Input:

The Model 222 may be reset by applying a ground true logic level to the Reset input pin J1-C.

Response Times:

The following are typical response times at different sensitivity levels. Note: the times indicated are valid when both channels are set to the same sensitivity operating at approximately 40KHz.

SENS	Response Time	SENS	Response Time
Level 7	40 ± 15 ms	Level 3	2.8 ± 1 ms
Level 6	19 ± 7 ms	Level 2	2.5 ± 1 ms
Level 5	9 ± 3 ms	Level 1	2.5 ± 1 ms
Level 4	5 ± 1.5 ms	Level 0	2.5 ± 1 ms

Output Ratings:

Optically Isolated Output Versions: The output transistor is rated for a maximum collector voltage of 50 Vdc. Transient protection is provided by 43 Vdc clamps. Maximum collector current is 50mA. In the saturated condition the collector voltage will be less than 1.5 Vdc with a collector current of 50mA. Maximum off state leakage current is 1 microampere. Isolation exceeds 5000 VAC.

Mechanical:

Dimensions: 1.12" Width x 4.5" Height x 7.0" Length (Excluding Handle)

Weight: 5 oz.

Environmental:

Temperature Range:

Storage: -45°C + 85°C (-50°F to 185°F)

Operating: -37°C to +74°C (-35°F to 165°F)

Humidity: 0 to 95% relative

Connections:

Edge Connector mates with connector type Cinch 50-44A-30.

PIN	FUNCTION
A	Logic Ground
B	+24 VDC
C	Reset
D & 4	Loop Input CH 1
E & 5	Loop Input CH 1
F	CH 1 Output Collector
H	CH 1 Output Emitter
J & 8	Loop Input CH 2
K & 9	Loop Input CH 2
L	Chassis Ground
W	CH 2 Output Collector
X	CH 2 Output Emitter

Note: Pins M & 11, N & 12, P & 13, R & 14, S & 15, T & 16, U & 17, V & 18, Y & 21, Z & 22 have no connection.

1.9 PARTS LIST AND SCHEMATIC

Bill Of Materials for LM222 Production Issue B				

Item	EDI Part Number	Qty	Description	Reference

1		1	(NO COMPONENT)	J1
2		10	(NO COMPONENT)	ENABLE1-2 GND LOOP1-2 LP1-2 TEST
				VDD V_UNREG
3		1	(NO COMPONENT)	SEL3
4		2		M1-2
5	215-1000-S	1	RESISTOR, 1/2W, 10 OHMS, 5%, 2010 surface mount	R13
6	255-0000-S	5	RESISTOR, 1/8W, 0 OHMS, 5%, 1206 surface mount	E1 R2 R4 R9 R12
7	255-1020-S	4	RESISTOR, 1/8W, 1K, 5%, 1206 surface mount	R8 R14 R29 R31
8	255-1040-S	4	RESISTOR, 1/8W, 100K, 5%, 1206 surface mount	R10 R37 R41 R46
9	255-1060-S	1	RESISTOR, 1/8W, 10M, 5%, 1206 surface mount	R33
10	255-2730-S	2	RESISTOR, 1/8W, 27K, 5%, 1206 surface mount	R17-18
11	255-4720-S	15	RESISTOR, 1/8W, 4.7K, 5%, 1206 surface mount	R1 R5 R15-16 R20 R23 R25 R28 R34
				R36 R39-40 R42-43 R47
12	255-5610-S	2	RESISTOR, 1/8W, 560, 5%, 1206 surface mount	R21 R26
13	255-5640-S	3	RESISTOR, 1/8W, 560K, 5%, 1206 surface mount	R35 R38 R45
14	255-6210-S	4	RESISTOR, 1/8W, 620 Ohm, 5%, 1206 surface mount	R48-51
15	255-6800-S	2	RESISTOR, 1/8W, 68, 5%, 1206 surface mount	R22 R27
16	255-6820-S	3	RESISTOR, 1/8W, 6.8K, 5%, 1206 surface mount	R19 R24 R32
17	300-2270-016S	2	CAPACITOR, ELECT,220uF,16WV, 20 %, LOW ESR,6.3mm	C10 C20
			SM	
18	300-3370-035S	2	CAPACITOR, ELECTROLYTIC, 330uF, 35V, LOW ESR,	C6-7
			20%, SMT	
19	320-1020-050S	2	CAPACITOR, CER.MULT, 0.001uF, 50V, 10%, 1206 CHIP	C8-9

Model 222 Operations Manual

20	320-1040-050S	11	CAPACITOR, CER.MULT, 0.1uF, 50V, 10%, 1206 CHIP	C1-3 C13-14 C19 C21-22 C24 C27-28
21	320-2200-050S	2	CAPACITOR, CER.MULT, 22pF, 50V, 10%, 1206 CHIP	C25-26
22	320-3910-050S	1	CAPACITOR, CER.MULT, 390pF, 50V, 10%, 1206 CHIP	C23
23	330-1040-016S	2	CAPACITOR, 0.1uF, 5%, POLYPHENYLENE SULFIDE FILM,	C11-12
			16VDC, 1210	
24	330-2230-016S	2	CAPACITOR, 0.022uF, 5%, POLYPHENYLENE SULFIDE	C15-16
			FILM, 16VDC, 1206	
25	330-4730-016S	2	CAPACITOR, 0.047uF, 5%, POLYPHENYLENE SULFIDE	C17-18
			FILM, 16VDC, 1206	
26	405-3302-S	1	IC, LM3302N, QUAD COMPARATOR, SO14	U5
27	410-0050-S	2	DIODE, TRANSORB,SMBJ5.0CA,SMT	CR13-14
28	410-4005-S	2	DIODE, S1K, 800 PIV, 1A	CR10-11
29	410-4755-S	2	DIODE, ZENER, CMZ5941B, 1.0W, 5%, 43V,SMA	CR2 CR7
30	420-2811-S	2	OPTOCOUPLER, PS2801-1, 4 PIN SOP	U1-2
31	425-0318	2	DISPLAY, LED MODULE, DUAL, RA, HIGH BRIGHTNESS	DS1-2
32	430-0006-S	2	TRANSISTOR, MMBTA06LT1, NPN, 80V, 500 mA,SOT-23	Q3 Q5
33	430-3904-S	2	TRANSISTOR, MMBT3904LT1, NPN, SOT-23	Q11 Q13
34	430-3906-S	2	TRANSISTOR, PNP, MMBT3906LT1, SOT23	Q8-9
35	430-7313-S	3	Transistor, Dual N Channel FET, IRF7313, SO8	Q7 Q10 Q12
36	440-1002-S	2	GAS DISCHARGE TUBE	CR5-6
37	440-7805-S	1	MC7805BD2T, 5V REG., 1A, D2PAK	VR1
38	485-7643-S	1	MICROCONTROLLER, CY8C27643-24PVI	U3
39	490-1000-S	1	IC, 74VHC00, QUAD 2-INPUT NAND GATE, SO14	U4
40	520-0105-P	1	CONECTOR, HEADER, 5-PIN, ISSP PORT	J2
41	630-1080	2	SWITCH, DIP-SWITCH, 8 POS, RT. ANGLE	SW3-4
42	651-2212-S	1	CRYSTAL, 22.118 MHZ, 20pF, AT CUT, HC49, SMT	XTL1
43	780-0060	1		CVR2
44	800-0116-S	2	TRANSFORMER,LOOP, RM6, SMT	T1-2

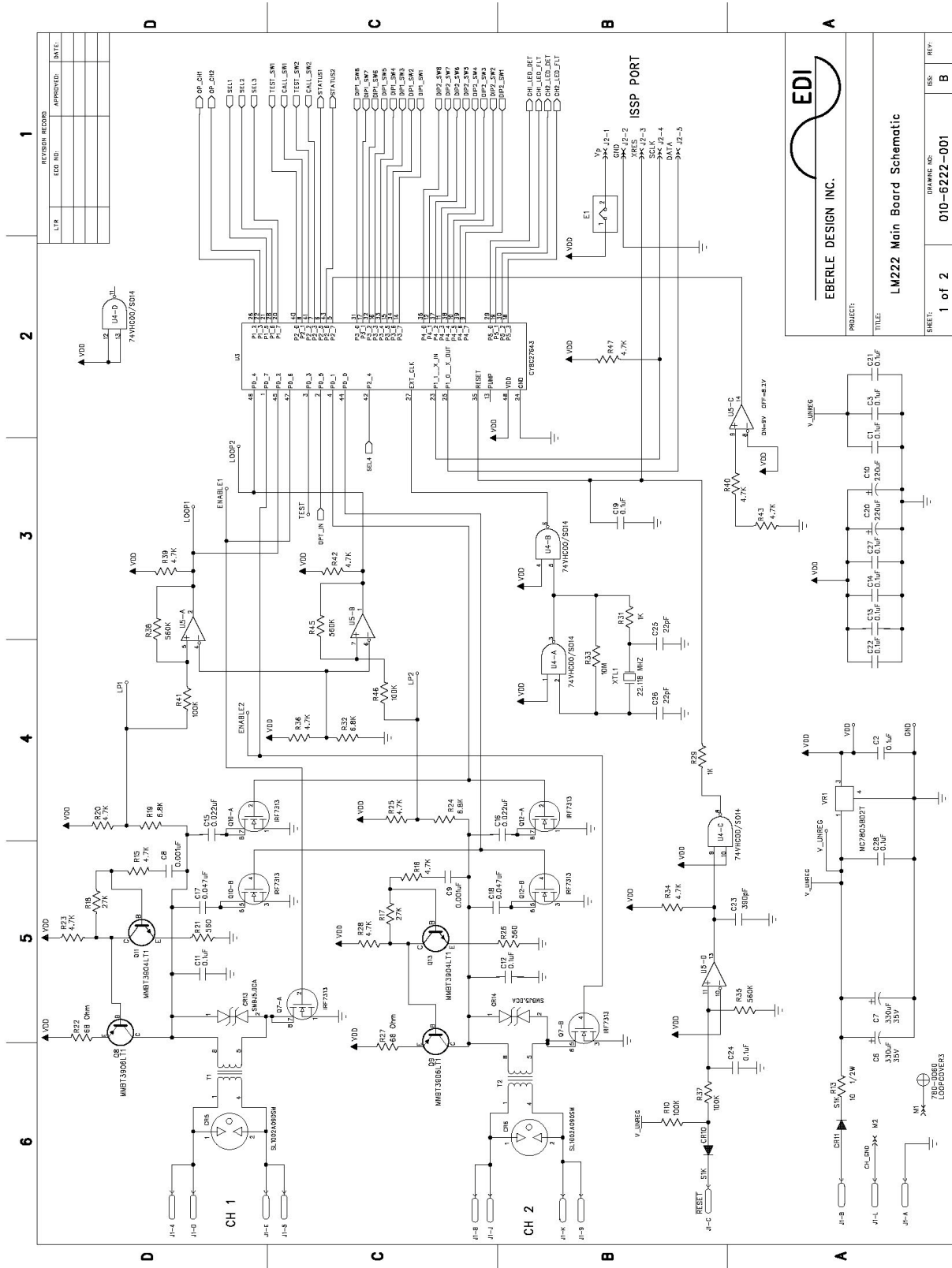



EBERLE DESIGN INC.

PROJECT:	ISS: B
TITLE:	LM222 Main Board Schematic
SHEET: 1 of 2	DRAWING NO: 010-6222-001

