

# CMU-212

## Cabinet Monitor Unit Operations Manual

THIS MANUAL CONTAINS TECHNICAL INFORMATION FOR THE CMU-212 SERIES ITS CABINET MONITOR UNIT. INCLUDED ARE GENERAL DESCRIPTION, OPERATIONAL DESCRIPTION, INSTALLATION, AND SPECIFICATIONS.

**THE CMU-212 SERIES CABINET MONITOR UNIT IS DESIGNED AND MANUFACTURED IN THE USA BY EBERLE DESIGN INC., PHOENIX, ARIZONA. EDI IS CERTIFIED TO ISO 9001:2008 QUALITY SYSTEMS STANDARDS.**

INFORMATION CONTAINED HEREIN IS PROPRIETARY TECHNICAL INFORMATION OF EBERLE DESIGN INC. PUBLICATION, REPRODUCTION OR USE IN WHOLE OR PART IS NOT PERMITTED EXCEPT UNDER TERMS AGREED UPON IN WRITING. © COPYRIGHT 2011 EDI.

REVISION: JULY 2011  
pn 888-0212-001



EBERLE DESIGN INC.

3510 East Atlanta Avenue  
Phoenix, AZ 85040 USA  
www.EDITraffic.com

Tel (480) 968-6407  
Fax (602) 437-1996



<blank>

### **MAINTENANCE NOTE**

**THIS EBERLE DESIGN INC. CABINET MONITOR UNIT HAS BEEN CAREFULLY INSPECTED AND TESTED TO ENSURE PROPER OPERATION. IT IS RECOMMENDED THAT THE CABINET MONITOR UNIT BE TESTED AT LEAST ANNUALLY TO ENSURE PROPER OPERATION AND COMPLIANCE WITH FACTORY SPECIFICATIONS.**

<blank>

## Table of Contents

<b>SECTION 1 GENERAL</b> .....	<b>1</b>
1.1 Overview.....	1
1.2 Channel Configuration .....	1
1.3 Auxiliary Monitor Unit .....	1
1.4 CMU-212 Programming .....	2
1.5 Detailed CMU Status.....	2
1.5.1 ECCOM SOFTWARE INTERFACE.....	2
1.5.2 AUXILIARY DISPLAY UNIT .....	3
1.6 Serial Bus #1 .....	3
1.6.1 SERIAL BUS #1 MESSAGE TYPES .....	3
1.7 Serial Bus #3 .....	3
1.7.1 SERIAL BUS #3 MESSAGE TYPES .....	3
1.8 Failed State Action (LFSA, LFSA-R, NFSA) .....	4
1.8.1 EXIT FROM FSA .....	4
<b>SECTION 2 MONITOR FUNCTIONS</b> .....	<b>5</b>
2.1 Cabinet Power Supply Monitor .....	5
2.2 Conflicting Channels Monitor.....	5
2.3 Serial Bus Monitor.....	5
2.3.1 SERIAL BUS #1 ERROR .....	5
2.3.2 SERIAL BUS #3 ERROR .....	5
2.4 Type 62 FSA Message.....	6
2.5 Lack of Signal Inputs Monitor .....	6
2.6 Multiple Input Monitor.....	6
2.7 Yellow Clearance Monitor .....	6
2.8 Yellow Plus Red Clearance Monitor .....	7
2.9 Local Flash Status .....	7
2.9.1 LOCAL FLASH STATUS RECOVERY .....	7
2.10 Circuit Breaker Trip Status .....	7
2.11 Flasher Unit Output Failed Alarm .....	7
2.12 CMU Power Failure.....	7
2.12.1 AC+ RAW LEVEL SENSE .....	8
2.12.2 POWER INTERRUPT .....	8
2.12.3 POWER RECOVERY .....	8
2.12.4 POWER UP.....	8
2.12.5 MINIMUM FLASH INTERVAL .....	8
2.13 Field Output Check .....	8
2.13.1 FIELD CHECK MODE.....	8
2.13.2 FIELD CHECK STATUS .....	9
2.14 Diagnostic Error .....	9
2.14.1 RAM MEMORY DIAGNOSTIC.....	9
2.14.2 NONVOLATILE MEMORY DIAGNOSTIC .....	9
2.14.3 DATAKEY MEMORY DIAGNOSTIC.....	9
2.14.4 INTERNAL MPU MONITOR.....	9
2.15 Recurrent Pulse Detection.....	9
2.15.1 RECURRENT PULSE DETECTION DISABLE .....	10
<b>SECTION 3 INPUT SIGNALS</b> .....	<b>11</b>
3.1 Field Signal Inputs .....	11
3.2 Load Switch Current.....	11
3.3 PDA Control Signal Inputs.....	11

3.3.1	LOCAL FLASH STATUS.....	11
3.3.2	MAIN CONTACTOR (MC) COIL STATUS.....	11
3.3.3	MAIN CONTACTOR (MC) SECONDARY STATUS.....	11
3.3.4	FTR COIL DRIVE STATUS.....	12
3.3.5	CIRCUIT BREAKER (CB) TRIP STATUS.....	12
3.3.6	FRONT / REAR DOOR SWITCH.....	12
3.4	Monitor Interlock.....	12
3.5	External Test Reset input.....	12
3.6	Serial Bus #1 Address Inputs.....	12
3.7	Serial Bus #1 Disable input.....	13
3.8	PDA Temperature.....	13
<b>SECTION 4 FRONT PANEL DESCRIPTION .....</b>		<b>14</b>
4.1	Indicators.....	14
4.1.1	POWER INDICATOR.....	14
4.1.2	24VDC FAIL INDICATOR.....	14
4.1.3	12VDC FAIL INDICATOR.....	14
4.1.4	CONFLICT INDICATOR.....	14
4.1.5	LACK OF SIGNAL INDICATOR.....	14
4.1.6	MULTIPLE INDICATOR.....	14
4.1.7	CU / LOCAL FLASH INDICATOR.....	14
4.1.8	CLEARANCE INDICATOR.....	14
4.1.9	FIELD CHECK INDICATOR.....	14
4.1.10	SB #1 ERROR INDICATOR.....	14
4.1.11	SB #3 ERROR INDICATOR.....	15
4.1.12	DIAGNOSTIC INDICATOR.....	15
4.1.13	SB #1 RX INDICATOR.....	15
4.1.14	SB #3 RX INDICATOR.....	15
4.2	Terminal Port.....	15
4.3	Reset Button.....	15
4.4	Datakey.....	15
<b>SECTION 5 SPECIFICATIONS .....</b>		<b>16</b>
5.1	Electrical.....	16
5.2	Timing.....	16
5.3	Mechanical.....	17
5.4	Environmental.....	17
<b>SECTION 6 CONNECTOR ASSIGNMENTS.....</b>		<b>18</b>
6.1	Main DIN Connector.....	18
6.2	EIA-232 Connector.....	18
6.3	CMUip-212 Ethernet LAN Port.....	19
6.3.1	ETHERNET LAN CABLE.....	19

## Section 1 GENERAL

### 1.1 OVERVIEW

The model CMU-212 Cabinet Monitor Unit (CMU-212) is the principle part of the ITS Traffic Control Cabinet Monitoring System. It is resident in the Power Distribution Assembly and communicates with an Auxiliary Monitor Unit (AMU) located in each Output Assembly via Serial Bus #3. The role of the CMU-212 is to query various cabinet conditions and, if the application requires action, the CMU-212 will transfer control from the Advanced Traffic Controller (ATC) to a flashing control mode. Applications include the detection of, and response to, improper and conflicting signals and improper operating voltages in a cabinet assembly caused by malfunctions of the (ATC), load switches, or miss wiring of the cabinet.

The communications between the ATC and the CMU-212 via Serial Bus #1 plays an integral role in ensuring safe and proper operation of the cabinet equipment as well as providing important diagnostic functions used for trouble shooting malfunctioning equipment.

The Eberle Design CMU-212 meets with or exceeds all specifications outlined the ASHTO/ITE/NEMA *Intelligent Transportation System (ITS) Standard Specification for Roadside Cabinets Version 01.02.17b* document.

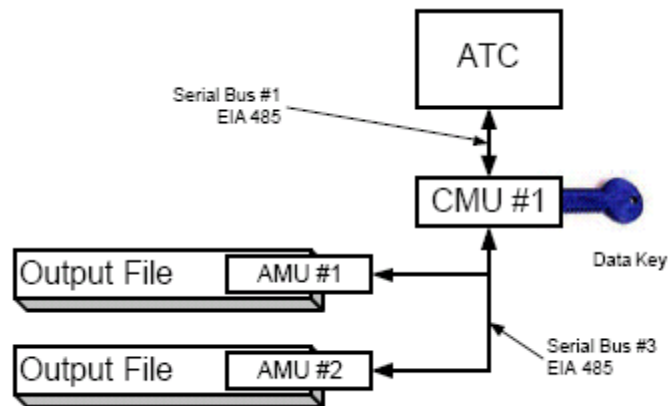

### 1.2 CHANNEL CONFIGURATION

The CMU-212 can be configured to monitor up to 28 physical load switch channels of three inputs per channel. An additional four virtual channels can be programmed to provide a total of 32 logical channels. Each channel is comprised of a Red / Don't Walk input, a Yellow input, and a Green / Walk input.

### 1.3 AUXILIARY MONITOR UNIT

The Auxiliary Monitor Unit (AMU-214) provides the CMU-212 with voltage and current measurements from each installed Output Assembly. The AMU-214 has the capability to measure and report field terminal voltages for fourteen channels of three inputs per channel and load currents for fourteen channels. The AMU-214 is also compatible with a six position Output Assembly. The AMU is configured by its output assembly address. This address is set by a jumper plug located on the rear of the output assembly. For further information concerning the AMU-214, see the Eberle Design *AMU-214 Operations Manual*.

The AMU-214 address assignment specifies the physical arrangement of the Output Assemblies. This defines the number of *contiguous* channels that the CMU-212 is monitoring. An AMU-214 assigned as a 14 channel unit must be addressed as AMU #1 with AMU #2 reserved, or as AMU #3 with AMU #4 reserved. The following table shows the ten possible cabinet configurations:

AMU #1	AMU #2	AMU #3	AMU #4	Monitored Channels
14	reserved	none	None	1 thru 14
14	reserved	14	reserved	1 thru 28
14	reserved	6	None	1 thru 20
14	reserved	6	6	1 thru 26
6	none	none	None	1 thru 6
6	6	none	None	1 thru 12
6	6	6	None	1 thru 18
6	6	6	6	1 thru 24
6	none	14	reserved	1 thru 20
6	6	14	reserved	1 thru 26

**The ATC must verify that all output assemblies being driven by a Serial Interface Unit (SIU) are being monitored by an AMU-214 and that the AMU-214 is enabled by the programming in the CMU-212. Failure to provide this check may result in unmonitored load switch outputs.** This could occur as a result of improper configuration of the cabinet, improper address assignment for one or more AMU-214 units, improper address assignment for one or more SIU units, or improper programming of the ATC.

## 1.4 CMU-212 PROGRAMMING

The CMU-212 is individually configured using a removable nonvolatile memory device called a Datakey<sup>™</sup> (Datakey is a registered trademark of Datakey Electronics, Inc.). The Datakey replaces the mechanical jumper or diode based program card used in conventional signal monitors and provides an electronic method of programming the CMU-212. The Datakey contains a nonvolatile prom device that is read by the CMU-212. The Datakey itself is programmed by a separate programming device using a Personal Computer program such as the Eberle Design MonitorKey product. See the Eberle Design **MonitorKey Operations Manual** for further details.

The Datakey is interoperable with any CMU-212 meeting the requirements of the ASHTO/ITE/NEMA **Intelligent Transportation System (ITS) Standard Specification for Roadside Cabinets Version 01.02.17b**.

## 1.5 DETAILED CMU STATUS

### 1.5.1 ECcom Software Interface

The front panel display of the CMU-212 provides limited operational status. Detailed status is obtained through the front panel EIA-232 port (CMU-212) or optional Ethernet port (CMUip-212) using Eberle Design **ECcom** Signal Monitor Communications software running on a personal computer. The ECcom software provides access to real time monitor data such as current field signal status, field terminal voltages, cabinet control voltages, channel load current status, temperature, and fault status. Historical event logs and signal sequence logs are also provided. See the Eberle Design **ECcom Operations**



## **1.8 FAILED STATE ACTION (LFSA, LFSA-R, NFSA)**

When triggered by the detection of a fault condition that exists longer than the minimum defined period, the CMU-212 will enter the Failed State Action (fault) mode causing the OUTPUT relay to de-energize and the contacts on the OUTPUT NO pins to open. The cabinet assembly should be wired such that the opening of the OUTPUT NO relay contacts will cause an automatic switching of the field signal outputs from normal operation to flashing operation.

Only Unit Reset from the Reset Button or EXTERNAL RESET TEST input will reset the CMU-212 from a LATCHED FAILED STATE ACTION (LFSA). Only a Unit Reset from the Reset Button or EXTERNAL RESET TEST input or a CMU-212 Power Fail will reset a LATCHED RESETTABLE FAILED STATE ACTION (LFSA-R).

A NONLATCHED FAILED STATE ACTION (NFSA) will be reset if the fault conditions causing the NFSA have been removed. An NFSA will last for the programmed Minimum Flash time at a minimum.

Only one LFSA, LFSA-R or NFSA fault state will be set at any time.

### **1.8.1 Exit From FSA**

Prior to the CMU-212 transferring the OUTPUT NO contacts from the FSA state to the No Fault state, a transition period of 500 milliseconds will occur. During the transition period the OUTPUT NO contacts will be in the FSA state and the CMU-212 will set the Start-Up Flash Call bit in the Type 189 Frame to 1. At all other times the Start-Up Flash Call bit of the Type 189 Frame will be set to 0. This provides an early indication to the ATC that exit from the FSA state is occurring and the start-up phases should be set.

## Section 2 MONITOR FUNCTIONS

### 2.1 CABINET POWER SUPPLY MONITOR

The CMU-212 will sense the Cabinet +24VDC and +12VDC power supply sources. The CMU-212 will also sense the Cabinet +24VDC state in each Output Assembly as reported by each AMU. Voltages equal to or greater than +22 Vdc and +11 Vdc respectively will not cause a LFSA. Voltages at or less than +18 Vdc and +9 Vdc for 500ms or longer will cause a LFSA. If the sensed voltage is less than +22 Vdc or +11 VDC for 200 ms or less, the CMU-212 will not cause a LFSA. All other timing or voltage conditions may or may not cause LFSA. A +24VDC failure or +12VDC failure during the programmed Minimum Flash time or during a CMU-212 Power Failure will not cause a LFSA. The CMU-212 will report the value of the +24 VDC and +12 VDC power supply sources in the Type 189 response frame.

There is programming in the Datakey to disable +12 VDC power supply monitoring.

### 2.2 CONFLICTING CHANNELS MONITOR

For purpose of conflict determination, an active signal on either of the Green/Walk or Yellow inputs associated with any of the 32 channels will be considered as that channel being active. The Datakey will contain the permissive channel pair programming.

When any conflicting channels are detected as concurrently active for less than 200 milliseconds the CMU-212 will not cause a LFSA. When any conflicting channels are detected as concurrently active for 500 milliseconds or more, the CMU-212 will cause a LFSA. When any conflicting channels are detected as concurrently active for more than 200 milliseconds but less than 500 milliseconds, the CMU-212 may or may not cause a LFSA.

### 2.3 SERIAL BUS MONITOR

The CMU-212 communicates with both Serial Bus (SB) #1 and #3. In SB #1 the CMU-212 is a Secondary device, polled by the ATC Primary device. On SB #1, the CMU-212 will respond to the Serial Bus #1 Address defined by the ADDRESS 0 and ADDRESS 1 pins. On SB #3 the CMU-212 is the Primary device, polling each AMU-214 Secondary device.

#### 2.3.1 Serial Bus #1 Error

The CMU-212 will cause a FSA when a Type 61 or Type 67 Frame has not been received from the ATC for greater than 1000 milliseconds. The first and second failures in a 24-hour period will be a NFSA. The third failure in a 24-hour period will be a LFSA-R. If a CMU-212 Power Fail resets the LFSA-R, the SB #1 failure count will be reset to two, such that the next SB #1 timeout results in a LFSA-R.

A SB #1 timeout failure during the programmed Minimum Flash time or during a CMU-212 Power Failure will not cause a FSA. The SB #1 Timeout function will be disabled if the SB #1 DISABLE input is at a True (Low) state

#### 2.3.2 Serial Bus #3 Error

The CMU-212 will cause a FSA when a Type 129 or Type 130 Frame has not been received from each AMU for greater than 300 milliseconds. The first and second failures in a 24-hour period will be a NFSA. The third failure in a 24-hour period will be a LFSA-R. If a CMU-212 Power Fail resets the LFSA-R, the SB #3 timeout count will be reset to two, such that the next SB #3 timeout results in a LFSA-R.

A SB #3 timeout failure during the programmed Minimum Flash time or during a CMU-212 Power Failure will not cause a FSA.

## 2.4 TYPE 62 FSA MESSAGE

If the "N" bit is set in a Type 62 message, the CMU-212 will react by causing a NFSA. The NFSA will remain until the receipt of a Message 62 with the "N" bit cleared or until the CMU-212 is reset by a Unit Reset or CMU-212 Power Fail. The NFSA will last for the programmed Minimum Flash time at a minimum.

If the "L" bit is set in a Type 62 message, the CMU-212 will react by causing a LFSA.

## 2.5 LACK OF SIGNAL INPUTS MONITOR

The CMU-212 will detect the absence of a required signal voltage on all the inputs of a channel OR the absence of any required channel load current. For voltage purposes a required signal on the Green OR Yellow OR Red inputs associated with a channel will be considered as that channel being Voltage Active. For load current purposes a total channel load current above the programmed threshold for a channel will be considered as that channel being Current Active. When a channel is not Voltage Active OR Current Active for less than 700 milliseconds, the CMU-212 will not cause a LFSA. When a channel is not Voltage Active OR Current Active for greater than 1000 milliseconds, the CMU-212 will cause a LFSA. When a channel is not Voltage Active OR Current Active for more than 700 milliseconds but less than 1000 milliseconds, the CMU-212 may or may not cause a LFSA.

The Current Sense Unit (CSU) monitor function is hardwired to the maximum of 28 physical channels, thus Virtual Channels do not have CSU monitoring capability. The CSU monitor function must be disabled for any physical channel that has an input remapped to a Virtual Channel.

Lack of Signal Input monitoring will be disabled for all channels when the MC COIL STATUS input is not active. There is programming in the Datakey to disable Lack of Signal Input monitoring on a per channel basis.

Lack of Signal Input monitoring will also be disabled for any channel which has the DARK CHANNEL MAP bit set to "1" in the Datakey programming for the DARK CHANNEL MAP addressed by the DARK CHANNEL MAP SELECT bits in a Type 61 message.

## 2.6 MULTIPLE INPUT MONITOR

The CMU-212 will detect the presence of an active signal on two or more inputs of a channel. When the presence of an active signal on two or more inputs of a channel is detected for less than 200 milliseconds, the CMU-212 will not cause a LFSA. When the presence of an active signal on two or more inputs to a channel is detected for 450 milliseconds or more, the CMU-212 will cause a LFSA. When the presence of an active signal on two or more inputs to a channel is detected for more than 200 milliseconds but less than 450 milliseconds, the CMU-212 may or may not cause a LFSA.

Multiple Input monitoring may anticipate and prevent a possible conflicting signal display in the intersection in the event that a proceed signal on the current phase hangs up and is constantly detected as active. An open or no load condition (i.e., burned-out bulb) may be also detected as an active signal depending on the output impedance characteristics of the load switch (i.e. load switch leakage current), and may cause a Multiple Input Fault.

Multiple Input monitoring will be disabled when the MC COIL STATUS input is not active. There is programming in the Datakey to disable Multiple Indication monitoring on a color combination basis (G+Y, Y+R, G+R) for each channel.

## 2.7 YELLOW CLEARANCE MONITOR

The CMU-212 will verify that the Yellow Change interval is at least 2.7 +/-0.1 seconds. The Yellow Change interval consists of the duration of time in which the Yellow field signal input is active in a sequence from Green to Yellow to Red. When the minimum Yellow Change interval is not satisfied, the CMU-212 will cause a LFSA. The CMU-212 will report a Skipped Yellow Clearance when the Yellow

Change interval is less than 100 milliseconds. The CMU-212 will report a Short Yellow Clearance when the Yellow Change interval is less than 2.7 +/- 0.1 seconds and greater than 100 milliseconds.

Minimum Yellow Change interval monitoring will be disabled when the MC COIL STATUS input is not active. There is programming in the Datakey to disable Minimum Yellow Change interval monitoring on a per channel basis.

## **2.8 YELLOW PLUS RED CLEARANCE MONITOR**

The CMU-212 will verify that the Yellow Change plus Red Clearance interval between the end of an active Green/Walk signal and the beginning of the next conflicting Green/Walk signal is at least 2.7 +/- 0.1 seconds. When the minimum Yellow Change plus Red Clearance interval is not satisfied, the CMU-212 will cause a LFSA.

Minimum Yellow Change plus Red Clearance monitoring will be disabled when the MC COIL STATUS input is not active. There is programming in the Datakey to disable Minimum Yellow Change plus Red Clearance interval monitoring on a per channel basis.

## **2.9 LOCAL FLASH STATUS**

The CMU-212 will monitor the LF STATUS input. This input is used to indicate to the CMU-212 that the cabinet should be placed into NFSA as a result of the AUTO/FLASH switch being transferred to the FLASH position. When this signal is sensed as not active for greater than 500 milliseconds the CMU-212 will cause a NFSA. When this signal is sensed as not active for less than 200 milliseconds the CMU-212 will not cause a NFSA.

### **2.9.1 Local Flash Status Recovery**

Recovery from Local Flash Status NFSA will occur when this signal is sensed as active for greater than 500 milliseconds. When this signal is sensed as active for less than 200 milliseconds the CMU-212 will not cause recovery from Local Flash Status NFSA.

## **2.10 CIRCUIT BREAKER TRIP STATUS**

The CMU-212 will monitor the CB TRIP STATUS input. When one or more circuit breakers have tripped this input will go to the not active state. When this signal is sensed as not active for greater than 500 milliseconds the CMU-212 will cause a LFSA. When this signal is sensed as not active for less than 200 milliseconds the CMU-212 will not cause a LFSA.

## **2.11 FLASHER UNIT OUTPUT FAILED ALARM**

The CMU-212 will monitor the FLASHER 1-1, FLASHER 1-2, FLASHER 2-1, FLASHER 2-2 voltage states reported by each AMU-214. The AMU-214 reports the flasher state at the output assembly. Thus a failed state may indicate a malfunction of the connector system or flash voltage bus or flasher unit.

When a transition from the inactive state to the active state or a transition from the active state to the inactive state is absent for greater than 2500 milliseconds, the CMU-212 will set a status bit in the Type 189 frame. This alarm condition will not cause a FSA. It should cause the appropriate response in the ATC. This status is non-latching such that once a status bit has been set, the sensing of five valid transitions of the input will clear the status bit.

## **2.12 CMU POWER FAILURE**

The CMU-212 will monitor the AC+ RAW input and the NRESET and POWERDOWN cabinet control inputs to determine a CMU Power Failure response. The POWERDOWN signal in the False (low) state indicates loss of AC+ RAW in the ATC. A CMU Power Failure will be recognized when both the POWERDOWN and NRESET signals are False (low) for greater than 100 ms or the AC+ RAW voltage is less than 82 +/- 2 Vrms.

### **2.12.1 AC+ RAW Level Sense**

The CMU-212 will monitor the AC+ RAW input and AC+ RAW inputs reported by each AMU-214. When any AC+ RAW voltage is less than the AC Line Dropout voltage (section 5.1) for greater than AC Line Level Sense timing (section 5.2) the CMU-212 will cause a NFSA. Once NFSA has been set, the POWERDOWN and NRESET signals will not be monitored until all AC+ RAW voltages have exceeded the AC Line Restore voltage (section 5.1).

### **2.12.2 Power Interrupt**

The CMU-212 will disable monitoring of the +12VDC and +24VDC power supply inputs when either the POWERDOWN or NRESET input is False (low). When the POWERDOWN and NRESET signals are both False (low) the CMU-212 will cause a NFSA.

### **2.12.3 Power Recovery**

When the POWERDOWN input is True (high) and the NRESET signal goes from False (low) to True (high) the CMU-212 will begin timing the programmed Minimum Flash Interval. During the Minimum Flash Interval the CMU-212 will be in NFSA.

### **2.12.4 Power Up**

Following initial application of AC+ RAW voltage the CMU-212 will maintain a NFSA until the POWERDOWN input is True (high) and the NRESET signal goes from False (low) to True (high). The CMU-212 will then begin timing the programmed Minimum Flash Interval. During the Minimum Flash Interval the CMU will be in NFSA.

### **2.12.5 Minimum Flash Interval**

During the Minimum Flash Interval the CMU-212 will be in NFSA. The Minimum Flash Interval will be programmed in the Datakey between the limits of 6 seconds to 16 seconds with an incremental adjustment of 1 second. The CMU-212 will not set a FSA during the Minimum Flash Interval.

## **2.13 FIELD OUTPUT CHECK**

The Field Output Check is a continuous verification that the field signal output states set by the ATC are properly driven to the signal loads and correctly sensed by the AMU-214 and CMU-212. It is an enhanced function made possible by the Serial Bus #1 communications between the ATC and CMU-212. The CMU-212 will receive a Type 61 message from the ATC that contains an image of the controller output commands to the load switches. When a fault condition triggers the CMU-212, the Type 61 message information received while the fault condition was being timed will be used by the CMU-212 to determine whether the sensed field signal input status corresponded to the ATC output commands. This diagnostic information may then be used to isolate whether the fault condition was caused by an ATC malfunction or a failure in the load switch and/or field wiring.

The Field Output Check function is enabled for each channel input individually and provides two modes of operation, Field Check Mode and Field Check Status.

### **2.13.1 Field Check Mode**

The CMU-212 will compare the active states of the field signals with the states reported by the ATC in the Type 61 frame. When a mismatch is detected for less than 700 milliseconds the CMU-212 will not cause a LFSA. When a mismatch is detected for 1000 milliseconds or more, the CMU-212 will cause a LFSA. When a mismatch is detected for more than 700 milliseconds but less than 1000 milliseconds, the CMU-212 may or may not cause a LFSA.

The Field Check Mode is typically caused by a miss-wired or improperly configured cabinet. When the Field Check Mode is detected the FIELD CHECK front panel indicator will be illuminated solid.

Field Output Check monitoring will be disabled when the MC COIL STATUS input is not active. There is programming in the Datakey to disable Field Output Check monitoring on a channel input basis.

### **2.13.2 Field Check Status**

The CMU-212 will compare the active states of the field signals with the states reported by the CU in the Type 61 frame. When a mismatch is detected while a Conflict, Lack of Signal, or Multiple fault is timing, Field Check Status will be reported with the fault to indicate the faulty channel(s) and color(s).

If a Conflict, Lack of Signal, or Multiple fault has triggered the CMU-212 to the fault mode and the CMU-212 indicates that there is no Field Check Status, the ATC or ATC programming is the most likely cause. The lack of Field Check Status indicates the ATC drove the signals to an improper state. If a Conflict, Lack of Signal, or Multiple fault has triggered the CMU-212 to the fault mode and the CMU-212 indicates that there is Field Check Status, then cause of the malfunction can be isolated to the SIU, load switch, field wiring, or signal load.

When Field Check Status is detected the FIELD CHECK front panel indicator will be flash at a 2Hz rate.

Field Output Check monitoring will be disabled when the MC COIL STATUS input is not active. There is programming in the Datakey to disable Field Output Check monitoring on a channel input basis.

## **2.14 DIAGNOSTIC ERROR**

The CMU-212 is provided with a resident series of self-check diagnostic capabilities. When a Diagnostic fault is detected, a LFSA-R will be set and the DIAGNOSTIC indicator illuminated. Should a Diagnostic error occur, other fault indicators that may be concurrently displayed with the DIAGNOSTIC indicator may not be valid due to the nature of these hardware and/or firmware failures.

### **2.14.1 Ram Memory Diagnostic**

This test will verify that all RAM elements are operating correctly at power-up or following a Unit Reset.

### **2.14.2 Nonvolatile Memory Diagnostic**

This test will verify that the nonvolatile flash ROM and event log eeprom contain the proper data. The routine will perform a check on each ROM device and make a comparison with a check value. This test is performed at power-up and at a minimum rate of 1024 bytes per second during operation

### **2.14.3 Datakey Memory Diagnostic**

This test will verify whether the non-volatile Datakey contains valid data. The routine will perform a check on each nonvolatile memory element at power-up and whenever read and make a comparison with a 16 bit Frame Check Sequence (FCS) procedure defined in clause 4.6.2 of ISO/IEC 3309. Invalid data may result from corrupted Datakey contents, an invalid FCS calculation, invalid parameter values, or a Datakey Protocol Version incompatibility.

The Datakey not present will cause a LFSA and illuminate the DIAGNOSTIC indicator if the DOOR SWITCH FRONT input is sensed as not active (door closed). The DIAGNOSTIC indicator will flash at a rate of 2Hz if the Datakey is not present when the DOOR SWITCH FRONT input is sensed as active (door open).

### **2.14.4 Internal MPU Monitor**

The CMU-212 will monitor the operation of its microprocessor with an independent circuit. At a minimum, the monitoring circuit will receive logic state transitions at least once every 50 milliseconds from the microprocessor. When the logic state transition is not received for 500 milliseconds the monitor circuit will force a LFSA-R and illuminate the DIAGNOSTIC indicator.

## **2.15 RECURRENT PULSE DETECTION**

This error detection function supplements the normal Conflict, Multiple, and Lack of Signal monitoring algorithms for sensing faults that are intermittent or pulsing in nature. The RMS signal detection algorithm is designed to filter out short term transients commonly found on the electrical service and provide noise immunity against false signal detections. The Recurrent Pulse detection function is designed to respond to fault conditions that are intermittent in nature and do not meet the continuous

timing requirements of the normal detection algorithms, yet may still produce improper signal displays. These input conditions are differentiated by their longer time constant and fault response times.

The figure below shows a simple example of a recurrent Conflict fault. Channel 2 Green is detected active due to a malfunction of the load switch that caused the output to “flicker” On for 100 ms approximately every 200 ms. Because normal Conflict detection requires a continuous fault of at least 350 ms duration, this event could go undetected. The Recurrent Pulse detection algorithm will combine these pulses into one event and trigger a Conflict fault once the longer recurrent timing threshold is exceeded.

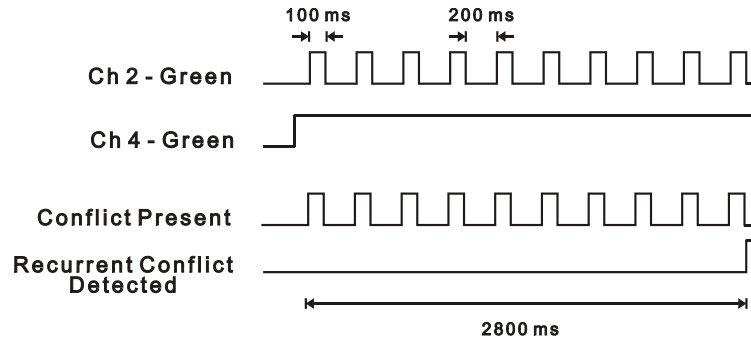

When triggered by a recurrent fault condition, the Signal Monitor will enter the fault mode, transfer the Output relay contacts to the Fault position, and illuminate the appropriate CONFLICT, MULTIPLE, or LACK OF SIGNAL indicator. The unit will remain in the fault mode until reset by the Reset button or the External Reset input. Fault response times will vary depending on the pulse width and frequency of the recurrent inputs, but will range from 1000 ms minimum to 10.4 seconds maximum. Recurrent Pulse detection can be disabled with the SEL1 option jumper, see Section 2.15.1.

### 2.15.1 Recurrent Pulse Detection Disable

The Recurrent Pulse Detection function can be disabled by soldering a 0-ohm jumper into position SEL1 on the CMU-212 printed circuit board. When the jumper is inserted, Recurrent Pulse Detection is disabled. When the jumper is removed, Recurrent Pulse Detection is enabled.

## Section 3 INPUT SIGNALS

### 3.1 FIELD SIGNAL INPUTS

A Green or Yellow signal input will be sensed active when it exceeds 25 Vrms and will not be sensed active when it is less than 15 Vrms. A Green or Yellow signal between 15 and 25 Vrms may or may not be sensed active. There is programming in the Datakey to disable the Yellow input for each physical channel.

A Red signal input will be sensed active when it exceeds 70 Vrms and will not be sensed active when it is less than 50 Vrms. A Red signal between 50 and 70 Vrms may or may not be sensed active.

### 3.2 LOAD SWITCH CURRENT

Load current is sensed by the AMU-214 based on total load current to all colors of a channel. Total load current is an indication that a signal load is present. Lack of adequate load current indicates no active load (i.e. burned out lamps) or an open field wire condition. Load current monitoring is used by the Lack of Signal monitoring function (see 2.5) to detect the loss of signal load while the load switch is in the On state.

A channel will be sensed active when the load current exceeds 105% of the Channel Current Sense Threshold programmed for that channel in the Datakey. A channel will not be sensed active when the load current is less than 95% of the Channel Current Sense Threshold programmed for that channel in the Datakey. A load current value between 95% and 105% of the Channel Current Sense Threshold may or may not be sensed active. This provides a hysteresis value of +/- 5% of the Channel Current Sense Threshold.

The Channel Current Sense Threshold should be programmed for each monitored channel based on the minimum signal load under all worst case conditions.

### 3.3 PDA CONTROL SIGNAL INPUTS

#### 3.3.1 Local Flash Status

The cabinet should be wired such that operation of the cabinet in AUTO mode will place AC+ on the LF STATUS pin. Operation of the cabinet in FLASH mode should be open circuit on this input. This input will be considered active when the input voltage exceeds 89 Vrms. This input will not be considered active when the input voltage is less than 70 Vrms. Signals between 89 Vrms and 70 Vrms may or may not be considered active. The CMU-212 will report the state of this input in the Type 189 frame. See section 2.9.

#### 3.3.2 Main Contactor (MC) Coil Status

The cabinet should be wired such that the MC COIL STATUS input is connected to the AC+ RAW side of the main contactor signal bus relay coil. An active signal on this input indicates the Signal Bus should be powering the load switches. This input will be considered active when the input voltage exceeds 89 Vrms. This input will not be considered active when the input voltage is less than 70 Vrms. Signals between 89 Vrms and 70 Vrms may or may not be considered active. The CMU-212 will report the state of this input in the Type 189 frame.

#### 3.3.3 Main Contactor (MC) Secondary Status

The cabinet should be wired such that the MC SECONDARY STATUS input will be connected to the output side of the main contactor signal bus relay. An active signal on this input indicates the Signal Bus is powering the load switches. This input will be considered active when the input voltage exceeds 89

Vrms. This input will not be considered active when the input voltage is less than 70 Vrms. Signals between 89 Vrms and 70 Vrms may or may not be considered active. The CMU-212 will report the state of this input in the Type 189 frame.

### 3.3.4 FTR Coil Drive Status

The cabinet should be wired such that the FTR COIL DRIVE STATUS input is connected to the FTR COIL DRIVE signal in the AC SIGNAL POWER BUS. An active signal on this input indicates the flash transfer relays are energized and the field signals are driven from the load switch outputs. This input will be considered active when the input voltage exceeds 89 Vrms. This input will not be considered active when the input voltage is less than 70 Vrms. Signals between 89 Vrms and 70 Vrms may or may not be considered active. The CMU-212 will report the state of this input in the Type 189 frame.

### 3.3.5 Circuit Breaker (CB) Trip Status

The cabinet should be wired such that the CB TRIP STATUS input will be connected to the Auxiliary Switch output of the circuit breaker unit. The active state of this input indicates that the circuit breaker unit is not in the tripped state. This input will be considered active when the input voltage exceeds 89 Vrms. This input will not be considered active when the input voltage is less than 70 Vrms. Signals between 89 Vrms and 70 Vrms may or may not be considered active. The CMU-212 will report the state of this input in the Type 189 frame.

### 3.3.6 Front / Rear Door Switch

The cabinet should be wired such that AC+ is applied to the DOOR SWITCH FRONT or DOOR SWITCH REAR inputs when the respective door is Open. These inputs will be considered active (door open) when the input voltage exceeds 89 Vrms. These inputs will not be considered active (door closed) when the input voltage is less than 70 Vrms. Signals between 89 Vrms and 70 Vrms may or may not be considered active. The CMU-212 will report the state of these inputs in the Type 189 frame.

The Datakey not present will cause a LFSA if the DOOR SWITCH FRONT input is sensed as not active (door closed). See section 2.14.3.

## 3.4 MONITOR INTERLOCK

The MONITOR INTERLOCK input is connected to VDC GROUND within the CMU-212. The cabinet should be wired such that the lack of VDC GROUND on this pin forces the cabinet to the flash mode. This prevents a cabinet from operating without a CMU-212 installed.

## 3.5 EXTERNAL TEST RESET INPUT

The EXTERNAL TEST RESET input is used to reset the CMU-212 from the FSA condition. When the EXTERNAL TEST RESET input is connected to VDC GROUND (True) all front panel indicators will be illuminated for 100 msec and the OUTPUT relay energized. Continuously activating the input will not affect CMU-212 operation.

The EXTERNAL TEST RESET input is intended for use in testing the CMU-212 and should not be connected in the cabinet.

## 3.6 SERIAL BUS #1 ADDRESS INPUTS

The Address Select input pins ADDRESS 0 and ADDRESS 1 define the Serial Bus #1 address of the CMU. The pins are left open for a logical False, and are connected to VDC GROUND for a logical True.

ADDRESS 1	ADDRESS 0	SB #1 ADDRESS
False	False	0x0F
False	True	0x10

ADDRESS 1	ADDRESS 0	SB #1 ADDRESS
True	False	0x11
True	True	0x12

The default address for the CMU is 0x0F. If multiple CMU units are not installed on Serial Bus #1 these inputs should be left in the False (open) state.

### 3.7 SERIAL BUS #1 DISABLE INPUT

The SERIAL BUS #1 DISABLE input is used to prevent a Serial Bus #1 Error when communications from the ATC is not active. When the SERIAL BUS #1 DISABLE input is connected to VDC GROUND (True) The CMU-212 will not communicate on Serial Bus #1 or set a FSA condition if communications from the ATC is not present. See section 2.3.1.

The SERIAL BUS #1 DISABLE input is intended for use in testing the CMU-212 and should not be connected in the cabinet.

### 3.8 PDA TEMPERATURE

The CMU-212 will measure the ambient temperature in the PDA and report this value in the Type 182 frame. This temperature indication may be used to analyze malfunctions that could be related to over heating or cold conditions.

## Section 4 FRONT PANEL DESCRIPTION

### 4.1 INDICATORS

#### 4.1.1 Power Indicator

A green POWER indicator will illuminate to indicate AC+ RAW voltage is proper. It will flash at a 2 Hz rate when the AC+ RAW input of the CMU or AMUs are less than the AC Line Dropout (see section 5.1). It will remain Off when the AC+ RAW voltage is less than 70 +/- 2 Vrms. See section 2.12.

#### 4.1.2 24VDC FAIL Indicator

A red 24VDC FAIL indicator will illuminate when the CMU-212 is in FSA as a result of a 24VDC cabinet power supply fault. See section 2.1.

#### 4.1.3 12VDC FAIL Indicator

A red 12VDC FAIL indicator will illuminate when the CMU-212 is in FSA as a result of a 12VDC cabinet power supply fault. The 12VDC FAIL indicator will pulse at a 2 Hz rate when the 12VDC monitor function is disabled. See section 2.1.

#### 4.1.4 CONFLICT Indicator

A red CONFLICT indicator will illuminate when the CMU-212 is in FSA as a result of a Conflicting Channels fault. See section 2.2.

#### 4.1.5 LACK OF SIGNAL Indicator

A red LACK OF SIGNAL indicator will illuminate when the CMU-212 is in FSA as a result of a Lack of Signal Inputs fault. See section 2.5.

#### 4.1.6 MULTIPLE Indicator

A red MULTIPLE indicator will illuminate when the CMU-212 is in FSA as a result of a Multiple Inputs fault. See section 2.6.

#### 4.1.7 CU / LOCAL FLASH Indicator

A red CU / LOCAL FLASH indicator will illuminate when the CMU-212 is in FSA as a result of a Type 62 command from the ATC (see section 2.4), the LOCAL FLASH STATUS input is inactive (see section 2.9), or CB TRIP STATUS is inactive (see section 2.10).

#### 4.1.8 CLEARANCE Indicator

A red CLEARANCE indicator will illuminate when the CMU-212 is in FSA as a result of a Yellow Clearance or Yellow Plus Red Clearance fault. See section 2.7 and 2.8.

#### 4.1.9 FIELD CHECK Indicator

A red FIELD CHECK indicator will illuminate when the CMU-212 is in FSA as a result of a Field Check Mode fault. The indicator will flash at a 2Hz rate when the CMU-212 is in FSA with Field Check Status as a result of Conflict, Lack of Signal, or Multiple fault. See section 2.13.

#### 4.1.10 SB #1 ERROR Indicator

A red SB #1 ERROR indicator will illuminate when the CMU-212 is in FSA as a result of a Serial Bus #1 fault. See section 2.3.1. The SB #1 ERROR indicator will pulse at a 2 Hz rate when the SERIAL BUS #1 DISABLE input is True. See section 3.7.

#### **4.1.11 SB #3 ERROR Indicator**

A red SB #3 ERROR indicator will illuminate when the CMU-212 is in FSA as a result of a Serial Bus #3 fault. See section 2.3.2.

#### **4.1.12 DIAGNOSTIC Indicator**

A red DIAGNOSTIC indicator will illuminate when the CMU-212 is in FSA as a result of a Diagnostic fault. See section 2.14.

The DIAGNOSTIC indicator will flash at a 4 Hz rate if the Datakey is not present and a FSA state does not exist. See section 2.14.3.

#### **4.1.13 SB #1 RX Indicator**

A yellow SB #1 RX indicator will pulse On each time the CMU-212 correctly receives a frame on Serial Bus #1.

#### **4.1.14 SB #3 RX Indicator**

A yellow SB #3 RX indicator will pulse On each time the CMU-212 correctly receives a frame on Serial Bus #3.

### **4.2 TERMINAL PORT**

An EIA-232-E Data Terminal Equipment (DTE) interface is provided for interconnecting to a personal computer using the EDI ECcom Signal Monitor Communications software package. See the Eberle Design *ECcom Operations Manual* for further details. This port is electrically isolated from the main CMU-212 power supply and AC+ Neutral.

### **4.3 RESET BUTTON**

Depressing the RESET button resets the CMU-212 from the FSA condition after it has been triggered by a fault. When the RESET button is depressed all front panel indicators will be illuminated for 500 msec and the OUTPUT relay energized. Continuously depressing the Reset button will not affect CMU-212 operation.

### **4.4 DATAKEY**

The front panel mounted Keycepticle<sup>™</sup> is used to receive the Datakey serial memory device. To install a Datakey, insert the key and rotate clockwise 90 degrees to the vertical orientation. When a Datakey is installed while the power is applied to the CMU-212, the CMU-212 will load and verify the parameters and begin using the new configuration immediately.

When a Datakey is removed while the power is applied to the CMU-212, the CMU-212 will continue to use the parameters from the removed Datakey until Reset is applied, a new Datakey is installed, or a power-up cycle occurs.

If a CMU-212 is Reset or powered-up with the Front Door in the open position without a Datakey installed or with an invalid Datakey, the CMU-212 will assume a default Datakey configuration according to the Datakey Protocol Version.

## Section 5 SPECIFICATIONS

### 5.1 ELECTRICAL

#### Power Requirements

Operating Line Voltage .....	75 to 135 Vac
Operating Line Frequency .....	60 ± 3 Hz
Power Consumption .....	10 Watts Maximum

#### AC Voltage Monitors

Red Field Signals	
Active.....	greater than 70 Vrms
Not Active .....	less than 50 Vrms
Yellow Field Signals	
Active.....	greater than 25 Vrms
Not Active .....	less than 15 Vrms
Green Field Signals	
Active.....	greater than 25 Vrms
Not Active .....	less than 15 Vrms

Local Flash Status, MC Coil Status, MC Secondary Status, FTR Coil Drive, CB Trip Status, Front / Rear Door Switch

Active.....	greater than 89 Vrms
Not Active .....	less than 70 Vrms

#### Power Fail Monitor

AC Line Restore .....	greater than 87 ± 2 Vrms
AC Line Dropout.....	less than 82 ± 2 Vrms

#### DC Voltage Monitors

+24 Volt Monitor	
Active.....	greater than 22 Vdc
Not Active .....	less than 18 Vdc
+12 Volt Monitor	
Active.....	greater than 11 Vdc
Not Active .....	less than 9 Vdc

#### Logic Inputs

External Test Reset, Serial Bus #1 Disable, Address 0, Address 1

Not Active (False) .....	greater than 16 Vdc
Active (True) .....	less than 8 Vdc

#### CMU Temperature

Accuracy .....	± 6 °C
----------------	--------

### 5.2 TIMING

Cabinet Power Supplies

Fault .....	greater than 500 ms
No Fault.....	less than 200 ms
Typical.....	350 ms

Conflict

CMU-212 Cabinet Monitor Unit  
Operations Manual

---

Fault .....	greater than 500 ms
No Fault.....	less than 200 ms
Typical.....	350 ms
Serial Bus #1 Error	
Fault .....	greater than 1000 ms
Serial Bus #3 Error	
Fault .....	greater than 300 ms
Multiple	
Fault .....	greater than 450 ms
No Fault.....	less than 200 ms
Typical.....	350 ms
Lack of Signal Inputs	
Fault .....	greater than 1000 ms
No Fault.....	less than 700 ms
Typical.....	850 ms
Yellow Clearance	
Fault .....	less than 2600 ms
No Fault.....	greater than 2800 ms
Typical.....	2700 ms
Yellow Plus Red Clearance	
Fault .....	less than 2600 ms
No Fault.....	greater than 2800 ms
Typical.....	2700 ms
Field Check	
Fault .....	greater than 1000 ms
No Fault.....	less than 700 ms
Typical.....	850 ms
Local Flash Status, Circuit Breaker Trip	
Fault .....	greater than 450 ms
No Fault.....	less than 200 ms
Typical.....	350 ms
AC Line Level Sense	
Fault .....	greater than 750 ms
No Fault.....	less than 550 ms
Typical.....	650 ms
NRESET, POWERDOWN	
Active.....	greater than 120 ms
Not Active .....	less than 80 ms
Typical.....	100 ms

**5.3 MECHANICAL**

Height.....	4.166 inches
Width.....	2.200 inches
Depth (front panel to rear edge of DIN connector).....	7.682 inches

**5.4 ENVIRONMENTAL**

Storage Temperature Range .....	-45 to +85 °C
Operating Temperature Range .....	-34 to +74 °C
Humidity (non-condensing) .....	0 to 95% Relative

## Section 6 CONNECTOR ASSIGNMENTS

### 6.1 MAIN DIN CONNECTOR

The CMU-212 main connector is a two row DIN 4161264 Header Type:

Pin #	Function	Pin #	Function
A1	+24VDC Monitor	B1	Reserved
A2	+12VDC Monitor	B2	External Test Reset
A3	VDC Ground	B3	Serial Bus #1 Disable
A4	Monitor Interlock	B4	Reserved
A5	Address 0	B5	Address 1
A6	Reserved	B6	Reserved
A7	SB1 TxData +	B7	SB1 TxData -
A8	SB1 RxData +	B8	SB1 RxData -
A9	SB1 TxClock +	B9	SB1 TxClock -
A10	SB1 RxClock +	B10	SB1 RxClock -
A11	Reserved	B11	Reserved
A12	Reserved	B12	Reserved
A13	Reserved	B13	Reserved
A14	Reserved	B14	Reserved
A15	Line Sync +	B15	Line Sync -
A16	Nreset +	B16	Nreset -
A17	PowerDown +	B17	PowerDown -
A18	SB3 TxData +	B18	SB3 TxData -
A19	SB3 RxData +	B19	SB3 RxData -
A20	SB3 Clock+	B20	SB3 Clock-
A21	LF Status	B21	LF Status
A22	Output Relay NO	B22	Output Relay NO
A23	CB Trip Status	B23	Reserved
A24	MC Coil Status	B24	Reserved
A25	MC Secondary Status	B25	Reserved
A26	FTR Coil Drive Status	B26	Reserved
A27	Door Switch Front	B27	Reserved
A28	Door Switch Rear	B28	Reserved
A29	Reserved	B29	Reserved
A30	Reserved	B30	AC+ RAW
A31	Equipment Ground	B31	Reserved
A32	Reserved	B32	AC- Neutral

Note: Output Relay NO is open during FSA (de-energized).

### 6.2 EIA-232 CONNECTOR

The front panel EIA-232 connector is a 9 pin metal shell "DB9S" female subminiature type connector. Because the port is configured as a DTE device, a null modem cable is required to connect directly to a personal computer COMM port.

Pin #	Function	I/O
1	Reserved	-
2	Receive data	I
3	Transmit Data	O
4	Reserved	-
5	Signal Ground	-
6	Reserved	-
7	Reserved	-
8	Reserved	-
9	Reserved	-

### 6.3 CMUIP-212 ETHERNET LAN PORT

The CMUip-212 Ethernet port must be configured with specific network parameters such as an IP address. The network port parameters are set or changed using the EDI *ECcom™* Signal Monitor Communications software. See the "**EDI CMUip-212 Ethernet Quick Start Manual**" (pn 888-0212-104) for details.

#### 6.3.1 Ethernet LAN Cable

The LAN cable required is a typical Cat-5 network cable using the 8 pin RJ-45 connector. If the connection is from the monitor to a switch or hub, a standard LAN cable is needed. If the connection is from the monitor directly to a network adaptor (PC), a cross-over or patch cable is needed.